

The best-selling Acorn magazine in the world

ACORN USER

Essential for all users of 32-bit RISC OS computers

Art Gallery

We showcase the best of Acorn art

Acorn's future plans

Massive storage devices

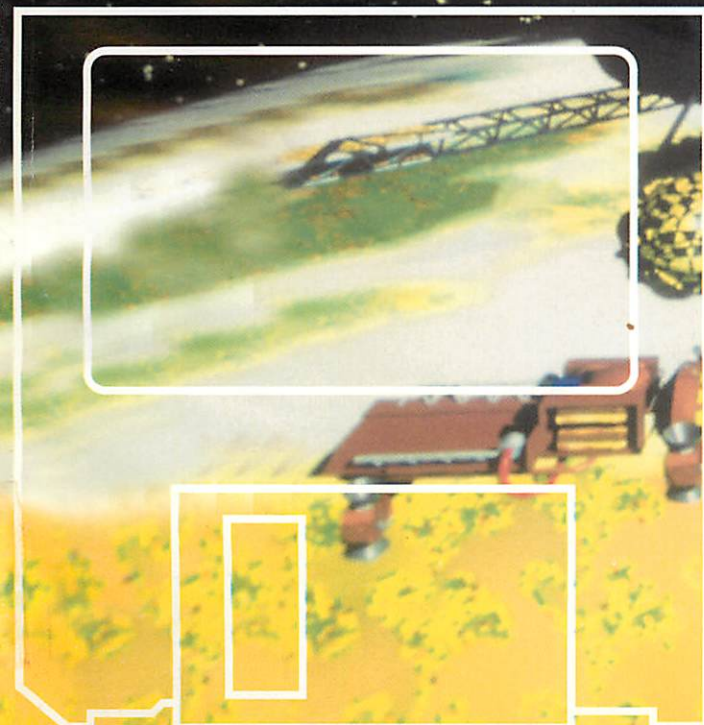

MARCH 1995 Issue 153 £2.95
03>



9 770263 745031

IMPRESSION Style

Impression Style is the newest word processor member of the Impression family, and the most comprehensive and powerful version so far released. Over the last few years Impression has become the most successful 32-bit Acorn software application and while Impression's DTP capabilities have been renowned, the fact is that most users use it as their day to day word processor. Impression Style is a major update, with special attention paid towards improving the word processing abilities still further, and making it even easier to use than before. So, for example, it now includes automatic paragraph numbering and

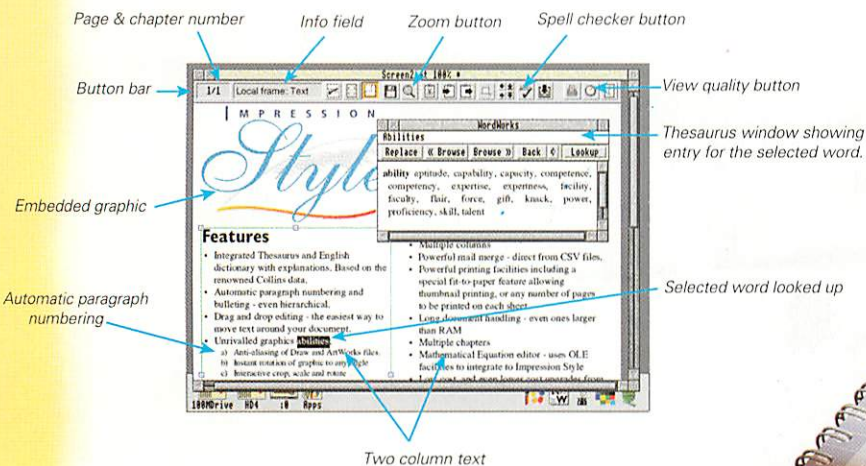

two sorts of on-line help amongst dozens of other improvements.

For those with technical writing needs it includes a mathematical equation editing utility and table building utility. For writers it includes what Archimedes World called "the superb WordWorks dictionary and thesaurus package." Other features that help make Impression Style a better text processor include automatic abbreviation expansion - one of the greatest time saving features available, drag and drop editing, an optional, configurable tool bar, along with firm favourites such as spell check as you type.

In a *modern* world of computer software we have *created* a package to leave you with a lasting *impression*



Archimedes World summed it up by calling it "a document processor of immeasurable power and sophistication."

And for those who need complete control over the page layout and appearance, Archimedes World and Acorn User magazines both had exactly the same conclusions - "Style itself is currently the best DTP package available."

"Importing foreign formats is one thing Style handles better than any other package I have encountered."

"The manuals are brilliant and offer full details on the use of the software. In fact, these manuals are so good, it seems unlikely that there will be much need for supplemental books from third party publishers."

"At the end of the day, Impression Style is a superb product for the relatively small asking price."

Archimedes World

"Impression Style represents ridiculous value for money."

Acorn User

"There is no other product on the Acorn platform to touch this, whether at the £100 asking price point or at £500. Every writer should own a copy."

Archimedes World

If you use your computer for word processing, then shouldn't you make sure that you use the best tools available?

Impression Style upgrade options

Upgrade from	Cost (ex VAT)	Total cost inc p&p and VAT
Impression Junior	£49.00+VAT	£57.58
Impression II	£49.00+VAT	£57.58
Other word processors†	£70.00+VAT	£82.25

†Other word processors include: Pipedream, Wordz, Ovation, First Word Plus, TechWriter, EasyWriter, StarWrite and Acorn Advance. To upgrade simply return your key / master / No1 disc with payment to Computer Concepts.

Impression Style RRP £99 + VAT (£116.32 inc)

Refer to table for special upgrade offers.

2Mbytes RAM recommended

Low cost educational site licences available.

Full specification available on request.



Computer Concepts Ltd

GADDESSEN PLACE, HEMEL HEMPSTEAD, HERTS HP2 6EX.

TEL: 0442 63933 FAX: 0442 231632

EMAIL: Info@CConcepts.co.uk

CONTENTS

Editor's letter

Mac and Amiga users always harp on about the superb graphics they can create on their machines, but take a look at the Acorn User Art Gallery on page 36 and you'll see that Acorn users are just as talented when it comes to computer art. Some of the artwork was even prepared on a 2Mb A3010 machine, so even if you don't own a 24Mb Risc PC, you can express your artistic side.

The other side of the coin is technology, and if you're interested in what Acorn thinks will happen to its technology over the next few years, take a look at 'TAOS beckons' on page 42. Our roving reporter discovered a thing or two about Acorn's plans that perhaps we shouldn't have found out...

Mark Moxon, Editor

Editor Mark Moxon

Deputy Editor David Matthewman

Production Editor Judith Chapman

Art Editor Alan Jones

Contributing editors

Ian Burley (News) Steve Atherton (Games)

Jack Kreindler (Graphics) David Dade

(Comms) Paul Wheatley (Public Domain)

Geoff Preston (Education) Steve Powell

(DTP) Alex Singleton (Business)

Advertisement Manager Emma Barr

Advertisement Sales Executive Lisa-Jo Oliver

Ad Production Wendy Binnersley

Ad Typesetting Alan Capper, Eddie Burke

Marketing Manager Lucy Oliver

Production Manager Sandra Childs

Commercial Director Denise Wright

Circulation Director David Wren

Distribution COMAG (01895) 444055

Subscriptions Database Direct 0151-357 1275

Managing Director Ian Bloomfield

Cover Dave Wilcox

Member of the Audit Bureau of Circulation
Acorn User is an independent publication and Acorn is not responsible for any of the articles in this issue or for any of the opinions expressed



Published by IDG Media Ltd,
Media House, Adlington Park,
Macclesfield SK10 4NP

e-mail mark@acornusr.demon.co.uk

Tel: (01625) 878888 Fax: (01625) 850652

Printed by Duncan Web Offset, Maidstone

13 issue subscription rate: £37.99 (UK),
£53.99 (EU), £68.99 (World)

1995 IDG Media Ltd.

No material may be reproduced in whole or in part without written permission. While every care is taken, the publishers cannot be held legally responsible for any errors in articles, listings or advertisements

REGULARS

9

News

Acorn Computing magazine to close

17

Graphics

Textured text backgrounds

19

Comms

ANT Internet suite

21

DTP

Virtual memory

23

Public Domain

Getting started in the Public Domain

25

Business

Fireworkz Professional

27

Education

The latest educational software

29

Portables

Pocket-sized Public Domain software

31

Cover disc

Wavelength demo and much more

59

Game show

Trendy games boxes

64

Letters

You have your say

80

Next Month

Free cover-mounted CD-ROM

82

Free Ads

Bargain hunters' paradise

84

Back issues

104

The subscribers' pages

A new offer for subscribers

106

The Moxon interview

Bill and Dave's excellent adventure

HANDS ON

86

C for yourself

Passing arguments to functions

89

Questions and answers

Your problems solved

93

Acorn customer hotline

Exclusive advice from Acorn

99

*INFO

More off-beat programs



REVIEWS

50

Cuckoo in the nest?

Acorn's long-awaited Risc PC 486 card

53

A good judge of character

Sleuth 2 OCR from Beebug

60

Games reviews

Face to Face and Sally & Wally

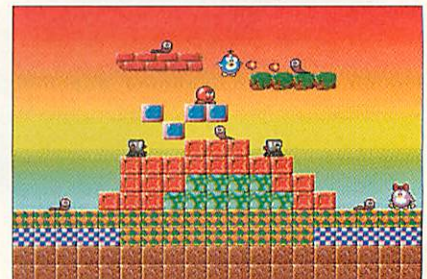

67

In brief

Six small reviews

75

Taking the tablets

Graphics tablets for budding artists

FEATURES

36

Thoroughly modern masters
The Acorn User art gallery



42

TAOS beckons
Acorn's vision of its future

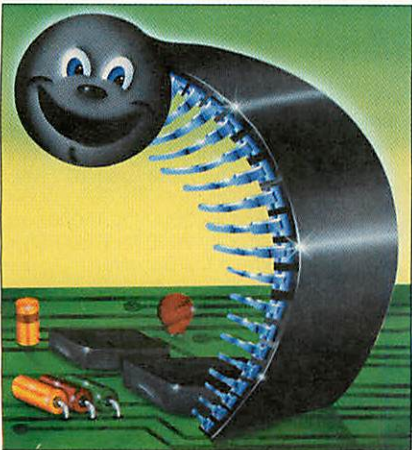

46

A surfeit of data
Very large storage devices

55

Spring celebrities
Stars of the spring show

71

Soundtrackers for the uninitiated
Creating the best tunes around

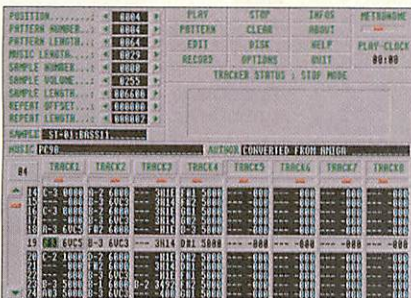

77

Prospecting for parents
Enhancing parents' open days

31

On the cover disc:
demo of Wavelength,
the hottest shoot-
'em-around

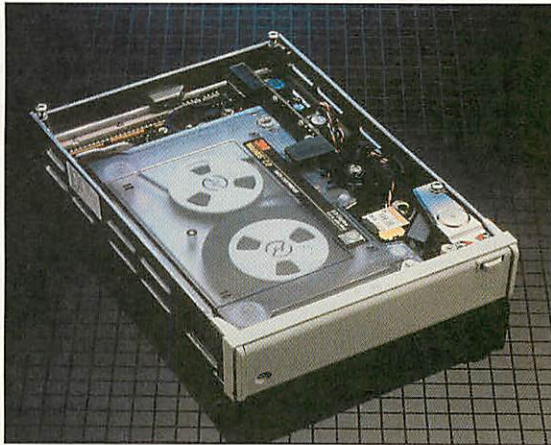

46

How to store
very, very
large files

50

Acorn's 486 PC
on a card for
the Risc PC:
how well does
it work?

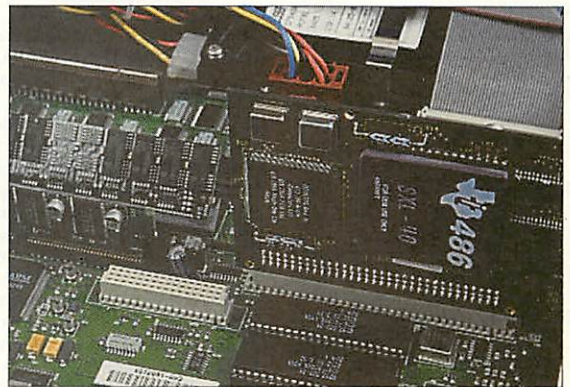

106

Meet the men
behind Sherston
Software



**NEXT
ISSUE
ON SALE
27 MARCH**



Software

!Draw_Help, age 13+ SHER V0£16
 10 out of 10 Dinosaurs 100U £18
 10 out of 10 Driving Test 100U £18
 10 out of 10 Early Essentials, age 6-100U £18
 10 out of 10 English, age 6-16 100U £18
 10 out of 10 French, age 6-16 100U £18
 10 out of 10 Junior Essentials, age 5-11 100U £18
 10 out of 10 Maths Algebra, age 6-16 100U £18
 10 out of 10 Maths Number, age 6-16 100U £18
 10 out of 10 Maths Statistics, age 6-16 100U £18
 10 out of 10 Spelling 100U £18
 Access for A3000 ACOR £138
 Access for Risc PC 600 ACOR £118
 Advance ACOR £88
 Advance primary site licence ACOR £181
 Advance secondary site licence ACOR £440
 Advance User Guide ACOR V0£11
 Advantage, KS2,3 LONG £46
 Air Supremacy SUPE £18
 All New Talking Animated Alphabet, age 3-6 SHER £27
 Amazing Maths, KS1-4 CAMS £19
 Ancestry, KS3,4 MINE £147
 Apollonius PDT OAKS £240
 AppleFS OREG £48
 ArcFax PILL £28
 ArcFS 2 VT10 £20
 Archimedes Game Maker's Manual SIGM V0£15
 Arcturus OREG £19
 Arcventure I ... The Romans, age 8-12 SHER £28
 Arcventure II ... The Egyptians, age 8-10 SHER £28
 Arcventure III ... The Vikings, age 7-11 SHER £28
 Armlock DIGS £33
 ArtWorks COMC £119
 ArtWorks CD (includes Clip-Art CD 1) COMC £139
 ArtWorks Made Easy DABS V0£15
 AudioWorks COMC £45
 Basic Wimp Programming DABS V0£15
 BBC Basic Reference Manual ACOR V0£22
 Beginner's Guide to Wimp Programming on the Archimedes SIGM V0£13
 Betsi, age 7-12 4MAT £32
 Birds of War (not Risc PC) FOUR £24
 Bitfolio Cartoon Graphics LOOK £17
 Bitfolio Clip Art Library CD LONG £47
 Black Angel FOUR £24
 Blinds QUAN £24
 Bodywise, age 9-14 (not Risc PC) SHER £42
 Break 147 & Superpool FOUR £24
 Burn 'Out OREG £19
 C (new edition) DABS V0£16
 CADet, KS3,4 MINE £99
 Cambridge Pascal OAKS £63
 Cannon Fodder KRIS £19
 CardShop CLAR £19
 Chaos Engine RENE £19
 Chartwell BEEB £23
 Chatter 4MAT £30
 ChessII PILL £14
 Chocks Away Compendium (not Risc PC) FOUR £25
 Chuck Rock (not Risc PC) KRIS £9
 Classcardz for Resultz COLT £20
 Classcardz for Wordz COLT £20

Selected prices 9th February 1995

Clip-Art CD 1 COMC £18
 ColourFun SMAR £12
 Complete Animator IOTA £95
 Compression COMC £31
 Crystal Maze, age 10+ SHER £28
 Crystal Rain Forest, age 8-11 SHER £38
 Cyber Chess FOUR £24
 Darryl the Dragon, KS1,2 4MAT £18
 DataPower IOTA £123
 Demon's Lair FOUR £18
 Design Processor OAKS £1150
 Desktop C ACOR £117
 Desktop Folio, KS1-4 ESMO £57
 Desktop Thesaurus BEEB £17
 Dinosaur Discovery, KS2 4MAT £25
 Disc Rescue LOOK £28
 Draw Print & Plot OAKS £28
 DrawBender ICSO £10
 Dune II ECLI £27
 Dungeon FOUR £24
 E-Type 2 FOUR £25
 E-Type Compendium FOUR £18
 Easy C (not Risc PC) BEEB £55
 EasyFont 3 FABI £27
 Eidoscope COMC £157
 Enter the Realm (not Risc PC) FOUR £18
 Eureka 3, KS2,3 LONG £83
 Event EXPL £21
 Eye for Spelling, KS1,2 ESMO £31
 Find It! APPI £34
 Fireworkz COLT £89
 First Logo, KS1,2 LONG £21
 First Page, KS2-4 LONG £42
 First Steps in Programming Acorn RISC OS Computers SIGM V0£15
 First Words with Smudge, age 4+ STOR £20
 Flashback, 1.6 Mb disc USGO £21
 Flashback, 800 kb discs USGO £21
 Flossy the Frog, KS1 (not Risc PC) 4MAT £23
 Flossy the Frog Art Disc 4MAT £10
 Font Directory LOOK £28
 Fantasy ICSO £15
 Fantasy / DrawBender / Placard ICSO £30
 FontFX DATS £10
 Formulix COMC £64
 Freddy Teddy TOPO £14
 Freddy Teddy: Balloons & The Zoo TOPO £20
 Freddy Teddy: The Playground TOPO £23
 Freddy Teddy: The Puddle & The Wardrobe TOPO £18
 Freddy Teddy's Adventure TOPO £14
 Fun School 3, age 5-7 EURO £18
 Fun School 4, age 5-7 EURO £18
 Genesis Professional OAKS £112
 Genesis Project OAKS £47
 Gods (not Risc PC) KRIS £9
 Goldilocks OAKS £38
 Gothic & Medieval Fonts and Decoration Pack 1 DATF £29
 Gothic & Medieval Fonts and Decoration Pack 2 DATF £32
 Granny's Garden 4MAT £23
 Graphics Loaders COMC £36
 GridPro (not Risc PC) 4MAT £35
 Hard Disc Companion II BEEB £42
 Hatchback 4MAT £32
 Hearsay II BEEB £59
 HeroQuest KRIS £20
 Home Accounts MINE £27
 House of Numbers CHAL £20
 Illusionist CLAR £40
 Image Animator IOTA £46
 Image Outliner IOTA £46
 ImageBank Picture Compression Library IRLA £26
 ImageFS ALTE £29
 ImageMaster PILL £24
 Impression Publisher COMC £122
 Impression Publisher network licence COMC £645
 Impression Publisher site licence COMC £535

Impression Publisher Plus COMC £259
 Impression Publisher Plus as upgrade from Impression Publisher COMC £125
 Impression Publisher Plus network licence COMC £925
 Impression Publisher Plus site licence COMC £775
 Impression Style COMC £76
 Impression Style site licence COMC £435
 Investigator III VT10 £42
 James Pond (not Risc PC) KRIS £9
 James Pond 2 + (not Risc PC) GAME £20
 JPEG & PhotoCD Loaders COMC £38
 Junior Database, KS1-3 IOTA £45
 Junior Insight, KS2,3 LONG £43
 Junior PinPoint, KS1,2 LONG £25
 Kid Pix, KS1,2 ESMO £34
 Knowledge Organiser 2 CLAR £63
 Landmarks - full range, KS2,3 LONG £24
 Landmarks Datafile - full range, KS2,3 LONG £24
 Lemmings KRIS £17
 Lemmings & Oh No! More Lemmings (Risc PC only) KRIS £23
 Lemmings II (Tribes) KRIS £20
 Logo, KS1-4 LONG £55
 Lotus Turbo Challenge 2 (not Risc PC) KRIS £18

NO CHARGE FOR CREDIT CARDS

MacFS COMC £76
 MacFS Light COMC £45
 Magic Pockets (not Risc PC) RENE £18
 Magpie LONG £50
 Manchester United Europe (not Risc PC) KRIS £9
 Masterfile III BEEB £43
 Maths Circus 4MAT £25
 Maths Odyssey COMT £40
 Monotype Fonts (Pack 1) LOOK £76
 Morphheus OREG £35
 Naughty Stories Volume 1 (set of 6), age 5-7 (not Risc PC) SHER £44
 Naughty Stories Volume 2 (set of 6), age 5-7 (not Risc PC) SHER £44
 NightSky CLAR £63
 Noddy's Playtime (not Risc PC) JUMP £18
 Notate, KS2-4+ LONG £49
 Oak PCB II OAKS £66
 Occasion EXPL £58
 Occasion network licence EXPL £118
 Oh No! More Lemmings (requires Lemmings) KRIS £15
 Ovation BEEB £68
 Oxford Reading Tree Stage 2 More Talking Stories A, age 5-7 SHER £37
 Oxford Reading Tree Stage 2 Talking Stories, age 5-7 SHER £37
 Oxford Reading Tree Stage 3 Talking Stories, age 5-7 SHER £37
 PC Emulator 1.8 ACOR £92
 PenDown, KS1-3 LONG £45
 PenDown Plus, KS2-4 LONG £67
 Personal Accounts V3 APRI £38
 Photobase Decades: The 1920s LONG £47
 Photobase Decades: The 1930s LONG £47
 Photobase Decades: The 1940s LONG £47
 Photobase Decades: The 1950s LONG £47
 Photobase Decades: The 1960s LONG £47
 Photobase: Landscapes LONG £47
 Photodesk SPAC £157
 PhotoTouch OREG £63
 PicturePoint, KS1,2 LONG £28
 PinPoint Datafile 1851 Census, KS3,4 LONG £14
 PinPoint 2, KS3,4 LONG £79
 PipeDream 4 COLT £85
 Placard ICSO £10
 Playdays, age 3-8 GAME £20
 Plot CLAR £63
 PrimeSolver, KS1-4 MINE £74

ProArtisan 24 CLAR £125
 ProCAD, KS4 MINE £450
 Programming in ANSI Standard C on the Archimedes SIGM V0£15
 Prophet (requires 2 Mb) APRI £145
 PublishArt, ArtWorks Format SMAR £25
 PublishArt, Draw Format SMAR £25
 QuickKey ICSO £10
 Rainbow, KS1,2 LONG £18
 Recordz COLT £97
 Render Bender 2 (not Risc PC) CLAR £40
 Rephorm OAKS £45
 Repro OAKS £46
 Resultz COLT £75
 Revelation ImagePro 24 bit, KS2-4 LONG £48
 Rhapsody 3 CLAR £74
 RISC OS 3 Applications Upgrade ACOR £10
 RISC OS 3 First Steps DABS V0£15
 RISC OS 3 Programmer's Reference Manual ACOR V0£99
 Rosie and Jim: Duck loses his Quack, age 4-6 SHER £10
 Rosie and Jim: Jim gets the Sneezes, age 4-6 SHER £10
 Sally and Wally OREG £19
 Saloon Cars Deluxe (not Risc PC) FOUR £24
 S-Base 2 Developer LONG £98
 S-Base 2 Personal LONG £48
 Schema 2 CLAR £95
 Score Draw CLAR £44
 Scrabble USGO £20
 Sensible Soccer (not Risc PC) RENE £19
 Serenade CLAR £75
 ShapeFX DATS £10
 Sibelius 6 SIBE £149
 Sibelius 6 primary site licence SIBE £299
 Sibelius 6 secondary site licence SIBE £599
 Sibelius 6 SIBE £789
 Sibelius 7 SIBE £789
 Sibelius 7 education and amateur price SIBE £464
 Sibelius 7 site licence SIBE £1450
 Sim City KRIS £22
 Sim City 2000 for A5000 KRIS £31
 Sim City 2000 for Risc PC KRIS £31
 Simon the Sorcerer GAME £31
 Sleuth BEEB £50
 Sleuth 2 BEEB £93
 Smart Borders +, ArtWorks Format SMAR £12
 Smart Borders +, Draw Format SMAR £12
 Smart Borders 2 SMAR £12
 Smart Resources 2, ArtWorks Format SMAR £12
 Smart Resources 2, Draw Format SMAR £12
 Smudge the Spaniel, age 4-8 STOR £19
 Somerset Talking Computer Project Learning Materials LONG V0£29
 Space City, age 7-9 SHER £26
 SparkFS PILL £20
 Special ICSO £10
 Speedball II KRIS £18
 Squirrel 2 DIGS £120
 Star Fighter 3000 FEDN £23
 Stunt Racer 2000 (not Risc PC) FOUR £24
 Talking Clocks TOPO £32
 Talking PenDown, KS1-3 LONG £53
 Titler CLAR £79
 Topographer CLAR £59
 Touch Type IOTA £38
 Trace PILL £9
 TurboDriver Canon COMC £39
 TurboDriver Epson Stylus 800 COMC £39
 TurboDriver HP COMC £39
 TurboDriver & LaserDirect Spooler COMC £144
 Twain Canon IX incl Scan-Light Professional PILL £16
 TWO (Task and Window Organiser) ICSO £10
 VersaTile OAKS £42
 Virtual Golf (not Risc PC) FOUR £23
 WinLogo, KS1-4 LONG £68
 Wolfenstein 3D POWE £23
 WorraCad OAKS £65

POSTAGE IS FREE FOR PREPAID SALES IN THE UK

Risc PC 600

Risc PC 600 2M HD210 14" Monitor	ACOR £1245
Risc PC 600 2M HD210 17" Monitor	ACOR £1645
Risc PC 600 2M HD210 Early Years 14" Monitor	ACOR £1269
Risc PC 600 2M HD210 Early Years 17" Monitor	ACOR £1669
Risc PC 600 2M HD210 Learning Curve 14" Monitor	ACOR £1269
Risc PC 600 2M HD210 Learning Curve 17" Monitor	ACOR £1669
Risc PC 600 5M HD210 14" Monitor	ACOR £1320
Risc PC 600 5M HD210 17" Monitor	ACOR £1720
Risc PC 600 5M HD210 Early Years 14" Monitor	ACOR £1429
Risc PC 600 5M HD210 Early Years 17" Monitor	ACOR £1829
Risc PC 600 5M HD210 Learning Curve 14" Monitor	ACOR £1429
Risc PC 600 5M HD210 Learning Curve 17" Monitor	ACOR £1829
Risc PC 600 9M HD420 14" Monitor	ACOR £1445
Risc PC 600 9M HD420 17" Monitor	ACOR £1620
Risc PC 600 9M HD420 Early Years 14" Monitor	ACOR £1729
Risc PC 600 9M HD420 Early Years 17" Monitor	ACOR £2129
Risc PC 600 9M HD420 Learning Curve 14" Monitor	ACOR £1729
Risc PC 600 9M HD420 Learning Curve 17" Monitor	ACOR £2129
Risc PC 486 Card, special offer if ordered with computer	ACOR £99
SCSI II Interface for Risc PC	CUMA £195
Ultimate CD ROM Dual Speed for Risc PC 600	HCCS £188

Portables

A-Link for Pocket Book	ACOR £43
Flash Disc 256K for Pocket Book	ACOR £46
Pocket Book 256K	ACOR £165
Pocket Book II 256K	ACOR £228
Pocket Book II 512K	ACOR £278

Printers

A4-1200/1 Direct Drive Laser Printer	CALL £978
Bubble Jet BJ-10sx	CANO £149
Bubble Jet BJ-10sx Sheet Feeder	CANO £45
Bubble Jet BJ-200	CANO £210
Bubble Jet BJC-4000	CANO £339
Bubble Jet BJC-600	CANO £359
DeskJet 500C	HEWL £245
DeskJet 520	HEWL £219
DeskJet 560C	HEWL £365
EP-L Toner Cartridge for LBP-4	CANO £59
EP-S II Toner Cartridge for LBP-8	CANO £69

ICS A3000 series hard disc upgrades

PLEASE SPECIFY OS 2 OR OS 3	
60 Mb	£190
80 Mb	£199
120 Mb	£235
240 Mb	£375
Internal Interface only	£75

ICS Archi range hard disc upgrades

PLEASE SPECIFY OS 2 OR OS 3	
240 Mb	£250
330 Mb	£299
420 Mb	£345
540 Mb	£449
1000 Mb	£699
Internal Interface only	£60

ICS Hard discs

80 Mb 2½" IDE	£139
120 Mb 2½" IDE	£175
240 Mb 3½" IDE	£200
330 Mb 3½" IDE	£249
420 Mb 3½" IDE	£295
540 Mb 3½" IDE	£399
1000 Mb 3½" IDE	£649

ICS Removable hard discs

Wizzo SyQuest 105 Mb Complete Package	£275
Wizzo SyQuest 105 Mb Complete Package for Risc PC	£299
Wizzo SyQuest 270 Mb Complete Package	£475
Wizzo SyQuest 270 Mb Complete Package for Risc PC	£499
105 Mb 3½" IDE Removable Hard Disc Cartridge	£52
270 Mb 3½" IDE Removable Hard Disc Cartridge	£55

Memory

A3000 1 - 2 Mb	IFEL £58
A3000 1 - 4 Mb	IFEL £113
A3020 / A4000 2 - 4 Mb	IFEL £74
A5000 2 - 4 Mb	IFEL £75
Risc PC 2 Mb VRAM	ACOR £195
SIMM 4 Mb 32 bit	£130
SIMM 8 Mb 32 bit	£240

Bargain basement

SUBJECT TO AVAILABILITY

1st Paint	RESO £19
Access for A3020/A4000	ACOR £129
Carnage Inc. (not Risc PC)	FOUR £11
Citizen Swift 24 Printer, ex- demonstration	£199
ColourBurst	STAT £249
Conqueror	SUPE £10
Exotic Adventures of Sylvia Lane (not Risc PC)	FOUR £16
First Words and Pictures	CHAL £10
Freddy's Folly (not OS3)	MINE £3
Good Impression	WORD £10
HiVision colour A3000/3010/3020/ 4000 internal	HCCS £79
Impact!	CIRC £25
Last Ninja	SUPE £17
Pandora's BOX (not Risc PC)	FOUR £16
Zarch	SUPE £13

Other hardware

486 PC Card 25 MHz 4 Mb	ALEP £475
486 PC Card 50 MHz 4 Mb	ALEP £525
486 PC Card 50 MHz 8 Mb	ALEP £635
A3010 2M Early Years	ACOR £399
A3010 2M Early Years Med-Res SVGA Multiscan System	ACOR £499
A3020 FD Med-Res SVGA Multiscan System	ACOR £656
A4000 2M HD210 Early Years High-Res SVGA Multiscan System	ACOR £949
A4000 2M HD210 Early Years Med-Res SVGA Multiscan System	ACOR £899
A4000 2M HD210 Learning Curve High-Res SVGA Multiscan System	ACOR £949
A4000 2M HD210 Learning Curve Med-Res SVGA Multiscan System	ACOR £899
Backplane, 4-slot 4-layer with fan	IFEL £55
DMI 30	AUDI £73
DMI 50	AUDI £84
DMI 50 - S	AUDI £162
Dongle Dangle with screw fittings	ICSD £6
Eagle M2	COMC £319
Fan Filters (pack of 10) (not A5000)	ICSD £6
High-Res SVGA Multiscan Monitor 14"	ACOR £315
Indigo CD Rom Drive CAA300iA, limited offer	CUMA £210
Lark A16	COMC £195
Logitech Mouse for Acorn	£19
Micro Mouse	CLAR £24
Midi Max	COMC £68
Power Pad (Dual)	ECLI £29
Power Pad (Single)	ECLI £22
PowerWAVE 30	AUDI £179
PowerWAVE 50	AUDI £195
PowerWAVE 50 - S	AUDI £245
RISC OS 3 Software Upgrade Kit	ACOR £77
Scan-Light 256	COMC £158
Scan-Light Video 256	COMC £199
Scan-Light Video 256 A3000/A4000	COMC £199
TV Tuner	COMC £88
TV Tuner with Teletext	COMC £157
Vision 24 508 line A3000 external	HCCS £147
Vision 24 508 line A3000/3010/ 3020/4000 internal	HCCS £134
Vision 24 508 line A5000/400/300/ RPC600	HCCS £134
Wizzo5 for A5000	ICSD £39

**We supply
a full range of
Acorn products
Please call for prices**

ICS

0151-625-1006

HOW TO ORDER

Carriage is free within main-land UK if you pay on ordering.

Cheques should be made payable to Ian Copestake Limited.

You may also pay by **credit card, debit card or Switch**.

We normally make **no charge** for this, and take no payment until goods are despatched. We need your address as known to the card issuer.

If you leave an order on our **answering machine** please include your telephone number, your card number and its expiry date (and issue number if any), and your calculation of the total payment due.

Official orders are welcome from UK educational and government institutions (invoices are due for payment within 14 days and are subject to carriage and late payment charges).

VAT is not included. Zero-rated items are marked V0. UK customers please add 17½% to all other prices. EC customers outside the UK please do the same unless you are VAT-registered, in which case quote your international VAT number. Ours is GB 595 7258 84.

Overseas carriage: If you are paying by credit card we will add airmail and insurance at cost. Otherwise please add £6 (Europe) or at least £12 (elsewhere) for each software item and send a pounds sterling bank draft payable at a London clearing bank, or Eurocheques for not more than £100 each.

All products, prices and specifications are offered in good faith and are subject to change without notice. We process all orders immediately, but suppliers do sometimes keep us waiting. Goods are guaranteed but we do not supply them on approval. Returns and cancellations can only be accepted by prior agreement and there may be a charge to cover the costs involved.

ICS

0151-625-1006

Authorised Acorn Dealer and Developer

Please make cheques payable to Ian Copestake Limited

**Dept U13, 1 Kington road, West Kirby,
WIRRAL, Merseyside, England, L48 5ET**

Tel: 0151-625 1006 Fax: 0151-625 1007

SHARPEN UP YOUR IMAGE

CALLIGRAPH
A4-1200
Direct drive laser printer

With the highest resolution printer available for Acorn computers

The Calligraph A4-1200 – the highest resolution printer available for Acorn RISC machines.

This very affordable direct drive laser printer is the latest addition to our existing range of 300 dpi A4 to 1200 dpi A3 printers. The engine is hardware enhanced to 1200 dpi, giving perfectly smooth characters and curves; print quality is further enhanced by microfine toner. The printer utilises the latest in laser technology giving very sharp and clean output with virtually no toner splatter or banding.

The A4-1200 allows you to vary the resolution of the printed image depending upon whether you need speed or quality: 300, 400, 600, 800 and 1200 dpi resolutions are available. The higher you push the resolution, the greater the number of greyscales the engine can display... no more image degradation when you raise the resolution.

Consumables are long-lasting – photoconductor kits last for 30,000 pages and toner sets 15,000 pages at 4% coverage, making it a very economical printer engine to run. Available in either single bin or dual bin formats, this compact desktop laser printer is rated at 8 pages per minute. The paper bins hold 250 sheets each. That's an hour of printing without even filling the paper trays!

The printer is supplied complete with all consumables, cables and documentation as well as RISC OS printer driver software for Acorn RISC computers.

£999
(Single-bin version)
+VAT

Easy to use software

The new printer driver software drives all the current Calligraph printers and includes many features required by professional printers and publishers producing final camera-ready copy. The software supports variable screen density – between 30 and 170 lines per inch screens are ideal – more can be designed by you.

Gamma correction is used to correct for varying density effects experienced when printing to different materials, and can also be used to perform some image correction when printing poorly scanned sprites. User-defined greyscale lookup tables perform special effects such as altering the brightness or contrast of a page, to give the output more 'snap'.

Typesetting features such as wrong-reading (mirrored) pages, negative pages and virtual sprites are supported. For quick proofing, sprites and fonts can be printed without halftoning. These features perform a level of image enhancement not available on any other printer.

The laser engine is fully controllable from your computer and printer status messages appear on your screen, this means not having to leave your machine to operate menus and buttons on the printer.



- 1200 dpi
- microfine toner
- compact design
- dual-bin version
- variable resolution
- 8 pages per minute
- software controllable

Calligraph laser printers need no extra expensive memory or fonts (unlike PostScript or Laserjet type laser printers) and produce complex pages of text and graphics in tens of seconds, rather than up to 20 minutes or more required by other printers.

CALLIGRAPH
TQ-1200
Direct drive laser printer

Also available – A3 1200 dpi laser printer and plate-maker

An integral part of the Acorn Publishing System, the Calligraph TQ-1200 produces camera-ready copy in a fraction of the time to typeset similar work. Driven by the same software as the A4-1200, it has all the features of that printer, plus control over the laser power and transfer bias for printing to non-paper materials. Calligraph specially modify this engine to print reliably on all materials. The printer is an 8 ppm laser unit capable of printing to paper, transparencies and polyester printing plates.

All standard sizes from A6 to oversize A3 are supported. An optional second paper tray unit and automatic paper feeder are available to supplement the manual paper feeder.

CALLIGRAPH
laser printers

53 Panton Street • Cambridge CB2 1HL • Tel (0223) 566642 • Fax (0223) 566643



Acorn Computing to merge into Acorn User

ACORN Computing magazine, sister magazine to *Acorn User* and the other Acorn title to be published by IDG Media in Macclesfield, is to close. The March issue will be the last *Acorn Computing* ever, and the magazine is to be merged into *Acorn User*.

The merger, which will consolidate *Acorn User's* position as market leader in the Acorn magazine market, will incorporate the best aspects of *Acorn Computing* without affecting the successful formula of the continuing title. The combined magazine will continue to be known as *Acorn User*, so for readers of *Acorn User*, not a great deal will change, except high calibre writers like Mike Cook – who had an article published in

every issue of *The Micro User* and *Acorn Computing* – will now be writing for *Acorn User*.

Acorn Computing was launched by Database Publications (later known as Europress Publications) back in March 1983, when it was known as *BBC Micro User*. Unfortunately the BBC took a dim view of the use of its name without a licence, so after three issues it became *The Micro User*. The magazine was re-launched in late 1992 as *Acorn Computing*, and became an IDG Media magazine in October 1994, along with all other Europress titles.

The merger sees the two main staff members moving off the magazine. Editor Steve Turnbull is moving into

freelance work, and Pam Turnbull will be remaining with IDG. We wish them both the very best for the future.

In the meantime, *Acorn User* goes from strength to strength. With next month's issue (April) we will become the first Acorn magazine to carry a free cover CD-ROM, as well as the normal floppy cover disc. The industry is also waiting for the ABC figures for 1994, and indications show that these figures should confirm that *Acorn User* continues to



dominate the Acorn magazine market.

Also from the April issue, the cover price of *Acorn User* will rise to £3.25 per issue, the first price rise since the introduction of the cover disc back in October 1993.

Projects galore from Beebug

UNDETERRED by the failure of sister company Risc Developments last year, Beebug is working on an ambitious collection of new projects including a modem podule, tape backup streamers, *Ovation 2* and a series of books.

Risc Developments experimented with a modem podule some years ago but the idea never went into production. Before that, Beebug produced an internal modem for the BBC Master computer. Simplification of the BAPT telecomms approvals procedure, cheaper modem components, fast growing interest in the Internet and some encouragement from Acorn has persuaded Beebug that an up-to-date dedicated modem for Acorn computers with a full-width podule slot is a worthwhile venture.

Two versions of the modem will be produced, the first – a 14.4K bps (V32 bis) data/fax device with a V.32terbo (19.2K bps) facility for compatible modems – is scheduled to be released mid-year. By the end of the year the plan is to introduce a 28.8K bps (V.34) modem with combined voice and fax facilities. Beebug will modify its *Hearsay* comms package and David Pilling's *ArcFax* application to work with the new modems. Other software, like new Internet software being developed in conjunction with

Acorn, will be able to use the modem interface directly while older packages will use a serial port emulation. Software complying with the direct modem interface will enable the standard serial port to be left for other uses. Beebug also points out that a podule modem need not be restrained by the speed limitations of pre-Risc PC Acorns.

Ready to be shipped about the time this issue of *Acorn User* appears will be Beebug's new pair of internal and external tape streamers which use standard DC2120 quarter inch tape cartridges, capable of storing up to 320Mb depending on data compression. The drive mechanisms used by Beebug are IDE hard drive interface compatible, though the external version will have a bi-directional parallel port interface for use with second generation Acorns. Prices are likely to be £499 + VAT for the external version and £399 for the internal unit, complete with a revised version of Beebug's *Hard Disc Companion* backup software.

For bigger systems, like large network servers, Beebug is also bringing out a pair of fast SCSI DAT (digital audio tape) tape streamers with uncompressed capacities of 2Gb and 4Gb, respectively. These will also be supplied with SCSI versions of the *Hard Disc Companion* software and there is a

chance the software itself will be made available on its own for people who already have their own tape drives, priced around £100. Expect to see the DAT drives for sale starting in March.

While Computer Concepts has committed most of its development effort to PC software, Beebug has the opportunity to narrow the lead CC has with *Impression* over *Ovation*. Beebug's DTP package reaches version 2 later this year and gets a number of significant enhancements like irregularly shaped frames, frames which can be rotated, new frame handling – including multi-column frames, new colour and pattern fills for frames, rounded frame corners and improved text alignment control.

A crucial plus over *Impression* will be the introduction of a full undo/redo facility in *Ovation 2*, with a variable undo buffer which can be saved with a document for later use. Also new to *Ovation 2* will be a user-definable button bar, a context-sensitive information panel and a revised toolbox with the new frame operations. Alas, Beebug says *Ovation 2* isn't expected to be out until early summer and no pricing has been fixed.

Beebug Ltd
Tel: (01727) 840303
Fax: (01727) 843198

Upgrade...

to a RISC PC

with **BEEBUG** RISC PC Specialists
ACORNS LARGEST DEDICATED DEALER

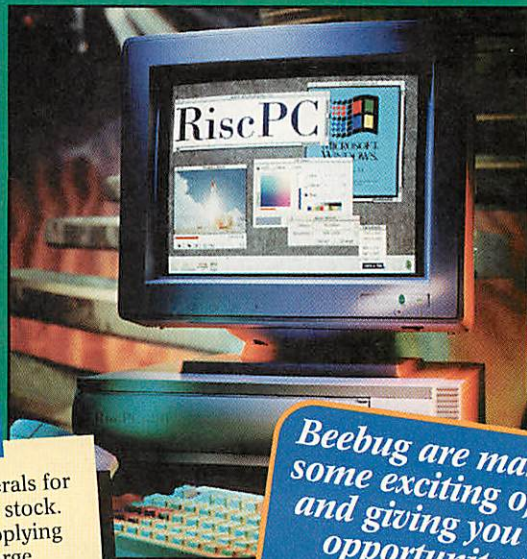

ADVICE AND SUPPORT

We have considerable experience with the RISC PC and can offer you advice on choosing your system and help with software compatibility issues. You may also need some help with RISC OS 3.5. We offer customers free on-going technical support.

UPGRADE SERVICES

Beebug offer a wide range of peripherals for the RISC PC and most are always in stock. We will fit your upgrade prior to supplying your computer for no additional charge

Beebug are making some exciting offers and giving you the opportunity to **TRADE IN** your existing Acorn computer for a RISC PC

TRADE IN

We make generous allowances for your old Acorn system. We will even take your old system back up to 3 months after your purchase of a RISC PC. Phone for a quotation. Our technical staff will copy your data from your old system to your RISC PC at no charge.

PAYMENT

We offer a number of finance options including teachers Assist and 0% as well as the usual methods. Call for a written quotation.

PRICES

Systems include a fast ARM610 processor, 1.6Mb floppy drive, 14" SVGA monitor and 12 months on-site warranty.

Code 3001g	RISC PC 600 2Mb HD210	£1249
Code 3006g	RISC PC 600 5Mb HD210	£1399
Code 3011g	RISC PC 600 9Mb HD420	£1699

For replacement 17" multiscan monitor add £400

SPECIAL OFFERS

Choose Either...
A 486 PC card for only £25
OR 0% Finance
OR Any four from Ovation DTP, Pipedream 3, Schema, Artisan II, Chess or 10 discs. Worth £200
Plus a £25 discount voucher for ProArt 24.

UPGRADES

All fitted free to your new RISC PC

Code	Memory Upgrade Type	Price
3051c	2Mb DRAM	£ 89.00
3052c	4Mb DRAM	£119.00
3053e	8Mb DRAM	£239.00
3054e	16Mb DRAM	£429.00
3048e	32Mb DRAM	£989.00
3044e	1Mb VRAM (Only for ACB15)	£129.00
3050e	2Mb VRAM (Only for ACB15)	£169.00
3049e	2Mb VRAM (from 1Mb) upgrade	£109.00

CD ROM PLAYERS

3056g Cumana CAA 300iA **£210 - Offer price**
 + free headphones until Jan 1st.
 An IDE unit with 64K cache, powered tray, 320ms access time, audio mixer, ProArtisan 2 CD and Cumana's Photo Album Photo CD. For other CD players phone for details.

MONITORS

We stock the excellent IDEK range of monitors which are suitable for use with the RISC PC
 Call for more details

IDEK 17" £ 585
 IDEK 21" £1289

Other Risc PC Upgrades

3040e	Second slice	£ 99.00
3042g	210Mb second hard drive	£199.00
3043g	420Mb second hard drive	£299.00
5216g	Beebug 420Mb second hard drive	£249.00
5215g	Beebug 250Mb second hard drive	£184.00
5081c	Econet Interface	£ 49.00
4603e	Ethernet Interface	£ 99.00
4624e	Access Interface	£115.00
3041e	PC Card and DR DOS (Available April '95)	£ 99.00
4612e	User/Analogue Port	£ 44.95
1972c	Sound Card	£ 69.00

BEEBUG

Beebug Limited, 117 Hatfield Road
 St. Albans, Herts AL1 4JS
 Tel **01727 840303** Fax **01727 860263**

UK next day delivery £8. E & OE Prices and offers may change without notice. All Prices Exclude VAT



Risc PC 486 card doing well

THE RISC PC 486 co-processor card has passed its major tests according to Acorn, who was confident enough to distribute pre-production examples to the press late in January. Our first hands-on look at the 486 card is on page 50 in this issue. At the time of writing, support software was undergoing a number of refinements, but the message is that the new card is already proving to be vastly more usable than any previous PC solution for the Acorn platform, with users of real 486 PCs likely to be convinced the Risc PC is just another 486.

However, plans for the future are already underway. Although the key 486 card custom ASIC designed by Acorn, Aleph One and Future Technologies works well enough for the first generation 33MHz 486 issue of the card, it's not yet perfect and a list of improvements is to be implemented in an enhanced ASIC which should be ready by mid-year. For the time being, Aleph

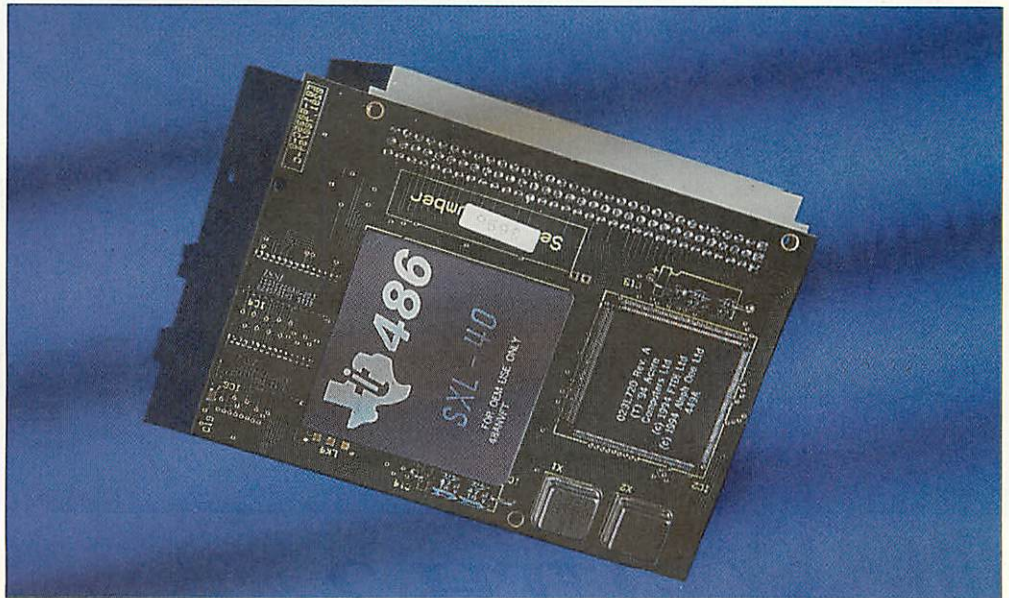

The long overdue 486 co-processor card from Acorn finally arrives, at least in a pre-production form, for evaluation by journalists and other interested parties.

One won't be producing super-fast 486 cards to complement the basic 33MHz £99 486 card, preferring to wait until the new ASIC is ready.

Acorn's Risc PC marketing manager, Peter Bondar, also rejected fears that Acorn was

only interested in the current medium performance and low-cost design, saying that Acorn would produce whatever it was that the majority of users wanted. Today, it's a 486 for £99, but in the future it could be a

DX2/66 or 100MHz DX4 processor, depending on what price/performance the majority of customers wanted. However, the message remains that if you really must have a state-of-the-art PC-compatible, buy a real one.

ARM Ltd to team up with Digital

HAD ANY doubts that ARM technology could compete with the Pentiums and Power PCs of the world? Relax, Digital Semiconductor, the chip-making division of Digital Equipment Corporation, has taken out a licence for the ARM RISC architecture. The deal promises to deliver the fastest yet ARM designs, called StrongARMs. It's possibly Arm Ltd's most prestigious deal to date, marking the cooperation of the people who make the world's most powerful RISC microprocessor (the Digital Alpha) and those who design the world's most power-efficient RISC microprocessors.

Independent technology analysts, Dataquest, commented on the deal: 'This relationship looks to be a perfect strategic fit. ARM gains access to high-performance microprocessor design and process technology, while Digital gains ARM's expertise in low-power design, as well as access to high-volume markets with significant potential. The results could have a far-reaching effect on many emerging consumer applications like PDAs, interactive TV and games.'

In fact, the StrongARMs are already

under development at Digital's US R&D centres, as well as at ARM Ltd in Cambridge. The new chips will complement and broaden the existing ARM Ltd product range. StrongARM products will benefit from Digital's experience in ultra-fast RISC designs, like its 200MHz+ Alpha series, while retaining full ARM family software compatibility.

So far, ARM microprocessors have only enjoyed modest clock speeds in production chips - the 30MHz ARM610 in today's Risc PCs, for example. However, there is the prospect of StrongARMs being produced using Digital's new 0.35 Micron fabrication process, which will enable much faster clock speeds to be applied to resulting chips. While StrongARMs will be faster than existing ARM700/800 and beyond equivalents, they will probably be more expensive and consume more power, so existing product development at ARM Ltd will continue in parallel to concentrate on low-cost and low power technology.

Nobody could confirm that Acorn would use StrongARMs in the future, though there appear to be no obvious reasons why

not, as StrongARM products will be available to third-party customers as well as Digital's own use. A StrongARM processor card for the Risc PC would be a breeze, technically. Apple has already made enthusiastic noises about StrongARM, effectively casting doubt on rumours that it was to drop ARM for a chopped-down PowerPC chip in future Newton PDAs.

From Digital's point of view, it would also appear that any plans it might have had for a version of the Alpha architecture in the ARM-dominated low cost/low power consumption arena would be in doubt too. Acorn's Online Media digital set-top box division is strongly hinting that it will evaluate StrongARMs for its future products. StrongARM power could eventually be adequate for software MPEG decompression, for example. The first StrongARM products will be available around mid-1996.

ARM Ltd
Tel: (01223) 400449
Fax: (01223) 400410
e-mail info@armltd.co.uk

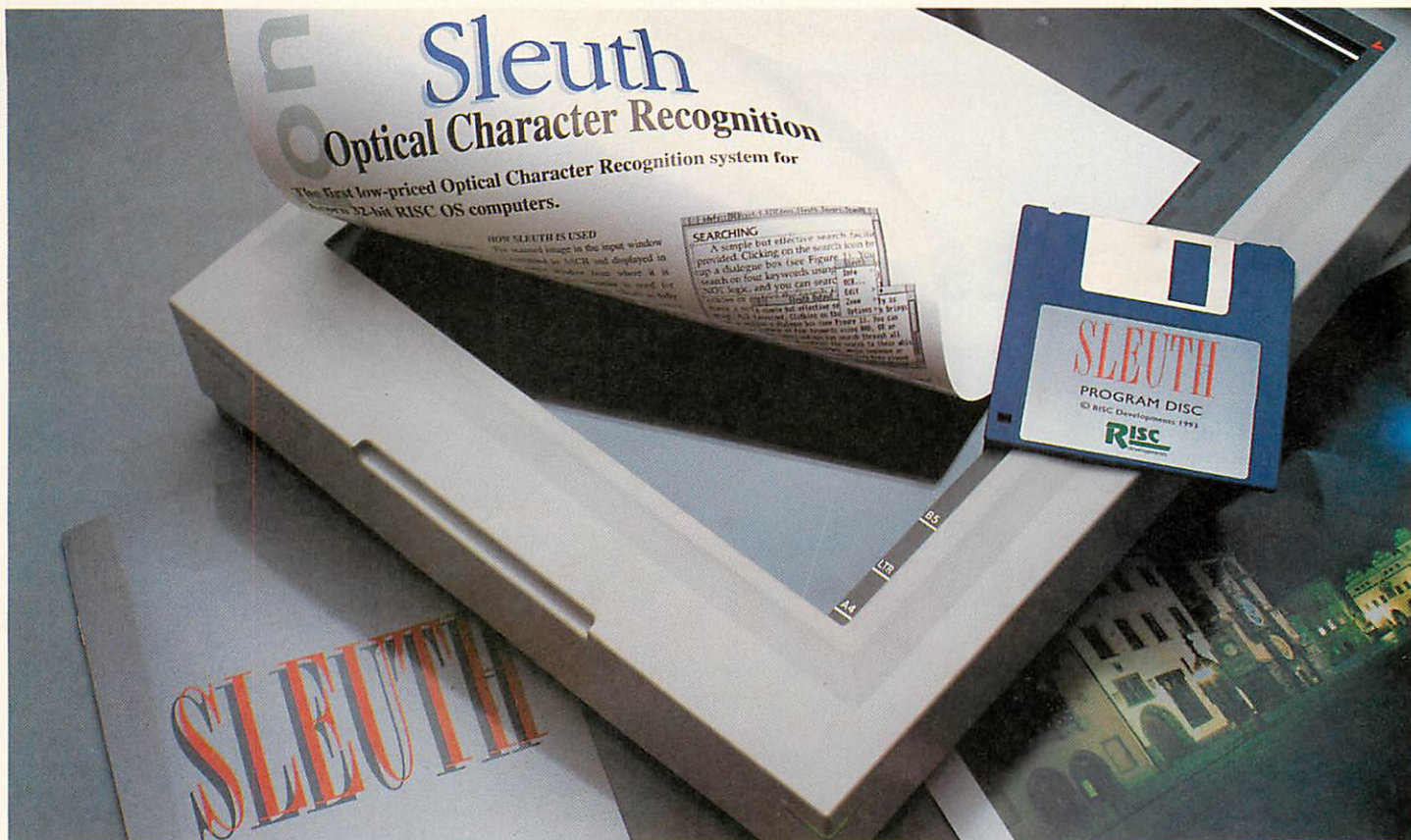

SLEUTH 2

PROFESSIONAL OPTICAL CHARACTER RECOGNITION

THIS NEW VERSION OF SLEUTH TAKES OCR ON ACORN SYSTEMS TO TRULY PROFESSIONAL LEVELS WITH SUPERB NEW FEATURES LIKE AUTO PAGE ZONING, STYLE RECOGNITION, FULLY INTEGRATED SPELLING CHECKER AND GUIDED EDITING.

SLEUTH CONVERTS SCANNED IMAGES OF PRINTED MATERIAL AND CONVERTS THEM INTO ASCII FILES. VERSION 2 CAN ACHIEVE OVER 99% ACCURACY ON GOOD QUALITY IMAGES, AND CAN HANDLE VIRTUALLY ALL POPULAR TYPEFACES IN A WIDE RANGE OF SIZES AND STYLES. ALL WITHOUT THE NEED FOR ADDITIONAL TRAINING.

YOU WILL NEED 4MB RAM AND AN ACORN-COMPATIBLE SCANNER WITH A MINIMUM RESOLUTION OF 300 DPI. SLEUTH CAN SCAN IMAGES DIRECTLY USING TWAIN DRIVERS, WHICH ARE AVAILABLE SEPARATELY.

- ♦ *Integrated Spelling Checker* — checks words as they are converted giving high levels of accuracy.
- ♦ *Recognises Plain, Bold, Italic and Bold Italic styles* — recognises and displays different weights and allows them to be exported in RTF format.
- ♦ *Automatic page zoning* — can convert entire complex pages, containing multi-column text and graphics. It converts the text in a sensible order and ignores the graphics.
- ♦ *Manual page zoning with multiple zones* — zones may be drawn around the areas of the image to be converted and links used to specify the correct order. Areas of the image can be ignored using 'ignore' zones. Zones may be saved in template files for future use.
- ♦ *Guided editing* — identifies and locates possible conversion errors for easy correction. It is multi-tasking, allowing corrections to be made whilst converting the rest of the image.

Flatbed Mono & Colour Scanner Packages from £479

- ♦ Compact A4 flatbed scanner. Either the Canon IX3010 300 dpi scanner offering 256 grey levels or the Canon IX4015 400 dpi colour scanner.
- ♦ Sleuth version 1.5.
- ♦ ImageMaster image processing software & Twain scanner driver.
- ♦ Optional SCSI interface & connecting lead. SCSI interface is required to connect the scanner.



Prices

Sleuth 2	£99
Upgrade Sleuth 1 to Sleuth 2	£49
Mono package with SCSI interface	£569
Mono package without SCSI interface	£479
Colour package with SCSI interface	£754
Colour package without interface	£664

When ordering please state the system you are using. Add £49 if you want Sleuth 2 instead of Sleuth 1.5. Please add carriage of £1.70 for Sleuth 2, £0.85 for Sleuth upgrade and £8 for scanner packages. Please add VAT to all prices.

Sleuth 2 requires RISC OS 3.1 or later.



Software and loads of fonts from iSV

BRACKNELL-BASED iSV Products has three items of news for Acorn users this month. The first is a budget-priced RISC OS spreadsheet called *TableCalc*. High on *TableCalc*'s feature list is Computer Concepts OLE (object linking and embedding) compatibility which means you can import a *TableCalc* spreadsheet into *Impression* and edit it in situ. *TableCalc* is priced at just £30 which should give the producers of *Schema*, *Resultz* and *Eureka* something to think about. *TableCalc* also has the ability to export in *Draw* and *CSV* formats.

Next up is a 277 RISC OS 3.1+ font pack, featuring 35 font families, complete with font installer, for £25. If that's not enough for you, iSV has also launched a font editor called *Font Fiend*. This can

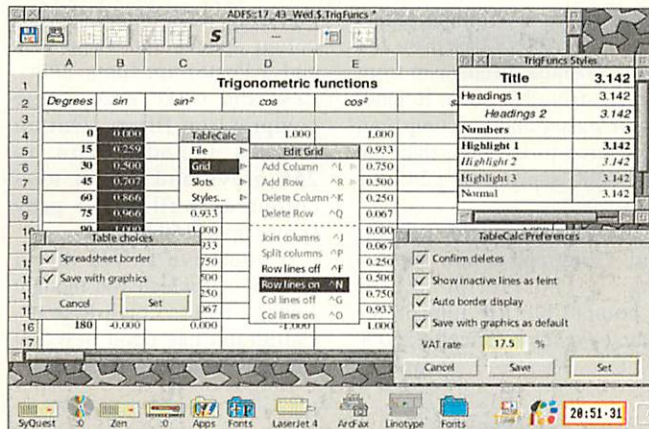

TableCalc – a budget spreadsheet from iSV.

load and save fonts with automatic kerning, automatically generate accented letters, scaffolding and skeletons, and includes other effects like flipping, rotation, excess point removal and *Draw* export/import. Skeletons,

kerning and scaffolding can also be copied between fonts. *Font Fiend* didn't have a price or release date at the time of writing. For more information, contact Aaron Timbrell.

iSV products
Tel: (01344) 55769

Meteosat images galore

A CD-ROM containing 23,000 Meteosat images of the whole earth has been produced by Musbury Consultants for the RISC OS platform. *Meteosat RISC* offers one image a day in the infra-red spectrum from 1986 to 1991, plus one a month in visible light and a selection of special images featuring snow storms, water vapour and other detail.

Three utility applications are also on the disc. *Meteosat* displays images in date order or manually by dropping an image file icon onto its application icon. It also offers palette colour control for artificial colour enhancement, plus the ability to overlay a coastal outline grid. Images can also be exported in sprite format by *Meteosat*. *PalMake* is a palette utility for advanced image colour manipulation using RGB and HSV colour models, and *SpMovie* is an animation tool to show a sequence of saved

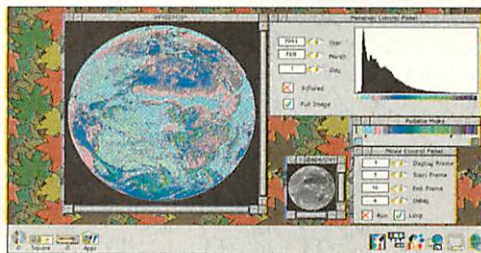

Stormy weather ahead, as seen on *Meteosat* from Musbury Consultants.

sprites as a movie. Tuned versions of these applications are also supplied to make the most of newer Archimedes facilities and the Risc PC. *Meteosat RISC* is priced £30 including P&P and VAT.

Musbury Consultants
Tel: (01706) 216701

Easier Textease from Softease

SOFTTEASE Limited has added a spelling checker with a difference to its *Textease* desktop publishing package aimed at schools. Most spelling checkers include advanced features like check as you type, for

example, but the nice thing about *Textease* is that it will highlight the words suspected to be misspelt in colour, making it easier to home in on words that really need correction, and missing out correctly spelt text like proper names

and post codes, etc. *Textease*, priced £29.50 without the spelling checker or £39.50 with one, is designed to be used by anyone from six years of age and up.

Softease
Tel: (01684) 73173

Fireworkz trends the boards

A couple of years back, *Acorn User* ran a news story about a TV actor, Nicholas Day, who wrote a RISC OS labelling utility in between shooting programmes like ITV's *Minder*. He's still an Acorn fan and his latest project – a production of Patrick Marber's *Dealer's Choice* at the National Theatre – will feature a PC on stage running the Windows version of Colton Software's *Fireworkz* package. The *Fireworkz* application running on the stage was developed by Nicholas Day on his Archimedes at home.

PhoneDay is coming

On April 16th, PhoneDay, most of the UK's phone numbers will be changed, mostly with a '1' inserted inbetween the leading '0' and the rest of the area code, though Leeds, Sheffield, Nottingham, Leicester and Bristol will have a completely new area code. The international dialling prefix also changes from '010' to '00'. *Acorn User* would like to hear from anybody devising solutions for updating telephone database records for PhoneDay on any Acorn platform, be it a BBC Micro, Archimedes or Pocket Book. Send your details to the News Editor at *Acorn User* or e-mail him at iburley@cix.compulink.co.uk

Oak Recorder 2 update

SoundLab, the audio editor application supplied with Solent Computer Products' Oak Recorder 2 sound sampler, has been overhauled and now has a trendy button bar plus new edit options, like amplify, fade, echo and low/high pass filtering. *Armadeus*, *Acorn Replay* and *PC WAV* file compatibility is also added. Wave form graphics can be exported to graphics packages in *Draw* or *Paint* format too. Oak Recorder 2 and 3 packages remain un-changed in price at £50.47 and £56.34 respectively, inc. VAT and carriage, while the software upgrade cost for existing users is £9.95 + £1 P&P + VAT.

Solent Computer Products
Tel: (01954) 789701
Fax: (01954) 782186



News trio from Calligraph

CALLIGRAPH, the Cambridge-based fast laser printer specialist, has announced a new printer, a new direct laser controller printer podule and a new *PostScript* Level II-compatible RIP (Raster Image Processor). The new Calligraph A3-1200 printer uses the same Toshiba internals as its sibling, the Calligraph TQ-1200, but costs £1000 less.

The savings come from a simpler sheet feeder and the absence of *PostScript*. Both models can print at software-selectable resolutions from

between 300dpi and 1200dpi at eight pages per minute in A4 paper mode or four ppm in A3 paper mode. Calligraph points out that printers based on the same Toshiba mechanism from models from NewGen, Roland, LaserMaster and Calcomp, can cost three times more than the A3-1200's price of £2450 + VAT.

In conjunction with Rapport Ltd, Calligraph is now supplying a *PostScript* Level II-compatible RIP interpreter called *PostDoc*, priced £250 + VAT. *PostDoc* supports

Rational Tangent (RT) halftone screening and TLA (True Linear Approximation) screening, Grey, RGB, CMYK and CIE colour spaces and Type 0, 1 and 3 *PostScript* fonts, JPEG, LZW and CCITTFAX image compression filters. Output formats include *Draw* in 256 greys and 24-bit RGB colour as well as 16 grey sprites up to 150dpi.

If you have an old direct laser printer which you thought couldn't be used on a Risc PC, Calligraph has good news. It has redesigned its direct laser

printer podule interface to enable old Qume and Taxan liquid crystal shutter printers, previously supplied by both Calligraph and Computer Concepts for their respective direct laser printing systems, to be Risc PC-compatible for the first time. The podule plus v.3.00 printer driver software is priced £130 + VAT on its own or £250 + VAT with the special 300dpi version of the new *PostDoc* RIP.

Calligraph
Tel: (01223) 56664
Fax: (01223) 566643

Smart DTP's new angle on clip art

WHEN IS a clip art pack not a clip art pack? When it's a DTP and design resource, says James Parry at Smart DTP in Belper, Derbyshire. A product Parry says goes beyond the bounds of ordinary clip art is his company's new *PublishArt* package. While *PublishArt* contains a library of pre-drawn material, that's where the link between boring clip art libraries and *PublishArt* ends, he says.

What the *PublishArt* message seems to be is that the clip art contained in *PublishArt* is designed to be more useful than a

miscellaneous collection of pretty drawings. For example, *PublishArt* has categories like Backdrops, Patterns, Symbols, Highlights, Page layout and Stencils. One category is called Quickpaper, which contains A4 sized drawings designed to quickly and easily customise a page of text. 'Why settle for boring white paper?' Parry asks. *PublishArt* contains over pre-drawn 500 designs in *Draw* and *ArtWorks* format compressed into three floppy discs, priced £29.95.

Smart DTP
Tel: (01332) 842803

Oregon launches digital video editor

CALLING all users of Eagle M2 and Irlam digital video capture cards, Oregon Developments has announced a new digital movie editing package called *CineWorks*. The new package is designed to manipulate MPEG and *Acorn Replay* digital video clips and provides a 32-track video mixing and editing studio plus 16-track audio.

CineWorks can perform fancy wipes and fades plus mosaic transformations and central zooms. Other effects

available include zooming, panning, rotation, shadowing, ghosting, chroma-keying and opacity control. Visual correction, using brightness, colour and contrast controls are also featured and can be dynamically adjusted throughout a clip. Genlocking is another area *CineWorks* has been developed for, with 16 levels of transparency, supporting most Acorn genlock hardware.

Oregon Developments
Tel: 0121-353 6044
Fax: 0121-353 6472

Blinding new package from Quantum

ARE YOU frustrated with the RISC OS 3 desktop pinboard facility? Quantum Software might have the answer in the form of its new *Blinds* product, described as a productivity tool that uses windows-containing programs, files, directories, etc., in a 'never-before-seen manner.' Putting it crudely, *Blinds* is a drop-down pinboard which leaves your desktop screen clutter-free.

Blinds containing collections of application and file icons can be set to drop down, pop up or slide open from one side. You can create as many blinds as you like, collecting icons in recognisable groups. You can also give icons long names and select from over a thousand icon sprites to replace boring icon graphics. Another neat

feature is the ability to save a file from an application without needing to find the correct destination directory. You can associate a target directory with an application and by dropping a file icon onto the blind containing that application, the file will be automatically saved in the right place.

Blinds will also work with another Quantum utility, *Keystroke*, enabling *Keystroke* users to build a custom *Blinds* icon bar. *Blinds*, programmed by Stuart Halliday and Alisdair Jørgensen, is priced £19.95 and a public domain demo version is available.

Quantum Software
Tel/fax: (01506) 411162
e-mail quantumsoft@digibank.demon.co.uk

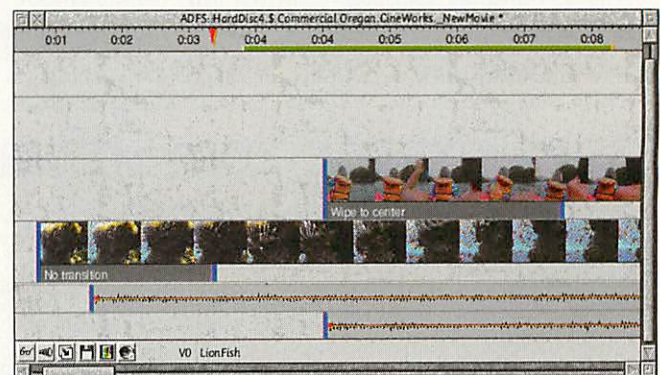

Video editing with *CineWorks*.

An ultra hi-performance fileserver

nucleus

Nucleus is an ultra high-performance fileserver for Acorn networks. It offers greater speed and flexibility than any other Acorn based server whilst remaining backwards compatible with older generation networks and computers.

Care has been taken to streamline every aspect of the design so that Nucleus performs well even under extreme load from large nets. The product has been designed to handle upwards of 100 computers.

Larger hard disks, larger files, larger directories, faster loading and saving, improved printing and far more powerful management tools are just some of the improvements provided by Nucleus. Phone for a brochure or to request a demonstration.

Pricing

Nucleus 1-10 stations	£ 199.00
Nucleus 11-25 stations	£ 399.00
Nucleus 26-50 stations	£ 549.00
Nucleus 51-100 stations	£ 749.00
Nucleus 100+ stations	£ 1,299.00

Nucleus Linkable Components (NLCs)

CD Server NLC	£ 199.00
Netgain NLC – fast application server	£ 199.00
Digistore NLC – tape backup software	£ 79.00
PC Connect NLC – for DOS connectivity	£ tba

digital services

9 Wayte Street, Cosham, Portsmouth
Hampshire PO6 3BS Tel 01705 210600

CD sharing for networks

CD server

CD Server is a software product which allows one or more CD-ROM drives to be shared over a network. To the network clients, it is just as if they have a local CD-ROM drive attached to their computer.

By allowing every station on your network access to a single CD-ROM, CD Server saves the massive costs involved in purchasing a drive for each computer. CD Server will transform multimedia accessibility on your network.

Available either as a stand-alone server or as an NLC.

CD Server software £199.00

All prices shown are ex-VAT, which is chargeable at 17.5% on all items shipped within the UK.
Please add £1.50+VAT carriage to all orders.

Colour Scanner & Multimedia Update

Teletext, NICAM Digital Stereo & TV Tuner

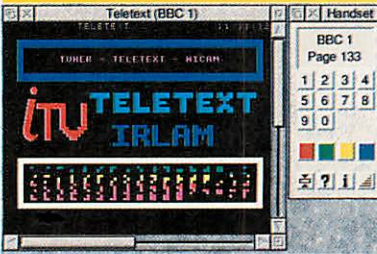

ITV is a complete television reception system with TV tuner, Teletext and NICAM stereo audio decoder on a single expansion card.

ITV is simple to use with Channel and teletext page selection all carried out from a single RISC OS application.

As well as generating stereo audio & video, **ITV** can also switch in an external source so that you don't have to mess about swapping leads. A composite video output is provided to drive digitisers - with integral support for the **24i16** multimedia system.

- ▶ Teletext & NICAM support **as standard** including all software.
- ▶ Crystal controlled full-band tuner receives VHF/UHF from aerials, cable or VCRs etc.

ImageBank - £31.14 inclusive VAT P&P



With a copy of **ImageBank** you can squeeze ten megabytes of 24 bit scans onto a single floppy disc, and catalogue them too!

ImageBank compresses pictures automatically, creating 'thumbnail' versions so that you can browse through them quickly and easily.

Double clicking on the thumbnail rapidly decompresses the image to its full size. Acclaimed in reviews as an invaluable utility.

24 Bit COLOUR Hand Scanner

The first Colour hand scanner for RISC OS machines. Supplied complete with a specially designed expansion card and application software for A400, A5000 and Risc PC. From monochrome or 256 grey scales up to full 24 bit scans this scanner does them all brilliantly. But don't just take our word for it:

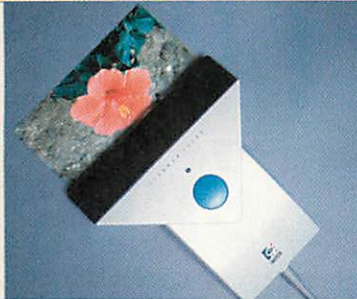

"Irlam has led the way in bringing high quality colour scanners to the Arc..The first affordable 24-bit colour scanner...Irlam has obviously put a lot of effort into getting the best possible images from the scanner, and the images that Prol-Mage generates are excellent..an excellent product at a very reasonable price" - RISC User

"I was most impressed by the quality achieved by this handy unit...The entire package works very well and produces stunning results" - Archimedes World

Unlike many hand scanners this package is easy to use, scans straight and produces brilliant results. Features include:

- ▶ 24 bit scan head providing 16.7 million colour & 256 grey levels.
- ▶ Real-time high-quality preview whilst scanning direct-to-disc.
- ▶ Resolution up to 400 dots per inch.
- ▶ Powerful colour map controls allowing RGB components to be adjusted individually and effects previewed in real-time.
- ▶ 32 bit sprite format & takes advantage of new Risc PC modes.
 - ▶ 24 bit Clear & industry standard compressed TIFF and JPEG files.
 - ▶ Brightness, Gamma correction and Sharpness controls.
 - ▶ Visual and audible warning if scanning speed is too fast.
 - ▶ Images can be rotated and cropped after scanning.



24 Bit Video Digitiser & 16 Bit Audio Sampler

24i16 combines an advanced video digitiser with a 16 bit sound sampler. As well as brilliant still images **24i16** captures superb Replay movies and hi-fi audio.

A standard **24i16** can grab a complete TV field at a resolution of 768 pixels by 288 lines from any S-Video or composite source.

With the 1Mbyte VRAM option, full frames (768 by 576) can be obtained from still video sources. Replay movies (including sound) can also be captured at up to 25 images per second. Image size and rate are adjustable and limited only by disc and system bandwidth. A sophisticated application is provided which is both flexible and easy to use. Features include:

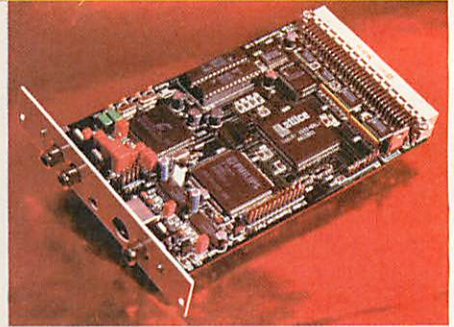

- ▶ Hardware scaling & anti-aliasing.
- ▶ Contrast, hue, brightness and saturation control in real-time.
- ▶ Real-time video expansion port for future connection to other hardware.
- ▶ Built-in ADPCM audio compression.
- ▶ Mixing and high quality filtering of built-in Acorn sound system.
- ▶ SWIs and example programs available to allow easy use from your own programs.
- ▶ Optional waveform monitor and vectorscope utilities.



Epson Colour Flat-Bed Scanners

Epson scanners are fast, reliable and produce consistently high quality scans plus they have the added advantage of supporting transparency adaptors. They can all be driven directly from the printer port of A3010, A4000, A4, A5000 and Risc PC so no expansion card is necessary (although there is one for A400's etc).



They can also work via Acorn, Cumana, Morley or Oak SCSI cards.

GT6500 This model scans at 300dpi (optical res) and interpolates up to 1200dpi in colour. SCSI interface is optional.

GT8000. 400dpi (optical) resolution and interpolates to 1600dpi. This has built-in parallel and SCSI ports. Faster than GT6500.

GT9000. This is the latest model. It scans at 600dpi (optical) and interpolates up to **2400dpi!** Scans are digitised internally to 30 bits which ensures that detail is faithfully reproduced even in dark areas. Has built-in parallel and SCSI ports.

Transparency Adaptor. This optional unit fits any Epson scanner and allows slides and black and white negatives to be scanned up to 5" x 5".



Prol-Mage scanning software has been developed over several years. It is proven, easy to use, produces high quality images and supports a wide range of image formats including industry standard TIFF and compressed JPEG files. We can supply complete packages (see below) or just software.

Prol-Mage includes:

- ▶ Multi-tasking scanning with images building up on-screen.
- ▶ Fast previews and scanning direct-to-disc for large images.
- ▶ Superb 256 colour sprites plus 16 & 32 bit for Risc PC.

For the Complete Picture contact:

Irlam Instruments Ltd, Brunel Institute for Bioengineering, Brunel

University, Uxbridge, Middlesex, UB8 3PH. Tel/Fax 01895 811401

All hardware products come with 1 year full guarantee. E&OE.



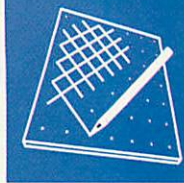

Textures and tints – at last

WITHOUT effective use of graphics, the potential power of desktop publishing would never be reached. There are many CD-based products on the market already which contain industry standard EPS and TIFF format graphical clip art for use in desktop publishing, and also entire packages dedicated to pattern and texture generation for use in graphic design and DTP.

For lower-end users without megalithic memory reserves and with no CD-ROM drive, the resources are much more limited and are touching on non-existent on the Acorn platform.

The leading Acorn reproduction house TJ Reproductions has compiled a range of tints and textures. These have been both computer-generated and captured by traditional photography, and then scanned using professional drum-scanning equipment.

The textures in the provisionally named *Texture Folio* will be available at various resolutions according to your needs. Resolutions of the tints which are designed to enhance



A simple application of one of the computer-generated tints.

DTP layouts and designs range from 800 by 600 to 3200 by 2400 and have been squeezed and squashed onto a number of media; optimised JPEG has enabled 64Mb (eight 1600 by 1200 24-bit tints) to be shoe-horned onto a single high density disc.

For higher-end users, customised tints will be available on CD-ROM, though at a

premium I'm sure. The price for *Texture Folio* has not been finalised yet but a ten high density disc pack with over 80 tints – that's 640Mb worth – will probably cost under £30. An OPI service will be offered for those who can only handle lower resolution tints due to hardware constraints.

TJ Reproductions
Tel: 0171-372 4430

Picture of the month

SUPERB attention to detail is the outstanding quality in this month's winning picture by Chris Hutchinson, aged 16.

Chris has made excellent use of graduated fills in the delicate shading of the cycle components to give the various elements a truly metallic feel. Note also the impression of shadows cast by the chainwheel onto the frame.

Chris wins £20, and you too could be the winner of this esteemed prize. However young or old you may be, please send your entries in – remember the artwork is judged relative to age and equipment used – and don't forget to send a text file with your name, address and how you created your masterpiece along with your entries.

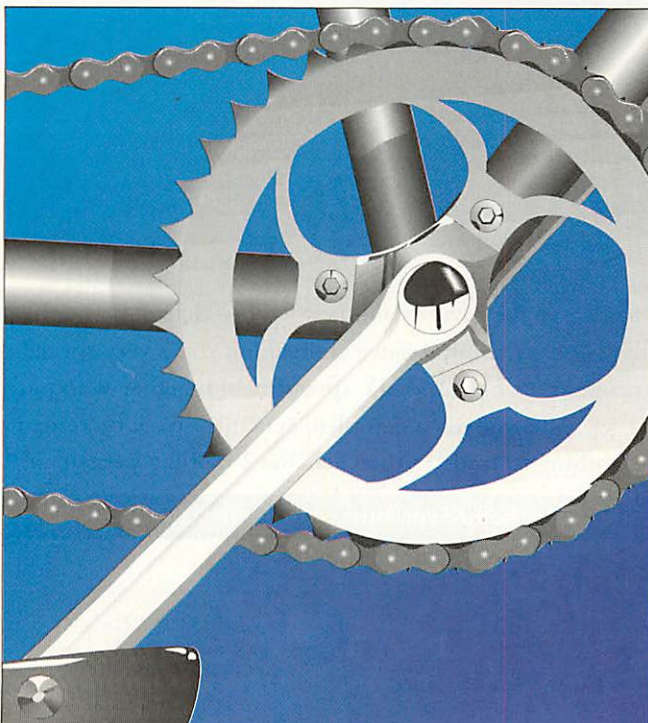

Cycle, from Chris Hutchinson.

CAD fad

Appolonius PDT is the latest software release from Oak Solutions. The package, unlike other CAD packages, uses an eerily simplistic user-interface with a tool bar that will be far less daunting to a CAD fresher than the standard myriad of tools which one is usually confronted by.

The demo software did not allow full exploration of the package so I am reluctant to comment about its best features as I may not have discovered them yet. Safe to say though, that the parametric nature of the 'intelligent' tools that are contact sensitive to the cursor and other objects greatly improves the ease of use and flexibility of the tools.

Appolonius will be reviewed in full in the next couple of months.

Oak Solutions
Tel: 0113-232 6993

PDS goes 24-bit

Spacotech has tuned up its image analysis software, *PDS View*, to take full advantage of the Risc PC's 24-bit graphics capabilities. In lower than 24-bit colour modes, *PDS View* now uses the same dynamic error-diffused dithering technique as implemented in *Photodesk*.

On the subject of *Photodesk*, Spacotech has announced improvements to the scanning capabilities of its photo retouching package. These include direct monochrome modes with the supported Canon flatbed that the company sells with *Photodesk*.

I know that Spacotech will be featuring some very innovative new concepts with a revamped *Photodesk* at the Harrogate show and will be offering a photo-realistic printer and *Photodesk* bundle for 'under a grand.' Book your tickets now.

Spacotech
Tel: (01305) 822753

Contacting me

You can contact the Graphics page by writing to me, Jack Kreindler, at *Acorn User*, IDG Media, Media House, Adlington Park, Macclesfield SK10 4NP, or by e-mail to: jack@acornusr.demon.co.uk.

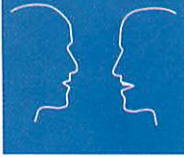

ANT web is BETT's best bet

EVEN Acorn was surprised by the unheralded appearance at the BETT show of ANT Ltd's *Internet Suite*. It includes the most professional-looking RISC OS World Wide Web browser I've seen so far, provisionally called *Fresco* – a subtle joke on another platform's Web browser name – primarily written by ANT's Nicko Van Someren, and ready for pre-release demonstration just in time for the show.

The *ANT Internet Suite* also features a drag-and-drop ftp filer with background downloading, its *Marcel* e-mail and newsgroup reader and writer package. A flexible interface for other Internet tools is being developed, such as Gopher, Archie, Telnet, Finger and interestingly for schools, educational establishments and other organisations, RISC OS Internet WWW and ftp servers. I am certainly looking forward to a hands-on review of this package.

Acorn's own WWW browser is yet to appear, but its new Ethernet and Internet e-mail

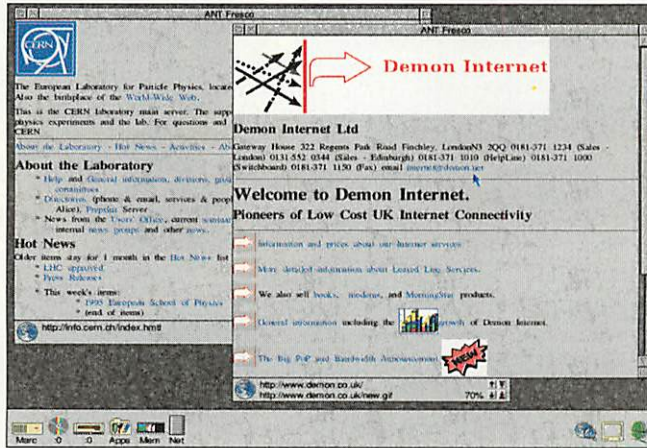

ANT's Web browser wowed them at the show.

and news package, *InterTalk*, was on show. This allows controlled access to newsgroups, sites or individuals both on a local area network and via a dial-up service provider using just one Internet address with the accent on ease of installation, set-up and administration.

Supreme Software Systems Ltd were showing the latest version of *Archiboard*, the BBS software package for dial-up

modem and network access. This package now includes Internet access and the MIME file-attachment standard for BBS mail, e-mail and newsgroup exchange of any kind of data. A hypermedia version was on show, allowing RISC OS fonts to be used on-screen on the client terminals, giving a novel full-colour webby graphic look to bulletin board menus, with point-and-click-on-icon selection.

Termite – comms software with style

I HAVE been trying out an early production version of DoggySoft's *Termite* communications package, or communications environment as its Info window says. I'm sure I've seen that somewhere before. Well anyway, *Termite* is intended to be plug and play and includes some pre-defined set-ups based on the idea of styles, which define all the parameters for the session.

Termite allows you to define various styles, offering different selections of features such as file transfer protocols, terminal speed, emulation, modem type and so on, and each time you add a new BBS or service to the dialling directory, you apply the style most appropriate from a Style list. The default style is a general purpose starting point. If required, you can create a new

style or sub-style, or edit an existing one to add to the list of choices.

The software comes provided with a dialling directory of about eight popular Acorn BBSs, including the Support BBS Furzefield Hq. As each function of *Termite* is a separate module, adding extra features or updating existing ones is simply a matter of logging onto the Support BBS as a registered user to download the latest free upgrade version of that module.

Termite's ANSI colour emulation uses an intriguingly different and distinctive font style, and as the ANSI implementation is PC compatible, all the colour and brightness codes are displayed correctly, which shows that some text and background colour combinations are less effective than

you might think. On the version I tried, only ZModem was available for file transfer, and both uploading and downloading performed well, a slider bar showing the progress of the transfer. The download function seems to employ the 'streaming' ZModem protocol, where data is sent continuously without acknowledgement until the end of the file is reached or an error is encountered. With an error-correcting modem, this gives a very high transfer rate.

When *Termite Internet* is available, registered *Termite* users can upgrade by paying the difference. If you have a copy of *Termite*, watch the Info window for a few moments – it's a moving experience!

DoggySoft
Tel: (01494) 673222

Digitax is back

Digitax BBS, originally run at the home of Graeme Read, has a new Plymouth site and telephone number. Paul Howlett joins as co-sysop, and the BBS is running *ARCbbs* on a Risc PC with a US Robotics 14k4 Sportster modem. The BBS needs more callers, files and messages, so get dialling.

Digitax BBS
Tel: (01752) 261434

Rich in Maida Vale

Richard Paddle's Rich in Paradise BBS has moved, with Richard, to a new location in Maida Vale, London. Rich in Paradise BBS is running a beta-test version of Hugo Fiennes' *ARCbbs* version 1.64 BBS software on a USR 28800bps modem and with 24-hour access. A showcase for Richard's ANSI BBS games, iP now also has free Internet e-mail access.

Rich in Paradise BBS
Tel: 0171-624 0740

Internet talk

The Suffolk Acorn RISC Club talk on 13th April will be about the Internet, and will include demonstrations of World Wide Web access, e-mail and news. The meeting starts at 7pm in the Ipswich Central Library meeting room (use the side entrance in Old Foundry Road). The Suffolk Acorn Risc Club meets on the second Thursday of each month in Ipswich library, and they plan to have more comms talks soon.

Paul Skirrow (chairman)
Tel: (01473) 728943
Andy Keeble (secretary)
Tel: (01473) 216424

Contacting me

You can contact the Comms page by writing to David Dade, Acorn User, IDG Media, Media House, Adlington Park, Macclesfield, SK10 4NP, or by e-mail to: David@arcade.demon.co.uk, Netmail to David.Dade.FidoNet#2:254/27.0 or mail #2 on Arcade BBS 0181-654 2212.

RISC user

The No. 1 Magazine for Practical Help

● COMPREHENSIVE REFERENCE LIBRARY

Back issues are available along with rapid indexing software.

● INTERESTING FEATURES

Essential reading for beginners and experts alike, providing comprehensive information on a wide range of topics.

● PRODUCT REVIEWS

Critical reviews of the latest products as they are released. Comparative surveys to help readers make the right choice.

● HINTS & TIPS

Short cuts, problems solved and mysteries unveiled.

● SUBSTANTIAL DISCOUNTS

Save 15% on software and 5% on hardware from BEEBUG's own range of products. Subscribers can more than cover the cost of a subscription for a whole year with a single purchase from our catalogue.

● LATEST NEWS

Up to the minute news about what's happening in the Acorn marketplace.

UK New
Member
£21.90



To subscribe or receive further information telephone 01727 840303 NOW!
BEEBUG Ltd., 117 Hatfield Road, St Albans, Herts AL1 4JS

Finding life in the PC jungle tough? Then you need... The Ultimate Guide for Survival

PC Survival Guide



BEEBUG

ONLY £5.95 ex. postage
(Code BKP1b)

BEEBUG Ltd., 117 Hatfield Road, St Albans, Herts AL1 4JS
Tel: 01727 840303 Fax: 01727 860263

What do you want to be able to do?
Play games or use Windows.

What equipment do you already have?
A vintage A310 or a Risc PC.

What are you going to need?
A software emulator or an ultra fast 486 card.

How much is it going to cost?
How much are you prepared to spend?

Whatever your Acorn computer, if you want PC compatibility this is the book for you. PCs are in a different world and there is a great deal you should know before making a decision that could cost you dearly later.

The Beebug PC Survival Guide covers in detail the wide range of options available for running PC software AND hardware on your Acorn computer.

The various software emulators and hardware expansion cards, including Acorn's new Risc PC 486 Card, are examined in depth. Hardware and software requirements are detailed, and solutions provided for common problems.

Whichever PC operating system you want to use, you'll find the information you need in this invaluable guide. Easy-to-follow 'hands on tutorials' make installation problems a thing of the past.



The challenge?

RISC OS has many revolutionary features and an awful lot of nice touches to it but – let's be honest – it is a little dated and lacks various elements almost essential in a modern OS.

Anyone with a PC enjoys an operating system that is at best described as flaky, but which at least has a virtual memory system. Thus an 8Mb PC can blunder about with a 24Mb TIFF or two. Admittedly, the hard drive goes berserk and the machine crawls, but it'll get there. If you want to play with 24Mb TIFFs on an *Impression* page, you'll have to fork out five or six hundred quid for an impressive array of SIMMs.

There are other essentials too: threading, PC-compatible OLE2 clients and the like. All are soon due to put in an appearance on both the Mac and the PC thanks to a new OS for each. Rumours abound in the Acorn sphere of an upgrade for RISC OS 3 and a subsequent but completely independent – read incompatible – RISC OS 4. This is an

interesting approach that Acorn appears to have developed over the last ten years – it plays its cards close to its chest and goes for the big launch.

This is at odds with the computer industry as a whole, which tends to announce things ridiculously early. Windows 94 has rapidly become Windows 95 and is looking increasingly likely to be re-badged Windows 96 before any real quantities ship. However, Apple and PC developers have been receiving detailed specs for their respective OS replacements for some time, and Windows 95 is expected to launch with at least a couple of hundred major packages already re-coded to make use of its new tricks.

Compare this with Acorn's launches which tend to come long before any support appears. Both Apple and Microsoft have been publishing fairly detailed development environments and specs for the best part of a year. Just about everyone knows what these new operating systems will

contain. There may be lots of delays but there won't be any surprises and the ground is well prepared for these new operating systems to flourish upon. Acorn, however, is tight-lipped about both a date and a list of features and this uncertainty can't do anyone any good, developers or users alike.

So is Acorn confident enough to show us some of its cards or are we all expected to decide for ourselves whether it's bluffing or holding a royal flush?

As a parting thought, if you're running a PC card in an Archimedes (rather than on a Risc PC where memory is shared between Windows and RISC OS) you'll have more memory available to Windows than you will to RISC OS, although I imagine you'll need a fairly large chunk of RAM to run them both side by side. When Windows 95 finally gets here it'll offer multi-threading and the like for less than £100. Is RISC OS 3 really up to a challenger like that?

Another sapling Acorn tree?

In a month when Apple has fallen out with several suppliers, Acorn's professional sales (publishing) division appears to be a positive hive of activity. Another distributor has joined forces with Acorn to sell Acorns into a traditionally Mac-blinkered environment. Rapitech is well known throughout the printing and reproduction arena as a supplier of pre-press solutions and equipment.

Rapitech has plenty of experience selling both Macs and PCs but is now planning to use Risc PCs as well. The Acorn's ability to talk to both platforms without too much fuss means it can happily sit in a mixed environment already containing both Macs and PCs.

The Risc PC is set to be used as a fairly high-end production station for repro houses which means it'll be competing with the Mac on its home turf. The current partnership with AB Dick isn't affected by this new suitor. The Risc PC-based Graphtex systems will continue to be sold as part of the AB Dick range.

Clips galore

Just about everyone is launching new or improved clip art libraries. Alongside additions to the Smart DTP collection and the Photobase collection from Longman Logotron, the Arc's new found Internet skills mean you can go and play with the Sunet picture archive.

Just point your ftp client at <ftp://ftp.sunet.se/pub/pictures/> and you'll have access to all manner of pictures from landscapes and comic art to TV and movie stills. The images are mostly copyright-free and tend to be either GIFs or JPEGs. Viewing them shouldn't be a problem but some of them are pretty big so a swift modem is essential.

Contacting me

You can contact the DTP page by writing to me, Steve Powell, at *Acorn User*, IDG Media, Media House, Adlington Park, Macclesfield SK10 4NP, or by e-mail to stevep@acornusr.demon.co.uk.

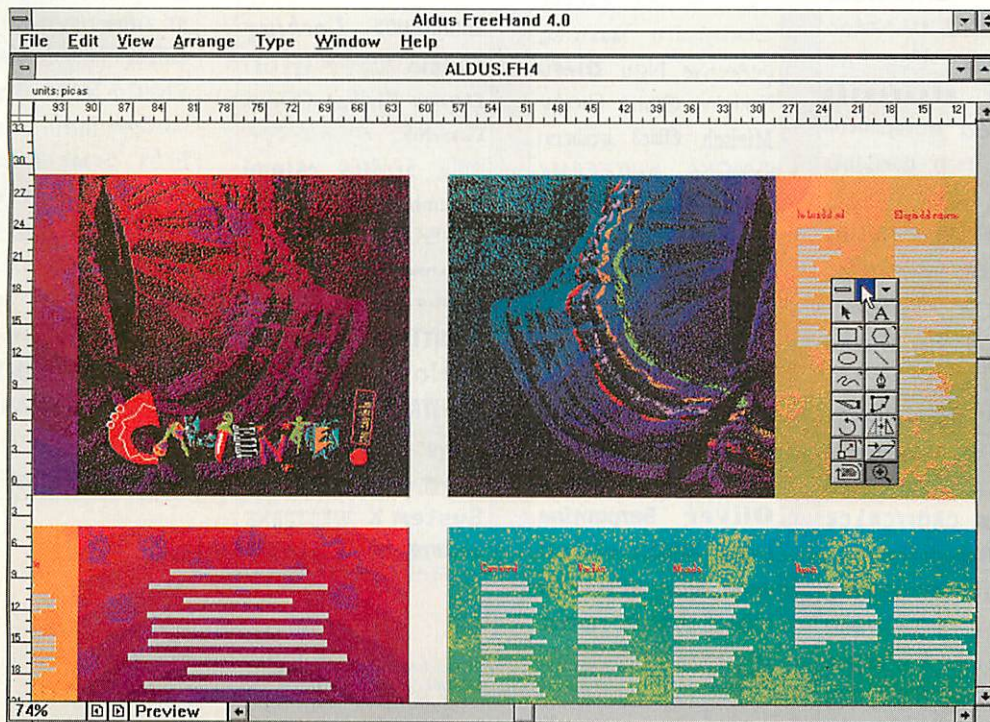

The prospect of having to skip off to Windows to load a big picture like this one rather than using RISC OS is galling to say the least. A virtual memory system isn't just overdue, it's in danger of arriving long after the party's over.

500 LOWCOST FONTS

SKYFALL



Font Pack 1

Buckingham *Friendly* Jotter
garden *Chicken*
Schwarz Select
THEATRE Ladybird
Amber Milton Keynes
Gangster Bit Columbia
Bolt Classic Koch
Palatino Hardcase Swizz
Oxford Citric Trio
Reiner Baskerville
Cooper Black Old English
MegaType Park Avenue
YOUNG Brush Script
Acorn **TECH** *Jayne*
STENCIL Orange
SPLONGE Dubiel
ALGERIAN SOLID
BALLOON Lazy Σμμβολ
Raven George *****#00**
SCOP *Itali* **IIIIIIII**
Cyberoid XRMMk IT

Font Pack 6

RoughBrush **S.H.A.P.E.N.E.I.**
DINOSAUR STARBURST
InkyType RHYOLITE
Pure Babe Premium
NATURAL Natural
Azward **skoolkid2**
Jazzy Lines **SNAZZY** Frog
IIIIII **IIIIII** **IIIIII** **IIIIII**
kentwires **Ola Messy**
BellBottom **Pieces**
Wide Base **CROSSROADS**
Cross Wits **MultiLine**
HAIR **GLASS**
GRUBBY **IIIIII**
DIEGER Western 1
STERLING Western 2
Bradford LED White **WESTERN 3**
Empty Times Open **WESTERN 4**
Prefix **ZpALONG** Yamato
ZARROW **RELIEF B**
PEE/WAX skull **RECTFONT**

Font Pack 2

POST CRYPT *Wine* Murder
Fox Script Ricksaw
Informal Chasline
Architect Phaedrus
Chinese Kathlita
TERMINATOR Borzoi
Thalia Caligula *Alison*
Psychadelic El Garrett
Heidelberg Jackson
Laser Square Black
Andromeda Charlie
FLINTSTONE Canaith
METRO LINER Future
Циркуль EDDA LED Style
CAVEMAN Video Graphic
Jumbajaya Oregon
Daytona Windsor **PONCHO**
BUBBLE **SNYDER**
New Sweet **ESPERES**
TEBY Gordon DEUSEX
China TOWN **STRONGMAN**

Font Pack 7

Exposed **EricContor**
GLASSLITE **ALPHABET**
WETPAINT **HAPPYHOR**
NLQ InkJet **HEADDANCER**
Knotted **HORRORPLUS**
Naked **Freak** **HERZLINES**
ROMANBLANC *Underline* **HOTTEL**
SCORP EtreOpen **SKILINE**
ENGRAVER **SPAKESTRIP**
SysError **zapopen**
futuretra **Faustus** **GREKO**
DownWind **Woid** **unwhite**
After **Speed** Upright
ApexRix **Camberic**
Edged **White** **COMB**
Brocks **CROSSCRACK**
OOOOO Brighton
SCRATCH **Vancant** **Cyborg**
Ballet **Flawed**
Gheers **Zeppe**
DingDong **FLASH**

Font Pack 3

DEASHIN **MULTICOLOR**
Kick Off **SIMPSONS**
TAX **WBB** **Juliet**
POINT **HIGH SCHOOL**
EEEE **EEEE** **RED SQUARE**
Oak Wood **Romeodn**
JUNK FUNK **QUIZ SHOW**
Apollo **Good City**
anniz **SPURS** **american**
KRAMER **Koshgarian**
Notepad *My Words*
King William *Broken* *Henry*
Camelot *Rechtman* *Duncan*
CUSTAGLON **РУССКИЙ**
Lauren **UPPER WEST**
Micro **WEISS** **LICHTNER**
GLUMSY **RACKHAM**
GRUAMAN **Hot Shots**
Mushy **DRAIN** **ICED UP**
TRIBE **SCIENCE** **Cairo**
Mardi **Faktos** **ZALESKI**

Font Pack 8

Minster Mister **ANTIRUN**
Sans **SHILLIE**
BlancoBoy **SNOT** **cheese**
COMPUNI **Dashing**
defective **Neu** **PIFFY**
Middleton **Oldiez** **Piggy**
Mirisch **Odiez** **InSilicon**
ISADORA **WHITESPARK**
Kelvin **Always** **Jagger**
לדואמלה *Lawrance*
חאלשכח **Oregon** **Wef**
אנאחאח **MERRY**
Stroked **HotFOOD**
Stumpy **MORESCIENCE**
PMMXRMD **Rudelsberg**
PAPERCLIP **HERBONIE**
SCRIPTURE **Muniel** **Spoted**
Oliver **Serpentine**
LYNX **MESOZOI** **אנאחאח**
Home Away **SPRAYED**
LOOP DE LOOP **ZEBRA**

Low cost, good quality RISC OS Outline Fonts are now available in abundance from Skyfall. Why pay more, when our standard fonts will work with all font utilizing applications, such as Impression, Pendown, Draw and Ovation. Available on either 800k or 1600k discs, with graphical contents labels and installer files. Postage free for UK and Europe, elsewhere please add £0.50 per disc. Official orders are welcome.

Font Pack 4

PURE METAL **NEW YORK**
SALTER **METROPOLIA**
Chalk **FIRE** **WATER**
ELF JAZZ **JEVES** **WOOSTER**
BLACK ADDER II **Vampires**
GREEN **Rain** **BONES**
First Words *Royal* *Captain*
Birthday **LOMBARDIC**
Geswele **Paganina**
Creedmore **BENNY**
WING **BORSE** **Chopin**
Beatville **MANIA**
DINER **rabbit ears**
LEE **Medusa** **SPARK**
ANTIQU **Fundago**
DIGIT CAD **Muncho** **Madrid2**
Gexo **GALLOIS** **Lilith**
Anquillia **MAZAMA** **Flemish**
EMITION **STEMS** **Dickens**
CARACTIS **FOXTROT**
VIKING **RETS** **OOOO**

Font Pack 9

1968 *Snobby* **LEIGH**
ALGERIAL **IMPORTANT**
Wach **SOBS** **LIFFO**
Agreshire **LIVECITY**
BIKO **silky** **Lights**
BloriBlues **Locking**
Celtic **SNOWY** **MIRIDI**
Chicago **Striker** **Deat**
ClassicNib **IIIIII**
ClearCut **SPARKED** **Miami**
Columbus **Not Silcn**
CRYSTAL **NOUVEAU**
Diamonds **OMNIBUS**
Dobkin **Silver** **Question**
DraftTwo **Flowers**
Farlow **ROLLER**
FASTWRITE **SaintFontS**
ReLive **SoftWords** **Shaken**
WESTERN **WESTERN**
SOLIDTOOTH **WESTERN7**

Font Pack 5

Liberal *Casual* *Paradox*
Ink *Biot* *Arabian*
CareFree *Maidstone*
Skippy *Dragon* *Wick*
Phoenix *Pixie* *LINK* *SPICE*
REALWOOD **Wood Strip**
ZonyRentom **WEDDING**
ASSORTMENT **luembourg**
EIRE **NEON** **Polo**
Bad Boy **Sans Serif**
IMPRINT **RELIEF X**
Poor Type **DotMatrix**
Genoa **Mira** **Scout**
FOLDER **Nordic** **Fred**
Coliseo **Marquill**
DELTA **SHARKTOOTH**
三ノノ **OOOO**
FELTPEN **FeltMarker**
LOVE **PERCE** **Eye Brow**
Bulerworth **Harrington**
Cracked **Big Town**
Caraway **STUART** **Arctic**

Font Pack 10

MatchMaker **NightTime**
DarkAges *Royal* *Woods* *Sporty*
BT CLASSIC **SprayOn**
ST GENERATION **VeryFat**
IT **TOLETTA** **ToonTown**
ST MONITOR **Wezley**
ST Movie **TOMBSTONE**
ST Titles **WiseWords**
Draftsman *Dunkin* **Kanza**
ENVIRO **Stinky** **Dracula**
SS Open **Timon** **STRONGTHIN**
Eras *Stage* **FreeOpen**
Housey **Companion** **Thomas**
SWEETBOX **YearBook**
SWEETSHOP **SansSerif2**
OOOO **OOOO** **Tangled** **georgeOpen**
Lady *Lily* *ACTON* **DaisyChain**
LIMITS **TEAM SOLD**
SwirlWord **TEAM USA**
Roundary **TEAM WHITE**
Nineteen **DataFace**

Format	DD	HD
Discs per pack	4x800k	2x1600k
Single packs	£8	£6
Any 3 packs	£20	£16
Any 5 packs	£30	£22
All 10 packs	£52	£38

Skyfall
BOX 2220 BIRMINGHAM B43 7SF
TELEPHONE 0121 358 7078



Public Domain

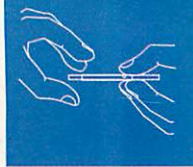

Beginners start here

OF the many letters I receive from readers every month, many are from beginners asking for advice on where to start off in the world of public domain software. Unfortunately, limited space on this page prevents me from including more information on a regular basis that would be useful for new users. Many have asked me to include more contact addresses for PD libraries, but using a quarter of the page to print the same information every month is a bit of a waste. Hopefully, I can remedy the situation with this one-off beginners' feature.

The large financial outlay of buying a first computer often prevents a new user from spending much on the actual software. This points many users to the public domain scene where relatively good programs can be picked up for the price of a disc. So assuming this scenario is sounding familiar, where do you start? Well, it obviously depends very much on what you bought your brand new machine for. Large, task-specific applications are not particularly common in PD collections, so asking a library for a CAD or word processing package, for example, will not always produce a good response.

With a few notable exceptions, the main area where PD software excels is in the domain of the utility. Utilities are small programs that enhance the desktop or simply make everyday computing that little bit easier. This is a great area for the user to start off with. There are literally

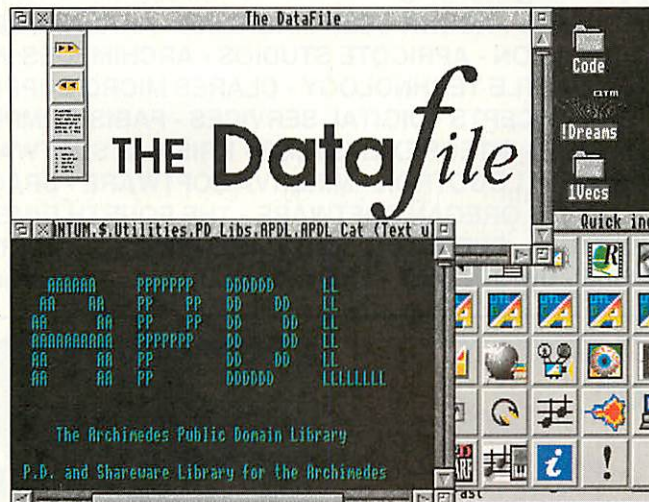

A plethora of PD and a wide range of libraries from which to get it

thousands of mini applications just waiting to be experimented with. It's a great learning process and after sorting through a pile of PD discs, you'll have plenty of utilities to add to your start-up boot sequence.

The very first stage should be to get hold of a good few PD library catalogue discs. Many people make the mistake of settling for the first library they try; don't do it! There's a good range of libraries out there and they all have some programs that the others don't. Most provide pretty fast services, but watch out for overcharging – when discs are sold for two pounds or more, the software authors aren't happy and you're getting ripped off as well.

If you're new to PD, don't be afraid to get involved on a more personal level. If you have any feedback or bug reports on a bit of PD, write to

the author. Most PD writers rely on responses from users for testing and for new ideas. This level of communication goes a long way in explaining the usefulness of so many PD programs, as they have been tailored specifically to the needs of the user.

Acorn machines have to be the best platform to learn to program on. You have everything you need to write software on a bare machine, and the RISC architecture is easy to code. So if you're experimenting with programming, the PD scene can be a testbed for your programs. If you are learning to program, get involved and put something back into the pool of software that is the public domain.

Here's a few recommended libraries to try. You'll find many more in adverts in this magazine, and in demos and programs written by the libraries themselves.

Disc mags

Unfortunately, due to time constraints, development of *PD Review* magazine – mentioned in a previous issue – has been delayed. The editor, Gareth Edmondson, hopes to produce an issue in the near future which will be in a revised format along the lines of a standard PD magazine.

Dizzy Wizard software also have plans for a similar disc magazine which they hope to produce after releasing the *Anarchy* demo they are currently working on. The team are particularly interested in recruiting more writers for the magazine before they release the first issue.

If you'd like to contribute to either of these productions – or indeed my own group's disc magazine, *New Dawn* – then please get in touch at the address below, and I'll pass your work on.

VI software

I was recently contacted by a representative from Buckinghamshire County Council's Visually Impaired Service, with regard to finding software suitable for visually impaired children. Aside from recommending some *Draw*-related materials, where the scaling and line thickness features of the software have been particularly useful, I have been unable to find any other specific PD programs that would be useful. If you know of any suitable programs or would like to get involved with writing some, please get in touch at the usual address.

Contacting me

You can contact the PD page by writing to me, Paul Wheatley, at *Acorn User*, IDG Media, Media House, Adlington Park, Macclesfield SK10 4NP or by e-mail to: quantum@digibank.demon.co.uk or online on the Arcade BBS.

Contact addresses

The Datafile PD	71 Anson Road, Locking, Weston-Super-Mare, Avon, BS24 7DQ. Tel: (01934) 823005
APDL	39 Knighton Park Road, London, SE26 5RN.
Five Star Marketing	4 Shepherd's Walk, Bushey, Herts, WD2 1LZ.
Arch Angel	PO Box 41, Exeter, Devon, EX4 3EN. Tel: (01392) 422750
HeadFirst PD	45 Cedar Street, Southport, PR8 6NQ.

Desktop+

DEVELOPMENT of the popular Desktop+ application, featured on *Acorn User's* subscription disc, has recently been taken over from coder Michael Rozdoba by Benoit Gilon who intends to continue development work on this useful application. Watch this space for further developments.



Fireworkz Professional finally available

THE RISC OS version of *Fireworkz Pro* is finally ready after its debut at the Acorn World Show last October. Writing this in early January, only days ahead of the BETT show, Colton Software was finishing its bug-testing on the new integrated package.

In the PC marketplace, integrated packages have the distinctive feeling of being a freebie. Indeed, many manufacturers include the likes of *ClarisWorks* with their machines as standard. *Fireworkz Pro* is quite dissimilar in most important respects. It doesn't come with pathetic painting and drawing modules, nor does it have a shell. In *Pro*, as the above screenshot shows, there is full integration, meaning one can have word processing, spreadsheeting and databasing all on the same page.

According to Colton Software, the spreadsheet part – *Resultz* – is as powerful as Microsoft's *Excel*. Nevertheless, I doubt most people will ever require these sort of facilities for general office use.

I know many people use databases for all sorts of admirable tasks, but I've always held the view that their main function is to amass contact information. When looking for someone's fax number, it's so tedious to have to search through a stack of hundreds of invoices or letters. This is where a database comes in handy. The next step on from this is a dedicated contact manager like in *Enterprise*: Though if you're larger than a

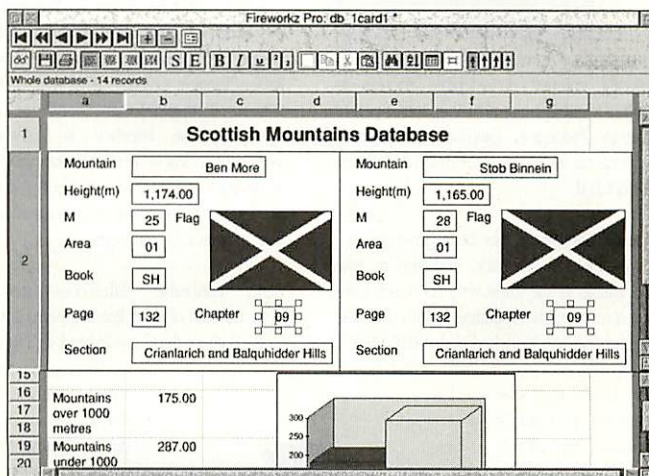

In *Fireworkz Pro* you can 'split' the screen as above.

partnership, it is hardly satisfactory to let all your staff use *Enterprise* (an accounting suite) to find out telephone numbers.

The database part of *Pro* uses Iota Software's database engine. This allows databases to be transferred between *Pro* and *DataPower*. The importance of this is that *DataPower* is supposed – though this is contentious – to be top rank among databases on the Acorn platform, meaning that many people will already have the package. This intrigues me as a number of Acorn-related companies seem to be arriving at such deals (like Apricote Studios and Silicon Vision). Nonetheless, I expect the competition will continue to hot up.

Databases can be produced in either a card or spreadsheet layout, with the capability to switch between the two at a later date. Fields can be re-sized

and re-positioned at any time with the mouse.

The word processor element is basically a standard, everyday sort of program that many PC-based offices use. Anyone using the likes of *First Word Plus* should upgrade immediately, though many people will demand a desktop publishing package.

On paper and at a demonstration of the program last October, it seems to be a very capable and professional product (hence its name). As stated by Colton Software, *Pro* was delayed because Colton wanted to release a quality and tested package rather than one which was rushed and bug-ridden.

Existing customers should have been contacted and offered upgrades. Otherwise it costs £149 + VAT. *Recordz*, which is the database by itself, retails at £99 + VAT. Consequently it is more cost-efficient to purchase the three 'modules' as *Fireworkz Pro* rather than individually.

Colton Software
Tel: (01223) 311881
Fax: (01223) 312010

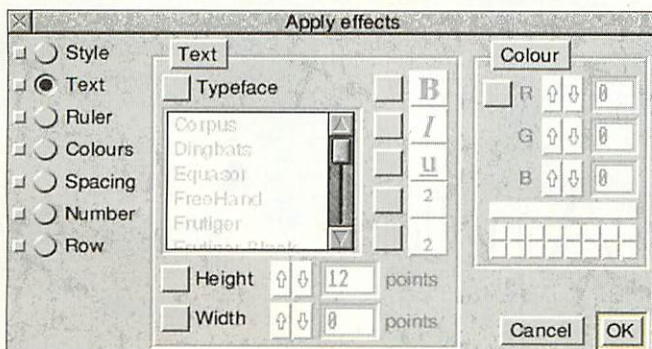

The effects dialogue box in Colton's Z-range of software. If you want to change an effect, why do you have to click on an option icon to stop it being 'greyed out'?

Bargain software

I have been asked by a number of people to suggest a cut-price spreadsheet for occasional use. Contex Computing markets such a program for the Archimedes at only £16 + VAT. While this isn't multitasking, just look at its price.

Furthermore, Contex sells a cheap home finances package and a touch-typing tutor. If you purchase the finances program, you can upgrade later (or rather downgrade) to the IBM clone version and retain all your existing information.

Contex Computing:
(01234) 838347

Apricote's lottery

In response to a customer's jest, Quentin Pain, partner in Apricote Studios, has written a multitasking National Lottery number picker. Called *Aprilot*, it is supposed to eliminate the hassle from choosing lottery numbers. It may be published on a forthcoming Acorn User cover disc...

Lease-a-micro

You invest in an A5000 and a month later it's been replaced by the newfangled Risc PC. Sounds familiar? Senlac Computing is offering Risc PC leasing from under £45 per month over three years. This is subject to status and only applies to business users.

Company cars

Sincere apologies to ACP. I seem to have confused its *PayMaster* program with Silicon Vision's *Payroll Manager*. Last month I said that *PayMaster* can't calculate tax concerning company cars which in fact – unlike *Payroll Manager* – it does. We'll be taking a much closer look at *PayMaster* and *Payroll Manager* in a future issue.

Contacting me

You can contact the Business page by writing to me, Alex Singleton, at Acorn User, IDG Media, Media House, Adlington Park, Macclesfield SK10 4NP, or by e-mail to: alex@acornusr.demon.co.uk.



Rephorm takes two sprites of any size and allows a morph to be generated between them. You simply identify a number of key control points on the start sprite and reposition them to similar places on the end sprite. Rephorm calculates so quickly that the effects of repositioning control points can be seen in real time as you drag them! All calculations are performed in the background so Rephorm never stops the machine from multitasking. The user interface has been widely acclaimed for both its simplicity and its versatility. The morph can be displayed on screen, saved to disc as either an Ace Film or an Acorn Replay file, or individual frames or groups of frames may be saved as sprites.

Since its launch last year, several extra features have been implemented. Chief among these is Object linking and embedding (OLE). Control-double-clicking on any sprite within Rephorm will automatically transfer it into !Paint (or another painting package) for editing. Saving the edited sprite from !Paint will instantly transfer the sprite back into Rephorm, which will then recalculate the effects of the change.

Rephorm has always supported the 16 and 32 bit sprite file formats for the new Risc PC, but a new utility, !UnClear, allows the now obsolete 'ClearFiles' to be converted into sprites for use with Rephorm. Another utility, !Splitter, will split a SpriteFile containing a number of sprites into individual sprites.

As well as being able to produce morphs and distortions of images, Rephorm can also produce video style special effects such as fades and wipes. These are useful for those people creating and editing Acorn Replay films, providing interesting ways to join two clips together.

Rephorm costs £50
Upgrades to version 1.04 £15

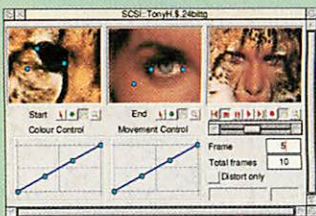

Rephorm

OakPCB II

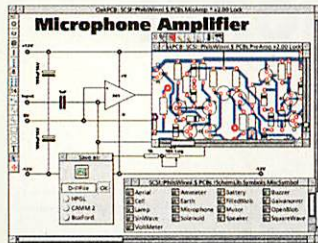

Having enjoyed considerable success as both a stand alone application, and as part of Design Processor, OakPCB has recently undergone its first major revision to become OakPCB II.

The changes made have been generated as a result of user feedback, and also to take advantage of the improvements which have been made to the operating system since the application was launched under RISC OS 2.

As ever, the user interface to OakPCB is based very closely on !Draw, and users familiar with that package will find no difficulty in getting to grips with the business of creating and editing both schematic diagrams and printed circuit board layouts. OakPCB can handle anything from simple single layer boards all the way up to 4 layer. Comprehensive (and extendable) libraries are provided for both PCB and schematic work.

By default, OakPCB aligns tracks in multiples of 45°, although this feature can now be turned off to allow tracks to be placed at any angle if required. Visual feedback is given whilst in this mode and when editing tracks, so that the tracks change colour when they are aligned at 45° intervals.

A new utility called PCBDrill is supplied which allows circuit boards to be drilled automatically on the Roland CAMM 2 and CAMM 3, and also on Boxford milling machines. Oak PCB II runs on all RISC OS computers including the new Risc PC. It outputs to Plotters and RISC OS printer drivers via Draw Print & Plot (supplied).

OakPCB II costs £70
Upgrades cost £35

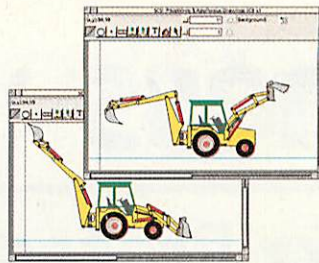
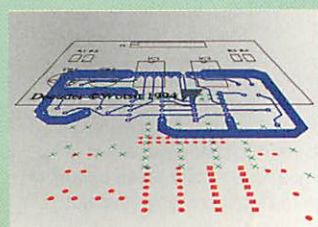

Apollonius PDT is a fully parametric 2D CAD environment. However the user interface differs considerably from conventional wisdom. Normally CAD packages are cluttered with an abundance of methods for drawing each type of object. For example the circle tool will have variants such as Centre/Circumference, Centre/Radius, Radius/Tangent to 2 objects, Three point etc. With Apollonius PDT there is only one Circle tool, but the interface is sufficiently intelligent to know what type of circle you are trying to build by which objects you click on. Indeed the number of options is larger than in most CAD packages.

Other noticeable differences are the apparent lack of short line segments and arc tools. Both of these are instead replaced by an 'intelligent pencil' which allows the draughtsperson to draw round the relevant parts of construction lines in one quick operation.

Being parametric, the package allows the designer to answer 'what if' questions very rapidly. The whole drawing will be recalculated and redrawn as you change the positions or sizes of key objects, or even the geometrical relationships between them, by simply dragging any item around the screen.

Altogether, Apollonius represents a radical new way of doing CAD. It makes it possible to create clear, flexible, accurate designs, with the minimum of training. The amateur user benefits from the amazing ease of use, while the professional benefits by its unrivalled parametric power.

Apollonius PDT costs £150
Upgrades from WorraCAD and Oak PDT £75

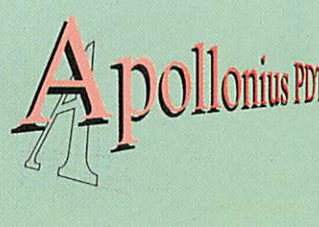
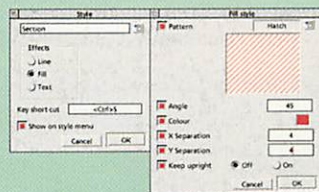

genesis

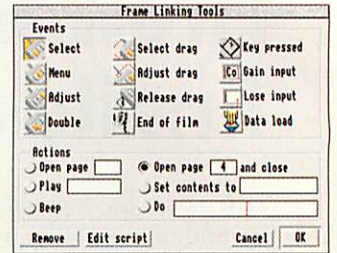

Genesis Professional and Project are the successors to Genesis II and Genesis Plus and feature greater power, speed, and ease of use. The Genesis menu structure has been simplified by using dialogue boxes to alter the style of frames and pages. Master pages can now be created and added to a library. Application creation and editing has been eased by the introduction of 'Object Linking and Embedding'.

New data types have been incorporated into Genesis, which now supports Artworks, Replay, Windows .BMP and .WAV files. Predefined control buttons can be added to Euclid, Film, Replay and Sound frames. A 24 bit colour model is used throughout and Genesis can handle the new 15 and 24 bit Sprites. The speed at which Genesis pages load has also been increased significantly.

Genesis Professional provides support for Lasersession players and for CD. Its powerful Script language has been extended with a host of new keywords and now supports global variables.

Genesis Project is a friendly multimedia authoring system which provides sufficient power to satisfy the everyday needs of most users. Applications authored using Genesis Project are, of course, fully compatible with Genesis Professional so that they can be used as the basis for more complex work. Genesis Project differs from Professional in two significant ways. There is no access to the script programming language, and the overall program structure is simplified with fewer menu options and a reduced range of linking tools. This makes Genesis Project less daunting to the novice user than its big brother, whilst allowing progression to Genesis Professional at a later date.

Upgrades are available from all previous versions of Genesis (including Learning Curve), telephone for details.

Genesis Professional costs £120
Genesis Project costs £50

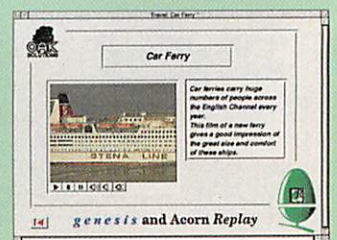

Into Oblivion

THE latest product from the Hampshire Microtechnology Centre is *Oblivion* by Chas Duckhouse, and is unlike almost any other program I've seen.

Oblivion is a whole class activity for upper Key Stage 2 to lower Key Stage 3. The teacher divides the class into groups and gives each a name. Students then go to the computer, enter their group name and receive instructions and a codeword to get onto the next level. The group then goes away and completes the problem, which will require skills from a range of subjects including technology and mathematics. The eagle-eyed among you will

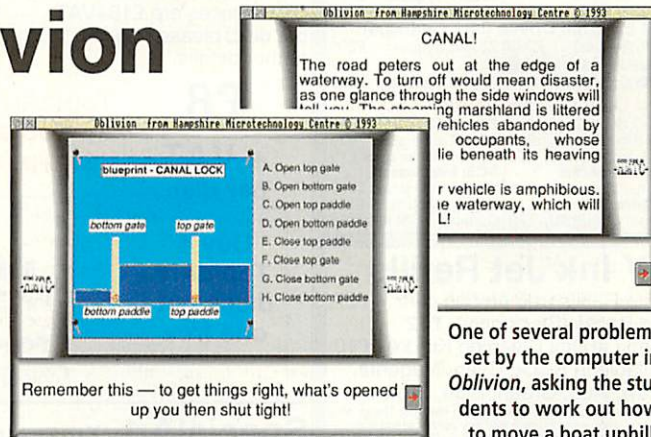

recognise the codewords as being 4Mation products and this is partly due to the fact that it was produced using 4Mation's authoring program.

Oblivion is a clever idea but if you decide to try it, you will have to prepare some materials for the groups. The manual

gives some ideas about the implementation and depth to which the teacher(s) can go. For primary teachers who are getting stuck for technology ideas, this is a must.

Hampshire
Microtechnology Centre
Tel: (01705) 378266

One of several problems set by the computer in *Oblivion*, asking the students to work out how to move a boat uphill.

Home help from PIN

THE Parents Information Network is a national independent organisation of and for parents and educators who are either interested in, or concerned about children's experiences of Information Technology. According to PIN, many parents do not understand the way in which their children use computers at school and consequently are not able to offer very much assistance at home.

The group was founded by

Pauline Cameron who is an inspector, teacher, governor and parent. 'The educational potential offered through technology in homes and local communities that can be used by children with parents is awesome,' says Pauline. 'Unless parents are enabled to grasp this opportunity, and the potential it offers to us, we cannot help our children fully.'

There is a regular newsletter called *Parent Power* and

schemes are afoot to provide opportunities for parents to use Information Technology with their children in schools and libraries, and even in high street stores.

You can join PIN by writing to Red Hatch House, St John's Road, Ascot, SL5 7NH. In the meantime, have another read through the *Computing for the Family* supplements which were supplied with the December 1994 and January 1995 issues of *Acorn User*.

Full Logo in a window

LONGMAN Logotron's version of *Logo* has long been regarded as the version for Acorn computers. Its only drawback is that it isn't multitasking. The latest version called *WinLogo* now runs from the desktop and, like the previous version, is the full implementation of the language.

The new version is generally much easier to use in all areas — except one. In a stroke of pure genius, the programmer has organised it so that the Delete key deletes the character to the right of the caret and not the left as in every other text program. This has caused so much

confusion among the students that I've all but abandoned it until a corrected version is available.

I spoke to Longman who first tried to tell me it is a RISC OS problem, but eventually agreed it's a *WinLogo* problem. Apparently this use of the Delete key is common practice on a PC — the source of the original program. If anyone does fancy an upgrade, Longman can provide one. A site licence upgrade is

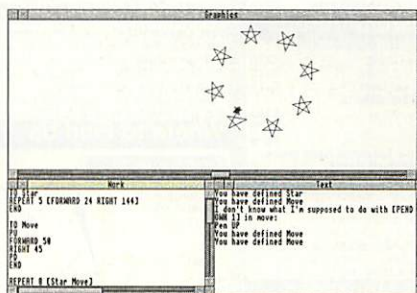

Press Delete in Longman's *Logo* and you'll lose the 'T' not the 'H'.

just £69, the cost of the stand alone version.

Longman Logotron
Tel: (01223) 425558

Resources for all

NCET Publications and The Geographical Association have just released a resource for teachers called *Shopping and Traffic*. The pack includes a disc for Acorn, PC and Apple containing datafiles and spreadsheets for popular software. In the case of the Acorn disc, there are files for *Pinpoint* and *Eureka*, and the data is also supplied in CSV format so that it can be imported into most database and spreadsheet programs. The accompanying booklet provides some detailed notes on how to use the material with a class.

NCET Publications
Tel: (01203) 416994

Oh no, not more National Curriculum!

Afraid so! The latest version of the National Curriculum is greatly simplified and recording students' work should be easier as there are now fewer targets.

On the cover disc is a *Draw* file called *ITtargets* giving all the targets on a single piece of paper (as it appeared in the January issue). Add to this a place to write a name and the sheet could form the basis of a report. The text has been entered as text areas, so can be easily extracted and, once the control codes have been deleted, could be dropped into a database or word processor. *KS1-4* is such a file for use in either *DataPower* or *Advance*.

Contacting me

You can contact the Education column by writing to me, Geoff Preston at *Acorn User*, IDG Media, Media House, Adlington Park, Macclesfield SK10 4NP or by e-mail to: gpreston@arcade.demon.co.uk.

CD-ROM

All the following CD-ROM drives are PhotoCD compatible and include a driver for CDFS =>2.20

Internal Drives		
XM-3401B (Caddy)	330kb/s, 200ms	£235
XM-3501B (Caddy)	600kb/s, 135ms	£299
Suitable for RiscPC. SCSI interface not included.		
Cumana CD300i IDE	300kb/s, 300ms	£199
Cumana CD300ia IDE		£249
External SCSI CD-ROM Drives		
Panasonic (Tray)	300kb/s, 300ms	£229
XM-3401B (Caddy)	330kb/s, 200ms	£300
XM-3501B (Caddy)	600kb/s, 135ms	£379
SCSI interface not included. Add extra £25 for A3000.		
SCSI cards		
Morley uncached SCSI card		£130
Morley cached SCSI card		£170
Cumana SCSI II card		£169

The above cards are suitable for A300, A400, A3000 (Ext), A540, A5000 and RiscPC. For others see MultiPodules. Add £25+VAT to Cumana SCSI II card for external cable.



Hard Discs

IDE Bare Drives		SCSI Bare Drives	
170Mb 14ms	£100	270Mb 12ms	£139
270Mb 14ms	£139	540Mb 12ms	£199
420Mb 14ms	£169	730Mb 12ms	£249
540Mb 12ms	£189	1Gb 12ms	£349
Above are 3 1/2" bare drives only. Please add the relevant accessories from below. Drives are Comor or Quantum. For A3000/A3010 hard discs see Hard Card section below.			
Squest Removable Hard Drives			
IDE Bare Drives		SCSI Bare Drives	
105Mb Squest	£159	105Mb Squest	£189
270Mb Squest	£289	270Mb Squest	£289
SCSI External Drives (Incl. Cartridge)			
105Mb Squest	£289	270Mb Squest	£299
Squest Cartridges			
105Mb Cartridge	£45	270Mb Cartridge	£55
Hard Disc Interfaces/Accessories			
50-50 SCSI Cable	£12	25-50 SCSI Cable	£15
SCSI II-50 Cable	£25	SCSI Terminator	£10
5 1/4-3 1/2 open adapt	£10	5 1/4-3 1/2 HD adaptor	£15
IDE Accessories			
IDE interface	£79	Morley Uncached	£130
2nd Drive Kit	£15	Morley Cached	£170
External case/PSU	£79	Cumana SCSI II	£169



TopicArt

Single disc clipart containing approx. 50 high quality draw format clip art images, each on a single subject. Comes with mono reference sheet. 12 subjects are available now. Please specify when ordering. Site licences are £16+VAT per disc, please ring for further details.



TopicArt9 - Dinosaurs

£8 + VAT per disc

TopicArt catalogue now available. £1.50 Inc VAT & p+p (cheques only)

Buy 4 TopicArt discs get one free not incl SpecialArt



TopicArt12 - AnimalsGB

- Subjects avail.
- 1 - General
 - 2 - Transport
 - 3 - Costumes
 - 4 - Entertainment
 - 5 - Bugs 2 Slugs
 - 6 - Road Signs
 - 7 - Sports Equip
 - 8 - Sports Figures
 - 9 - Dinosaurs
 - 10 - Symbols
 - 11 - Tools
 - 12 - AnimalsGB



TopicArt4 Entertainment

QuickTile v1.02 £25+VAT

Up until now it has only been possible to print posters from Draw & Sprite files. Now with QuickTile you can create posters from ANY RISCOS application, including Impression. Simply enter the size of poster required & select PRINT from the application! QuickTile does the rest, printing each tile with crop marks and tile references. RiscPC compatible. Requires RISCOS 3.10 or later. Return Disc with SAE for upgrade. Upgrade from Tiler for £15+VAT.



DIY Ink Jet Refills

Single Refills (req an orig cart.) £7
Twin Refills (Black only) £12
125ml / 400ml Cleaning Kit £4 / £10
Available in Black, Cyan, Magenta, Yellow, Red, Green, Blue, Brown
Please specify colour(s) required when ordering. These do-it-yourself refills can be used with any printer where the head and ink reservoir are combined, i.e. DJ-500, BJ10/200. Please do not send empty cartridges. Please note that colour quality may not be 100% from a black cartridge refilled with another colour. We cannot guarantee against dried up empty cartridges and/or blocked nozzles.

- QuickSound** £10
Load, play, convert & resave Amadeus, Tracker and raw data sound samples. Apply special effects including Reverse, Echo, Max Vol, aller replay rate and resample frequency. Convert samples into modules for use with the RISCOS sound system. Create stand alone Utility mod's.
- QuickShow** £10
Slide show presentation and video tiling package. Create sequences of frames containing text of any colour with drop shadows, outline shadows and ribbon boxes using the RISCOS fonts. Sprites can also be included in frames, positioned and resized as necessary. Screens can be linked together with the sequencer with fades in and out.

SpecialArt (Xmas or Signs) £20+VAT (each)

Special editions of TopicArt consisting of a minimum of 4 discs full of clipart



RISCPC
All RiscPC's include 1yr on-site maintenance. Low finance available. The following prices do not apply to finance, ring for details.
We operate Acorn Assist for teachers & academics. All RISCPC systems are now in stock.

2MHD210 + AKF60	£1199
2MHD210 + AKF85	£1575
5MHD210 + AKF60	£1299
5MHD210 + AKF85	£1675
9MHD420 + AKF60	£1599
9MHD420 + AKF85	£1975

Add following for CD-ROM
Cumana CD300i (IDE) £199
Toshiba x2.2 speed (SCSI) £330
Toshiba x4 speed (SCSI) £390
Above SCSI CD-ROM are caddy loading & the prices include uncached SCSI card. The above prices only apply when purchased with a RiscPC system.

RiscPC Upgrades

4Mb SIMM RAM	£140
8Mb SIMM RAM	£230
16Mb SIMM RAM	£375
32Mb SIMM RAM	£680
1Mb VRAM (Acorn)	£129
2Mb VRAM (other)	£169
1 to 2Mb VRAM Upgrade (exchange)	£109
486 PC Upgrade (available - Oct 94)	£399
MS-DOS 6.2 & Windows 3.11	£99
2nd Slice Case Upgrade	£99
Acorn Access for RiscPC	£119
Ethernet Interface Card	£99

A Series Computers

A3010 Action Pack 1Mb RAM	£254
A3010 Learning Curve 2Mb RAM	£339
A3010 Early Years 2Mb RAM	£339
Add £170 to A3010's for AKF52 Monitor.	
Free Action Pack with A3010 LC/Early yrs.	
A3020 2MFD/DAKF52 MultiScan System	£569
A3020 2MHD105/AKF52 MultiScan Sys	£849
A3020 2MHD105/AKF52 MultiScan Sys	£879
Add £55 for AKF50 Monitor (not A3010)	

Software Packs

Learning Curve Advance & PCSoft	£42
Early Years Talking StartWrite, Paint Pot	£42
Flossy the Frog, Mouse in Holland, etc.	£99
Home Office	£85
EasiWriter2, DataPower, PipeDream4, PCSoft above are ONLY available with a system.	

Monitors

Acorn AKF52 14" 0.39dp MultiScan	£250
Acorn AKF50 14" 0.28dp MultiScan	£300
Acorn AKF60 14" 0.28dp MultiScan	£320
Acorn AKF65 17" 0.28dp MultiScan	£649
Certain computers will require an adaptor	£12

Portable Computers

Pocket Book II (256k)	£227
Pocket Book II (512k)	£275
Pision 3a (512k)	£299
A-Link (requires RISCOS 3.1)	£42
PC Link (for IBM PC compatibles)	£60
Parallel Link for Pocket Bk or Pision 3/3a	£26
P Book/Pision 3/3a Mains Adaptor	£60
128k RAM SSD	£15
256k Flash SSD	£47
512k Flash SSD	£77
A4 Portable A4MHD60 with PC Emulator	£1599

Hardware Upgrades

486sx25MHz Bare PC Card	£357
486SLC50MHz Bare PC Card	£434
486sx25MHz PC Card 4Mb RAM	£489
486SLC50MHz PC Card 4Mb RAM	£525
ARM3 (25MHz), Inc FPA socket	£169
Colour Card Gold (CC)	£199
Eagle M2 Multi-media Card (CC)	£28
Joystick Interface (all m/c's)	£28
Logitech Mousy (Acorn)	£25
Midi Max Card (CC)	£68
Movie Magic (CC)	£249
Powerpad (dual) (Gamesware)	£33
Scart - 15pin Monitor/RGBTV cable	£12
Serial Upgrade for A3000 (Acorn)	£19
Stereo Speakers 25W (mains powered)	£39
Sportster 14k4 Fax/Modem Bundle	£225
Sportster 28k8 Fax/Modem Bundle	£299
The above modem bundles include a cable, - ArcTerm7 and ArcFax.	
TV Tuner (CC)	£88
TV Tuner with TeleText (CC)	£157
User/Midi u/g (A3000/A4000) Ex-Demo	£130

Memory Upgrades

A3000 1-2Mb	£55	A3010 1-4Mb	£145
A3000 2-4Mb	£90	A3020/A4k 2-4Mb	£99
A3000 1-4Mb	£129	A5000 2-4Mb	£89
A3010 1-2Mb	£45	A5000 8Mb	£259
A3010 2-4Mb	£105	A3/400 8Mb	£249

Hard Cards/Multi-Pods

A3010 HCS Hard Disc Multi-Podule	£225
80Mb + User Port + 2 Slots	£325
160Mb + User Port + 2 Slots	£415
250Mb + User Port + 2 Slots	£475
A3000 Internal IDE Hardcards	
80Mb + User Port	£185
160Mb + User Port	£275
250Mb + User Port	£415

Scanners/Digitisers

ScanLight Video 256 A5000/RiscPC	£199
ScanLight Video 256 A3000/A4000	£205
Canon IX-4015 Colour SCSI Scanner	£620
Above includes ITWAIN/ImageMaster & Cabl	
Vision24 Colour Digitiser Int 296/Ext 109	
Hi-Vision24 Digitiser A5000 Int 134/Ext 149	

RiscOS 3.1 Upgrades

A300/A440 Series (inc carrier board)	£97.88
A400/1, A3000, A540 Series (In stock)	£75.75
Bulk Pack of ten upgrades	£339.00
Please add £4 (Inc VAT) carriage to RiscOS	

Printers (Include Cable)

Canon BJ-200 (360dpi)	£210
Canon BJ-230 (360dpi)	£280
Canon BJ-600 Colour (360dpi)	£360
Canon BJC-4000 Colour (360dpi)	£320
Epson Stylus Colour Printer (720dpi)	£360
HP LaserJet 4L 4ppm (300dpi)	£429
HP LaserJet 4P 4ppm (600dpi)	£629

Printer Consumables

BJ-100 Ink Cartridge (BC-01)	£17
BJ-200 Ink Cartridge (BC-02)	£18
BJ-300 Ink Cartridge (BJ-642)	£16
BJ-600 Black Cartridge (BJ-201)	£7
BJ-600 Colour Cartridge (BJ-201)	£8
BJC-4000 Black Cartridge (BCI-21BK)	£9
BJC-4000 Colour Cartridge (BCI-21C)	£17
BJC-4000 Fast Black Cartridge (BC-20)	£28
BJ-800 Black Cartridge (BJ-643)	£16
BJ-800 Colour Cartridge (BJ-643)	£20
DeskJet500 Mono/Colour Cartridge	£21/£23
EP-L Toner (LBP-4/5 HP LJ11)	£25
HP 92274A Toner (HP LJ4L)	£59
JP-151 Ink Cartridge (Acorn)	£22
Swift24 Mono/Colour Ribbon	£7/£15

Books (No VAT)

ACORN RISCOS PRM's	£99.00
Add £7 (Inc VAT) carriage for PRM's	
Acorn 5th PRM covering RISCOS3.5	£29.00
Acorn BBC Basic VI Guide	£10.00
ArtWorks Made Easy (Dabs)	£14.95
Begin's Guide to WIMP Prog	£12.95
DTP on the Archimedes (Sigma)	£12.95
First steps in prog RISCOS (Sigma)	£14.95
Game Maker's Manual (Sigma)	£14.95
RISCOS 3 First Steps (Dabs)	£14.95

Terms

EC residents add 17.5% VAT to all prices except books. Carriage free in UK (excluding remote areas) (except books), elsewhere at cost. Orders MUST be accompanied by a phone number. Prices and spec's subject to change without notification. Goods subject to availability. Goods not offered on trial basis. Restocking fee on non-faulty returns. Official orders welcome from educational institutes, chq with order under £30. E&OE.

Where to Find Us

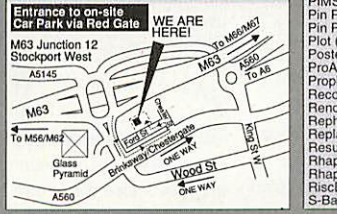

Applications

Advance 2Mb (Acorn)	£95
Advantage (Longman)	£46
Ancestry (Minerva)	£34
ArcFax (David Pilling)	£28
ArcTerm7 (Serial Port)	£58
Artisan 2 (Clares)	£42
ArtWorks (CC)	£125
AudioWorks (CC)	£45
AULM Level 4 (Acorn)	£366
C/C+ (Acorn) NEW!	£199
Calc News (Ling)	£135
CADET (Minerva)	£79
Card Shop (Clares)	£19
Chameleon 2 (4Matton)	£33
ClipArt CD 1 (CC)	£19
ClipArt CD 2 (CC)	£19
Comp. Animator (IOTA)	£99
Compression (CC)	£34
DataPower (IOTA)	£123
Desktop C v4 (Acorn)	£120
Desktop Thesaurus (BB)	£19
Digi. Symphony (Oregon)	£38
Easy C (Beebug)	£55
Easy C++ (Beebug)	£79
Eureka v2 (Longman)	£93
FireWorkX (Colton)	£95
FireWorkX Pro (Colton)	£Call
Font FX (DataStore)	£10
Genesis Professional	£110
Glimpse (Sherston)	£110
Graphics Loaders (CC)	£42
Hard Disc Comp. (BB)	£45
Hatchback (4Matton)	£28
Hearsay II (Beebug)	£75
Home Accounts (Minerv)	£32
Illusionist (Clares)	£41
Image Outliner (IOTA)	£46
Impression Publisher	£125
Impression Publisher+	£289
Impression Style (CC)	£79
MacFS (CC)	£85
MasterFile II (Beebug)	£47
Maggie (Longman)	£50
MasterFile III (Beebug)	£45
Morpheus (Oregon)	£28
Night Sky (Clares)	£63
Notate (Longman)	£54
Ovation (Beebug)	£79
PenDown Plus (Ling)	£67
Personal Accounts (Apr)	£99
PhotoDesk (Spacetech)	£157
PhotoTouch (Oregon)	£68
PIMS (Longman)	£339
Pin Point Junior (Ling)	£25
Pin Point 2 (Logotron)	£79
Plot (Clares)	£63
Poster (Matton)	£74
ProFantasy 2 (Clares)	£102
Elite Gold Edition (Hyb)	£28
Enter the Realm 2Mb	£13
E-Type 2 Comp. (4D)	£13
E-Type 2 (4D)	£24
Fit & Ice (Renegade)	£20
Hatchback (US Gold)	£22
FIT (TBA)	£18
FIT (TBA)	£18
GODS (Krisalis)	£22
Guile (Dreamp)	£10
Haunted House 2Mb	£18
Heimdal (Krisalis) 2Mb	£13
Herc Quest (Krisalis)	£22
Holed Out Compendium	£13
Ixon (Gamesware)	£16
S-BASE2 Personal (Ling)	£99

Applics (Cont'd)

S-Base 2 Developer	£189
S-Base 2 Developer+	£345
Serenade (Clares)	£34
Schema 2 (Clares)	£95
ShareFX (Datastore)	£130
Shares (Apricot)	£30
Sleuth (Beebug)	£42
Snippet (4Matton)	£31
SparkFS (Pilling)	£21
Speechi (Super)	£19
Squirrel 2 (Digi Serv)	£120
Tiler (Clares)	£114
Touch Type (IOTA)	£38
TurboDriver BJ (CC)	£42
TurboDriver HP (CC)	£42
TurboDriver Epson (CC)	£42
Tween (Ace)	£28
TypeStudio (Beebug)	£43
Vector (4Matton)	£73
Worra CAD (Oak)	£85
WordWorks (CC)	£32
Word (Colton)	£55

Games

Air Supervise (Sup)	£17
Arcturus (Oregon)	£20
Axis (TBA)	£21
BattleChess (Krisalis)	£22
Speedball 2 (Krisalis)	£19
Spheres of Chaos (Matn)	£19
Starfighter 3000 (Fednet)	£23
Stunt Racer 2000 (4D)	£24
St Racer Xtra Tracks	£17
SWIV (Krisalis)	£20
Tank Machine (4D)	£18
Virtual Golf (4D) 2Mb	£14
Virtual Golf Augusta Cse	£13
Wolfenstein 3D (Powers)	£23
Xenon 2 (Gamesware)	£19

Educational

Portables

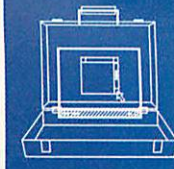

Portable PD

THE world of Pocket Book PD is thriving. The Datafile has just released its first collection of Pocket Book PD software and the quality and range of what is available is amazing. There are currently eight discs in the set, selling at £1.35 per disc including VAT. Described below are, in my opinion, some of the best software packages from the collection, but don't blame me if I've missed out any equally good packages – it would take a magazine the size of *Acorn User* to describe every piece of software in detail.

If you've ever wished your Pocket Book II was also a Game Boy, then this collection is ideal for you. Included in the collection are classic games such as *Tetris*, *Pipe 3a* (a *Pipemania* equivalent), *Columns* and *Connect 4* as well as some more modern games including *Blitz*, *Fairway* (an excellent golf game) and *Shuttle*. All these games are highly recommended but my personal favourites are *Tetris* and *Columns* by S Godfrey and *Fairway* written by Steve Litchfield. All these have brilliant gameplay and great graphics, especially *Fairway*, whose graphics have to be seen to be believed.

As with all PD collections, the Pocket Book collection contains a wide range of utilities that will do anything from compressing files and sorting databases to checking the status of your battery and assisting in moving between programs. Of particular note in this category is Psion's own Series 3a utilities. This is an excellent program which will

allow you to sort your database, sort and search your files, insert extra fields into databases, copy easily between directories and edit files in hexadecimal format. As well as this it is also able to display your disc in a Windows-style directory tree. Excellent.

Also included in the collection are a number of very useful applications. *Sheet* by Andrew Greasley is a spreadsheet designed for the Psion 3 user, because until recently the Psion 3 spreadsheet was a costly extra. It offers most of the features found in the Psion/Acorn equivalent apart from graphing, it's easy to use and it's shareware – what more can I say?

In the collection there are a large number of accounts packages for the Psion 3a/Pocket Book II. My personal favourite is *Accounts* by Gareth Evans. This offers a multitude of features including password protection, standing orders, multiple accounts, money transfers and is an absolute doddle to use.

Worth a mention are the programs *Periodic* and *Barcoder* – both these programs are designed for the Pocket Book II/Psion 3a. *Periodic* by Anthony Kucernak is an excellent program for all chemistry students out there. As well as providing a periodic table database containing information on each element such as atomic radii, melting point and so on, it is also able to work out molecular masses just by entering in the chemical formula – a real boon. *Barcoder* by ACB software is an interesting little program that allows you to

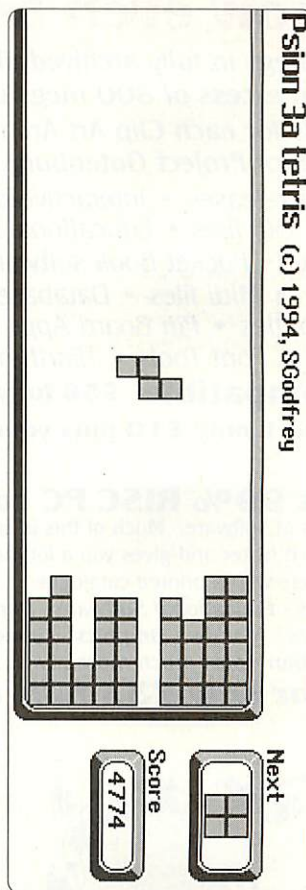

The original and still the best – *Tetris* on your Pocket Book II.

create and print out barcodes via the Parallel link. Admittedly it doesn't do much else, but if you have a need to print out barcodes you can't go far wrong with this one.

This article shows the PD world for the Pocket Book is very much alive and kicking with many excellent applications. In this short space I have barely touched the surface of what is included in the collection, but if you have a Pocket Book II or Psion 3a this collection is well worth getting.

The Datafile
Tel: (01934) 823005

Speaking Pocket Books

I recently received a letter from the Welsh society for the blind asking if any software is available for the Pocket Book II that would speak as you type. Although software is available that speaks numbers as you type them, I am not aware of any software that speaks letters. If, however, anyone does know of such a piece of software or fancies writing one, please let me know at the usual *Acorn User* address.

A portable request

Having recently become interested in the wonderful world of comms – and the art of running up huge phone bills – it was while I was logged on to the Digital Databank that I received a request for Pocket Book software to be uploaded onto the BBS.

Is there anybody out there that has any Pocket Book software that could be uploaded? If they have, I am sure the Digital Databank would be very grateful to receive it.

Digital Databank
Tel: (01707) 329306

Is it possible?

The Pocket Book II's *Schedule* is an excellent program apart from one thing: the need to buy a parallel link in order to print out from it. Wouldn't it be nice if someone could write a program that allows you to export the data as a text file which could then be A-linked across to the Archimedes and printed out from there? Does anyone know of such a program, or would consider writing one?

Contacting me

You can contact the Portables column by writing to me, Mark Taylor at *Acorn User*, IDG Media, Media House, Adlington Park, Macclesfield SK10 4NP or by e-mail to: markt@acornusr.demon.co.uk.

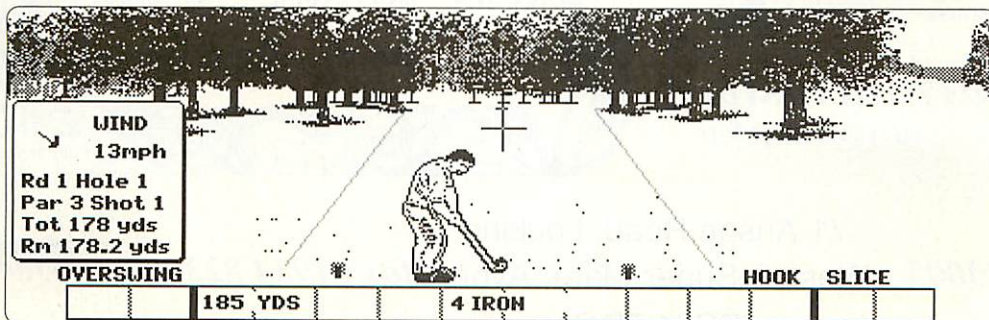

Score a birdie with the excellent *Fairway*.

Look THE *Datafile* CDs



Our first CD ROM is now even better

- 475megs in fully archived files
 - That's in excess of 800 megs un-archived
 - Thumbnails for each Clip Art Archive
 - The full version of Project Gutenberg. March 94
 - All the latest PD & shareware releases • Interactive database
 - Fractals • Games Demos • GIF files • Educational software
 - Clip Art • Comms • Demos • Pocket Book software • Games
 - JPEGs adult files removed!! • Midi files • Databases • Sillies
 - Strackers, Symphony & Coco files • Pin Board Apps • DTP
 - Red Dwarf demos • Utilities • Font Tools • !Earthmap • !TeX
 - **All files RISC PC compatible £36 fully inclusive.**
- Upgrade from PDCD-1 Issue 1 only £10 plus your old disk.**



PDCD-2 is 99% RISC PC compatible

Over 400 megs of software. Much of this is archived to make disc access much faster and gives you a lot more for your money. Complete with a printed catalogue

Clip Art - Books - Educational Software - Demos - Samples Music - Utilities - Morphs - Graphics - Games - Fractals - Animation - plus much more.....

All this for only £33 fully inclusive.

THE *Datafile*

Catalogue disc No CD ROM drive?

We can supply all our PD & shareware on DD and HD floppy discs. NEW 270meg Syquest service available. Our Catalogue and Ordering systems are the best available and the only one to be awarded the Archimedes World PowerPD award.

Send £1.50 in stamps and we will post via first class mail our Double DD cat disc or single HD version. Please remember to state DD or HD and enclose your name and address.

The Red Dwarf Collection

We have taken over Gem PD and now supply this exclusive collection. Supplied on 9 discs for only £10.58 fully inclusive. £1 of this goes to charity.

Gothic & Medieval
Fonts and Decoration

Collection of outline and Draw fonts along with Complimentary Decoration & Examples Supplied on 4 Disks. The Package includes 3 Outline Fonts

Karen
Charlie
Priory
VERSALS
Carol

There are 4 complete draw alphabets including dozens of decorative elements to customize your own letters plus dozens more draw objects for making up borders and motifs. The ideal package for creating Posters, Certificates Stationery, embroidery designs and much much more.

£37 inclusive.
of VAT & p&p

The Gothic & Medieval
Fonts Collection Pack Two

Abbey **Abbey Highlight**
El Cio Swashed
El Cio **El Cio Tooled**
Kells **Scriptora** **St. Madeus**
Bede **Bold** **Bold Tooled**

£40
Fully Inclusive



Tel 01934 823005

71 Anson Road, Locking
Weston-Super-Mare, Avon

fax 01934 823005



BS24 7DQ

Cover disc



Wavelength demo

Gamesware

WAVELENGTH is the latest game from the Gamesware stable, and is written by the same author who brought you *Hamsters*. Unlike many games these days, *Wavelength* is only available on the Archimedes, leaving PC and Amiga owners envious of the fast-scrolling graphics and furious gameplay of this excellent game.

Visitors to the *Acorn User* and Acorn World shows last year may have seen a taste of the game on the *Acorn User* stand, where the author was showing off a development version. Now that it has been released, you have a chance to try the game out for yourself, with the demo version of *Wavelength* on our cover disc.

The demo version contains one level, with the 'straightforward' task of destroying all the enemy – in other words, shooting everything in sight. Your ship is controlled from the keyboard using the Z and X keys to rotate anticlockwise and clockwise respectively. To fire, use Return. Shift thrusts the ship forwards and Space releases a smart bomb – vital for those tight corners when your shields are down and you're being shot at from all sides.

Fire power

You start the game with a 'beam' weapon which unleashes bolts of lightning that seek out and latch onto the nearest enemy. Some enemy emplacements release coloured squares when destroyed; these act as power-ups for different weapons. Light pink gets you bolts, dark pink a laser, blue a helix and yellow the beam.

As you collect more power-ups of the same colour your weapon gets stronger – you'll get a message each time you collect one telling you this – but be careful. If you suddenly collect a power-up of the wrong colour you may be back at a lower power with a different weapon.

Other power-ups released by destroyed enemy emplacements include a drone ship which flies along with you releasing bullets or homing missiles. Again, collecting several of the same type of drone improves the drone's power.

Getting blown up

Your ship has shields. These can be drained by being shot by enemy bullets, flying into a wall or hitting the enemy, and replenished from floating shield power-ups. Once your shields have gone you've had it and your ship explodes, releasing the power-ups you were carrying. If you are quick you can recover these at the start of your next life, otherwise the ship you're left with is rather basic.

The shield indicator is shown in the top left of the screen, with shield power

remaining shown in green. When your shield power is getting dangerously low, a warning appears on screen to let you know about it.

The firepower of the enemy ranges from the nasty but slow red globules released by the floating purple crosses to the fast and deadly starbolts fired by the gun emplacements. Once they've seen you, enemies will fire at you from off the screen which soon fills up with hostile firepower, hampering your mobility.

Wavelength is not really an 'intellectual' game, and the only 'strategy' involved is the strategy of blowing up everything in sight. It's fast, furious, and fun – a classic shoot-'em-up.

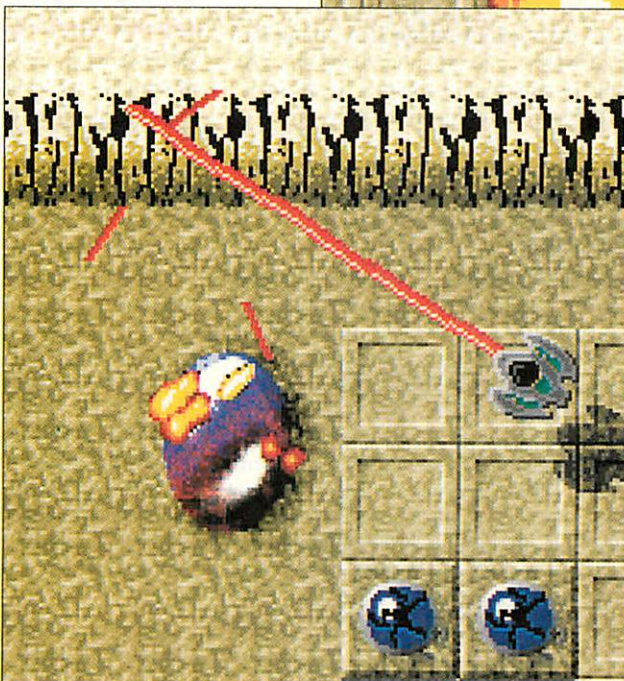
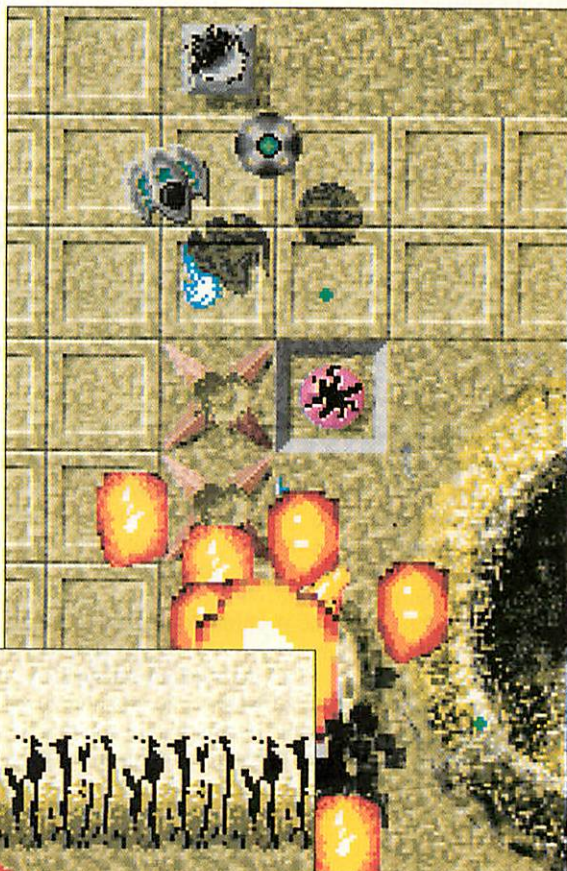

Product details

The version of *Wavelength* on the cover disc is a demonstration version, with only one level, and with the music cut down to fit on the disc.

The full version of *Wavelength*, with many more exciting levels to play and full music, is available for £19.95 + VAT from:

Gamesware

Tel/fax: (01703) 456523

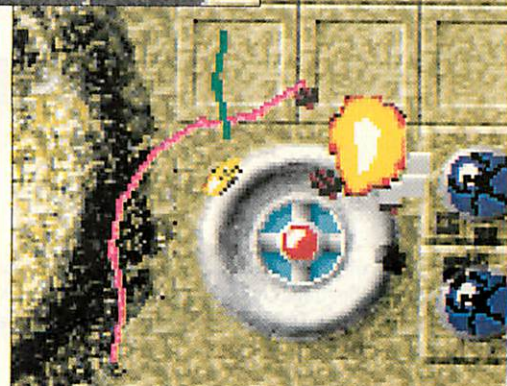

Wanted: software

AT *Acorn User* we are very keen to publish readers's programs on the cover disc. However, you may not be keen to lose all rights to your program. Perhaps you want to develop it further, release it into the public domain or sell an enhanced version at a later date. Well, with the *Acorn User* three month scheme, you can.

Three months then it's yours

With the unique *Acorn User* three month scheme, you retain copyright for your program at all times. What we pay for is the right to publish the program, which means that you must not release it in any form - commercially, on another magazine's cover disc or to a PD library - for three months after the publication of the magazine. After that, you are free to do what you want with the program.

In this way, you will not lose control over your software. You may, after all, have been developing the software for a considerable length of time. Plus of course you will be paid for your trouble, so you can't lose.

Public domain software

We at *Acorn User* are often asked why we don't put more 'public domain' - Freeware and Shareware - software on our cover disc. We are also approached by the occasional software author, keen to see his or her package getting a wider audience, but unhappy about the idea of losing rights to the program. We are keen that people wanting PD software should support one of the many excellent PD libraries in the Archimedes market - see the PD page in the magazine for details.

Having said this, we are on the lookout for good PD programs and demos of commercial software to use for the cover disc. As we do not pay for these, rights remain with the author at all times, and they may be posted to PD libraries and ftp sites freely.

If you are the author of a PD utility that you'd like to be spread more widely, why not send it in to us for possible use on the cover disc?

Sending in your software

When you've finished your masterpiece, pop it on a disc and send it along with the coupon below to: *Acorn User* cover disc, IDG Media, Media House, Adlington Park, Macclesfield SK10 4NP. A copy of the coupon is fine if you don't want to destroy your mint condition copy of *Acorn User*. If you prefer, you can e-mail it to david@acornusr.demon.co.uk.

Remember that if your program is short, off-beat, or illustrates some nice point of programming technique it would be better sent to *INFO at the same address. Dave Lawrence and Dave Acton are always on the lookout for programs of this nature, and you are more likely to get it published quickly through *INFO than on the main section of the disc.

Program submission coupon

Name:.....

Address:.....

.....

.....Postcode:

Phone no:

e-mail address:.....

Name of software:.....

The software submitted is my own work, and I agree to indemnify IDG Media against any legal action arising concerning the software.

Signature.....Date

Article tie-ins

Various authors

THIS month there are two items on the cover disc which tie in directly with articles elsewhere in the magazine.

The C archive contains a program *Kate4*. This is the familiar photo-database program from the past few issues, this time written with functions. There are two functions: readfilm() which reads the information into an array at one go, and printexposure() which prints out information for a single exposure. This demonstrates the passing of arguments, both as arrays and as elements of an array.

The *Star Info* archive contains *INFO programs to

go with the Dave 'n' Dave pages in the magazine. These are arranged in directories bearing the name of the author of the package, except for the *PocketBook* directory which has Dave Lawrence's *GPE* program for the *Pocket Book II*, and the *RiscPC* directory with some *INFO favourites tweaked to make use of the Risc PC's superior graphics.

Next month

Next month there will be a CD-ROM on the front cover of *Acorn User* containing a selection of the best *INFO offerings throughout the years, plus a lot more.

For those of you without CD-ROM drives, there'll be a 3.5in disc as well.

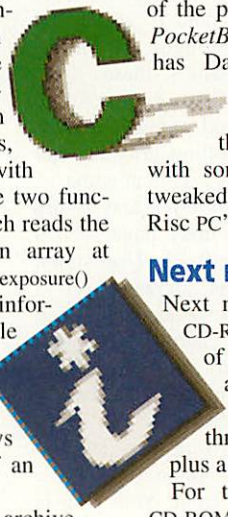

Disc problems?

OUR cover discs are tested thoroughly at every stage of production, but one or two faulty discs may slip through. If you suspect that you have a faulty disc, check whether it verifies by choosing 'Verify' from the menu produced from the floppy disc icon on the icon bar.

If the disc does *not* verify, then it is physically faulty and should be returned to TIB, TIB House, 11 Edward Street, Bradford, Yorkshire BD4 7BH, who will replace the disc free of charge. Note that this address has changed recently.

If it does verify, contact the editorial office at *Acorn User*,

IDG Media, Media House, Adlington Park, Macclesfield SK10 4NP or telephone (01625) 878888.

While we do test all the programs on the cover disc, we are unable to try them on all possible combinations of computer, hardware and software. We try to support RISC OS 2, but much of the software written for the disc does require RISC OS 3.1 or above, as software writers are switching to the new operating system. Do let us know of any problems.

The *Acorn User* cover disc has been checked for viruses using *Killer* version 1.900 from Pineapple Software.

Note for techies and other menu-haters

At the suggestion of a number of people on the usenet newsgroup comp.sys.acorn, who were unhappy with the way that magazine cover disc menus and de-archiving systems booted up automatically, there is now a system variable to prevent the *Acorn User* menu system from auto-booting. If you use the following, normally in your boot sequence:

```
Set Magazine$Disc -noboot
```

the menu system will not automatically boot when the disc is first accessed. You will then have to open the archives by Shift-double-clicking on the relevant pseudo-application and double-clicking on the archive file itself.

You can still run the menu program explicitly by double-clicking on it. Please let us know if you experience any problems with this, as it has not been possible to test it on all machine variations.



ZENTA

CD ROMS



Featuring over 500 different outline fonts, plus additional styles. This ROM is supplied with a comprehensive font selection application which displays full character previews for all fonts on demand.

Users of EasyFont will also find a handy linking option has been included to allow all fonts to be installed directly.

Also included on the disc are a variety of DTP files to allow users to easily obtain hardcopies of the fonts, which are shown in several formats.

FONT EMPORIUM £29.95 inc

No DTP user should be without the ClipArt Collection. It contains around 2,500 RISC OS draw format clips, plus Artworks files, and several thousand more mono sprite clipart files.

Almost all subjects are covered, images range from birds and animals, to computers and cartoons.

In total 500Mb of clipart is contained on the disc, all of which is accessed using a thumbnail clipart filing system. With rapid and keyword subject search facilities.

CLIPART COLLECTION £29.95 inc

Paradox
Dark Ages
Home Away
DINOSAUR



AVAILABLE SOON

Shareware '95 is the most comprehensive Public Domain, Freeware and Shareware Acorn CD ROM compiled to date.

It contains over 400Mb of RISC OS software, from Image Manipulation and International Map Creation, to Digital Video and Commercial Demonstrations.

SHAREWARE '95 £29.95 inc

The official Digital Symphony Collection, compiled in association with Oregon Software Developments.

Well over 1000 music tracks are included on the disc, enough to satisfy even the most avid devotee. Pieces are arranged by their music type, which include Classic, Piano, Rave, Pop and Mood. Also on the disc are several hundred samples for track creation.

SYMPHONY MASTERPIECES £29.95 inc

Zenta Multimedia
10 Ravenhurst Drive
Birmingham B43 7RS

Tel. 021 358 3054 Fax. 021 358 5969



easy to understand

easy to access

easy to use

difficult to ignore

That's what's unique about Longman Logotron. We are incredibly difficult to ignore. We have the solutions to meet all of your needs. We provide not only value for money, but clear information about *which* of our products will be of most benefit to you. Products which are easy to use and save time, all supplied with comprehensive but easy-to-read documentation.

Happily, this approach means that teachers choose us, time and time again. It's simply that we understand what users really want.

So call our user-friendly Helpline on 01223 425558, and ask for our brand new catalogue, to find out what we can do for you in 1995.



124 CAMBRIDGE SCIENCE PARK,
MILTON ROAD, CAMBRIDGE CB4 4ZS



Over 13 years experience in computer direct sales!

Vantage One

DIRECT

0113 237 4000

Fax **HOTLINE 0113 237 4163**

Vantage One Direct
 FREEPOST LS5106,
 Dept AU35, LEEDS LS7 3YY

- FAST, friendly, Acorn mail order service
- All our prices include VAT
- Delivery is **FAST and FREE!**
- Send us your order **FREEPOST**
- Discreet packaging for surprises!
- FREE quarterly news brochure** - just send us the coupon opposite (Freepost of course!) to reserve your copy. Details of all the latest releases, product descriptions and exclusive special offers to you, **DIRECT!**

Do you wish you knew what all these columns of titles are all about?!

Please phone or write (Freepost!) for our latest full, and free, catalogue. It's packed with product descriptions, review comments and special offers! The Spring issue is available now - don't miss it!

0113 237 4000

Software Clearance SALE

Only whilst stocks last - please call to confirm availability!

0113 237 4000

A3000 Disc Buffer	£23.50	Imagine v1	£19.95
A5000 Disc Buffer	£33.95	Imagine v2	£25.95
A5000 2MB (to make 4MB)	£89.95	Logix	£76.95
Archivist Pro	£31.95	Magnetoids	£16.95
ARC-PCB Professional	£184.95	Office Tools	£269.95
ARC-PCB Schematics	£226.95	Ollie Octopus Sketchpad	£9.95
Art Machine Pack 1	£19.50	Pandora's Box (2MB)	£9.95
Art Machine Pack 2	£19.50	Payroll Manager	£57.95
Balloons/Zoo	£15.95	Photouch	£51.95
Christmas Adventure	£13.95	Power ROUTER	£45.50
Datagraph	£24.95	Punctuate	£12.95
Demon's Lair (2MB)	£29.95	QD Bug	£44.95
Digital Symphony	£39.95	Quark	£14.95
Excellon-DRILL	£49.95	Realtime Solids Modeller	£129.95
Exotic Adventures S. Layne	£9.95	Risc Forth	£65.95
First Impression (Bk & Disc)	£19.95	Small	£13.95
Gerber Plot	£49.95	Spy Snatcher	£9.95
Hiemdal	£9.95	Super Dump	£16.50
Holed Out Crpdm	£9.95	Time Machine (2MB)	£14.95
Imagery	£39.95	Tiny Puzzle	£15.95
		Word Bank	£12.95

Only whilst stocks last! All prices include VAT & UK mainland carriage

INKJET Printers

Prices include cable, carriage & VAT!

	MONO		COLOUR
HP Deskjet 320	£230.24	HP Deskjet 500C	£304.33
Epson Stylus 800+	£239.11	HP Deskjet 560C	£430.64
Canon BJ200	£255.56	Epson Stylus Colour	£429.46
HP Deskjet 520	£260.26	Canon BJC600	£430.64

All prices INCLUDE cable, UK mainland carriage and VAT!

Powerpads!



6 Button Joypad for all 32-bit Acorn computers!

Single Player **£27.95!**
 Dual Player **£32.95!**

- Programmable Auto Fire
- 100% Acorn joystick compatible
- Supports most Archimedes games
- Simply plugs into printer port
- Powerful software included for creating your own games modules!

Free Splat Mat!
 Worth £4.95

Our spring catalogue is now available. Please call or write for your **FREE copy!**



Rosie & Jim
 Duck loses his quack
 £11.75

BUY BOTH & claim a free SPLAT MAT!



Rosie & Jim
 Jim gets the Sneezes
 £11.75

FREE Splat Mouse Mat when you buy any of these too!

- All New Talking Alphabet Arcventure 1, 2, or 3
- Around World in 80 days
- Atreus
- Badger Trails
- Bodywise
- Highlighter
- Look! Hear! Volume I
- ORT Stage 2 Talking Stories
- ORT 2 MORE Talk Stories A
- ORT Stage 3 Talking Stories
- Sherston Naughty Stories 1
- Sherston Naughty Stories 2
- The Crystal Maze
- The Crystal Rain Forest
- Viewpoints
- Voyage of Discovery

Educational Software

	SRP	Our Price
10/10 Dinosaurs	25.95	21.50
10/10 Driving Test	25.95	21.50
10/10 Early Essentials	25.95	21.50
10/10 English	25.95	21.50
10/10 Essential Maths	25.95	21.50
10/10 Essential Science	25.95	21.50
10/10 Structured Spelling	25.95	21.50
10/10 Spell/Punct'n (Soon)	25.95	21.50
10/10 French	25.95	21.50
10/10 Junior Essentials	25.95	21.50
10/10 Maths-Algebra	25.95	21.50
10/10 Maths-Geometry	25.95	21.50
10/10 Maths-Number	25.95	21.50
10/10 Maths-Statistics	25.95	21.50
Adventure Playground	25.99	22.35
A Mouse in Holland	34.66	31.75
All New TALKING ALPHABET		35.19
Amazing Maths	23.44	19.95
Amazing Ollie (4+)	17.99	15.95
An eye for Spelling	44.06	37.50
Ancient Greece	29.38	25.95
Ancient Egypt	29.38	25.95
Animated Alphabet		29.32
Animated Numbers		29.32
Arcventure 1 - The Romans		41.07
Arcventure 2 - The Egyptians		41.07
Arcventure 3 - The Vikings		41.07
Around World in 80 Days		52.82
Astro	35.25	31.95
Aztec		52.82
Badger Trails		52.82
Balloons & The Zoo	23.50	15.95
Bert Boot	7.95	6.95
Best Four Adventure	46.41	41.95
Best Four Language	46.41	41.95
Best Four Maths	46.41	41.95
Betsi	40.54	37.50
Billy - Bothersome Bully		12.87
Bobby the Boastful Bird		12.87
Bodywise		52.82
Bookstore (Primary)	46.41	40.95
Bumper Disc 1 or 2 (Each)	23.95	19.95
Calabash Pirates (7-11yrs)	25.99	21.95
Cars in Motion	58.69	51.95
Castle Life	52.88	48.95
Castle of Dreams	25.99	23.50
CD - Francais (CD-ROM)	111.63	104.95
Chemistry Superstar	27.03	24.50
Children's Micropedia CD	105.75	99.95
Cistercian Abbeys	52.88	48.95
Clarence the Clumsy Cat		12.87
Coffee (9-15yrs)	34.99	30.50
Complete Control	46.94	41.95
Concept Designer Pack	29.38	25.50
Connections		37.54
Control Logo	29.38	24.50

	SRP	Our Price
Crossword + (8-Adult)	19.95	16.95
Darryll the Dragon	22.91	20.50
Derek's Dopey Dinosaur		12.87
Dinosaur Discovery	32.31	28.95
Dktp Folio Editors Pk	26.44	23.95
Dktp Folio W. War 2 Pk	26.44	23.95
Dktp Folio Christmas Pk	26.43	23.95
Dktp Folio - Festive Folio	22.91	19.95
Dktp Folio Space Pk	26.43	23.95
Dktp Folio Maths Pk	26.43	23.95
Doris the Doty Dog		12.87
Earthwarp	29.96	25.50
Edwina's Energetic Elephant		12.87
Egypt Extras - Genesis	17.63	15.95
Equazor	57.57	42.35
Farmer Giles 2	20.39	14.95
First Logo	28.20	24.50
First Words with Smudge	25.99	21.95
Flight Path	34.99	30.55
Flossy the Frog	28.79	26.95
Forensic	27.03	25.95
Formulix	81.07	76.95
Freddy Teddy (3-7yrs)	17.63	15.95
Freddy Teddy's Adventure	17.63	15.95
Fred Teddy - Izzy & Lizzy	29.38	26.50
Freddy Teddy - Playground	29.38	26.50
Frontier 2000	93.94	89.95
Frontier 2000 (CD)	129.25	116.50
Fun & Games (5-9yrs)	19.95	16.95
Fun School 3 Series (Each)	24.99	19.95
Fun School 4 Series (Each)	24.99	19.95
Geordie Racer	29.96	25.50
Giant Killer Project Pack	32.25	29.95
Goldilocks (CD)	47.00	43.95
Gordon's Groovy Granny		12.87
Granny's Garden	28.79	26.95
Granny's Garden (CD)	39.95	32.95
Guardians Greenwood (CD)	58.16	54.95
Graph-It		23.44
Greeks	52.88	48.95
Hillghter		41.07
House of Numbers (6-13yrs)	27.03	22.95
Imagine V2 (2MB) Special!	47.00	25.95
Insight	81.08	71.95
Investigating Maths (9-13yrs)	44.06	39.95
Junior Pinpoint	34.08	29.50
Kid Pix	44.06	39.95
Landmarks Packs (Each)	29.96	25.50
L/Mks PinPoint Datafiles (Each)	16.45	14.95
L/Mks Microworlds Pks (Each)	29.96	25.95
Letters & Pictures (6-8yrs)	23.50	19.95
Lexicon German	39.00	22.50
Lexicon - Russian	50.00	28.95
Life in Tudor Times	29.38	25.95
Linkword French	39.95	34.95
Linkword German	46.95	26.95

	SRP	Our Price
Linkword Spanish	46.95	26.95
Look & Hear Packs (Each)		14.04
Look & Hear Volume 1		70.21
Lots more Fun & Games	22.95	19.95
Lucy the Little Liar		12.87
Magpie	69.33	58.75
Make "n" Match	9.95	8.95
Mapping Skills	35.19	31.95
Maps & Landscapes 1 or 2 (ea)	27.03	22.35
Maths Circus	32.31	29.50
Maths Pack 1 (5-7yrs)	12.95	10.95
Mega Maths (A-Level)	25.22	21.95
Micro English (8yrs - GCSE)	25.22	21.95
Micro French (8yrs - GCSE)	25.22	21.95
Micro German (8yrs - GCSE)	25.22	21.95
Micro Maths (11yrs - GCSE)	25.22	21.95
Micro Science (Byrs - GCSE)	25.22	21.95
Micro Spanish (Byrs - GCSE)	25.22	21.95
Music Box	41.13	39.95
Navigator	52.88	48.95
Newton	23.50	19.95
Noddy's Playtime (OS 3 & 2MB)	25.99	21.15
Numbers in the Nat. Cur.	44.06	39.95
Numbers/Pictures (4-6yrs)	23.50	19.95
Number Tiles	35.25	32.95
Numerator	45.83	38.75
Ollie Octopus Sketchpad	17.99	9.95
ORT Stage 2 - Talking Stories		47.00
ORT Stage 2 MORE Talk Stories A		47.00
ORT Stage 3 - Talking Stories		47.00
PinPoint Datafiles (Each)	16.45	14.95
Pirate	27.03	21.95
Playdays	25.99	23.50
Podd	35.19	31.95
Polyminoes	29.38	26.50
Primary Maths (3-12yrs)	25.22	21.95
Primary Nature	52.88	49.95
PrimeSolver	92.83	84.50
Puncman 1&2 (7-13+)	23.50	19.95
Puncman 3&4 (8-14+)	23.50	19.95
Puncman 5, 6, & 7 (8-15+)	23.50	19.95
Punctuate Special!	23.50	12.95
Reversals	23.50	19.95
RoboLogo	49.95	44.95
Rosie & Jim - Duck		11.75
Rosie & Jim - Sneezes		11.75
Round World Yacht Race	34.99	29.95
Saxon Life	52.88	48.95
Screen Turtle (Desktop)	52.88	48.95
Search & Rescue (9-15yrs)	34.99	29.95
Sellardore Tales		29.32
Sherston Naughty Stories Pk 1		64.33
Sherston Naughty Stories Pk 2		64.33
All 12 Naughty Stories on CD ROM	102.81	
Skyhunter	29.96	25.50
Smudge the Spaniel	25.99	21.95

	SRP	Our Price
Somerset Talking Cmp Project	34.08	28.95
Space City		34.02
Space Ship Mada		34.02
Spelling Week By Wk (6-13)	27.03	22.95
Splash		24.62
Spy Snatcher Special!	15.00	9.95
Stg of the Dump		29.32
Talking Clocks	41.13	37.95
Talking Rhymes Pack	47.00	42.95
Tasmin's Terrible Trantum		12.87
Terry's Tricky Trainers		12.87
The Art Mchne Pk 1 or 2 (Ea 9+)	35.25	19.50
The Crystal Rain Forest		52.82
The Puddle & The Wardrobe	23.50	21.50
The Worst Witch		34.02
Through the Dragon's Eye	29.96	24.95
Time Detectives - Victorians		52.82
Time Traveller - Britain 1930's	41.13	34.95
And Resource Pack	70.44	64.95
T. Trav. Exp. Trade & Ind.	41.13	37.95
And Resource Pack	70.44	64.95
T. Trav. Make your Own	44.06	39.95
T. Trav. Making of the UK	41.13	37.95
And Resource Pack	70.44	64.95
T. Trav. Medieval Realms	41.13	37.95
And Resource Pack	70.44	64.95
T. Trav. Tudors & Stuarts	41.13	37.95
And Resource Pack	70.44	64.95
Time Traveller - Victorians	41.13	37.95
And Resource Pack	70.44	64.95
Tina's Terrible Trumpet		12.87
TinyLogo/Tiny Draw (4-9yrs)	29.38	26.50
Tiny Puzzle	23.50	15.95
Toby - Troublesome Tractor		12.87
Topographer	79.95	68.95
TV Fun & Games	22.95	18.95
Viewpoints		52.82
Viking Invaders	52.88	48.95
Voyage of Discovery		41.07
Weatherman	9.95	8.95
White Facts	23.50	19.95
Winlogo	81.08	72.95
Word Bank	23.50	12.95
World Map Study	69.91	64.95
Yes Chancellor 2	27.03	24.95

Prices include VAT & are correct E&OE

Extra discount for educational establishments - send for a Teacher Pack or phone for details! Site Licences also available!

WHAT YOU SEE IS WHAT YOU PAY! Everything Inc VAT & carriage!

WHAT YOU SEE IS WHAT YOU PAY! Everything Inc VAT & carriage!



GAMES

	SRP	Our Price
Acceptable Rate of Loss	24.99	22.50
Air Supremacy	24.95	21.95
Aggressor	14.99	12.95
Aldebaran	34.90	30.50
Arcturus (OS3 & 2MB)	24.95	22.50
Aries	29.95	26.95
Battle Chess (2MB)	29.95	23.50
Birds of War (2MB)	34.95	28.25
Black Angel	34.95	28.25
Blood Sport	14.99	13.50
Break 97/Superpool	24.95	22.50
Burn 'Out (OS3 & 2MB) March	24.95	22.50
Cannon Fodder (2MB)	25.99	22.35
Carnage Inc (2MB)	25.99	21.15
Champions	29.95	24.75
Manchester Utd. (Player: Khan Squash, Bowling)		
Manchester Utd. World Class Leaderboard		
Chaos Engine (Soon!)	25.99	23.50
Chess 3D	24.95	22.85
Chocks Away Compendium	34.95	29.50
Choppers Force	29.95	22.50
Chuck Rock	24.95	9.95
Cyber Chess	34.95	28.25
Cyber Ape Soon!	19.99	17.95
Cygnus Triple Pack		19.95
Tower of Babel, IronLord & Twinworld		
Douglas of Saragosa (March)	34.95	31.95
Diggers	29.95	25.95
Dreadnoughts	34.95	31.95
Dreadnoughts - Bismarck	16.95	14.50
Dreadnoughts - Ironclads	16.95	14.50
Dune 2 (OS3.1) Out Now!	34.99	31.95
Dungeon	34.95	28.25
EGO Repton 4	24.95	21.95
Elite	39.95	34.95
Enter the Realm (2MB)	25.95	21.15
E-Type Compendium	24.95	22.50
E-Type 2 (2MB)	24.95	22.50
Fire and Ice (Soon!)	25.99	23.50
Flashback	27.99	24.95
Flight Simulator Toolkit	44.99	29.95
Formula Two Thousand	24.99	22.50
Global Effect (Hopefully Soon)	29.95	26.95
G O D S - budget price!	24.95	9.95
Haunted House (2MB)	25.99	21.15
Hero Quest	29.99	23.50
Interceptor 2	36.00	29.95
James Pond - Budget price!		9.95
Khan Squash		9.95
Lemmings	25.99	19.95
Lemmings 2/Tribes (2MB)	29.99	23.50
Lemmings/Oh No Pk (Rspc)	29.99	26.95
Lotus Turbo II	25.99	21.15
Mad Professor Mariarti		9.95
Mad Professor Mariarti	25.99	21.15
Manchester Utd		9.95
Manchester Utd Europe		9.95
Oh No! More Lemmings	19.99	17.65
Play It Again Sam	24.95	21.95
Compendium: Action, No Escape and Hostages		
Play It Again Sam 2	24.95	21.95
Arcturus, Repton 2 and Masterbreak and ZARCH		
Play It Again Sam 3	24.95	21.95
Top Beasts, Zeleates, Leroove & Superior Golf		
Populous	29.99	23.50
Quark	24.95	21.95
Quest for Gold	25.99	22.35
Real McCoy 2	34.95	25.85
Arcturus, Hired Out, The Olympics, Inertia		
Real McCoy 3	34.95	25.85
Neonra, Forward, Dropship, The Wing Game		
Real McCoy 4	34.95	25.85
Galeatic Dan, Grievous Bodily ARM, Cataclysm, and X-Fire		
Repton 3	24.95	21.95
Revelation (Krisalis)	25.99	9.95
Robocod (James Pond 2)	25.99	22.35
Rome AD (Hopefully Feb '95)	29.95	26.95
Sally and Wally (2MB)	24.95	22.50
Saloon Cars Deluxe	34.95	28.25
Saloon Cars Extra Crses	34.95	28.25
Scrabble	27.99	23.50
Sensible Soccer	25.99	22.35
Sim City	34.99	25.85
Sim City 2000 (Rspc)	39.99	36.95
Sim City 2000 (A5000, 4MB, & Multisync or VGA Monitor only)		36.95
Simon the Sorcerer (OS 3.1)	39.99	36.95
Soccer Kid - (Hopefully Soon!)		TBC
Speedball II	25.99	21.15
Spheres of Chaos	24.95	21.95
Spookiboid Special Price!	24.95	14.95
Starfighter 3000 (2MB)	29.99	27.95
Striker (Soon!)	25.99	23.50
Stunt Racer 2000	34.95	28.25
Stunt R/2000 Extra Tracks	19.95	17.95
S.W.I.V.		9.95
Technodream	24.95	21.95
The Crystal Maze (Plus Free SPLAT MAT)	24.99	39.95
The Cobalt Seed (Soon!)	24.99	22.50
The Krisalis Collection	29.99	21.25
Mad Professor: Mutant, Terrance, Pipemania, and Revelation		
The Last Ninja	24.95	21.95
Ties v2.7	19.75	16.95
Virtual Golf (2Mb)	34.95	26.95
Virtual Golf - Augusta Pack	16.95	14.95
Warp Riders (Soon!)	19.99	17.95
Waterloo	25.99	21.95
Wavelength	19.99	17.95
Wolfenstein 3D	20.00	26.95
Xenon 2	25.99	22.35
Zarch	19.95	15.95

UTILITIES

	SRP	Our Price
ARCAlcuate	25.95	21.15
NightSky	79.95	73.95
Speech 2	29.95	26.95
Speech 2 + French (Soon!)	34.95	31.95
Speech 2 + German	34.95	31.95

WORD PROCESSORS

	SRP	Our Price
Desktop Thesaurus	22.33	19.95
EstiWord	29.95	27.95
EasyWriter v3.01	176.25	134.95
Impression Style	91.08	99.95
Pendown 2	63.45	52.95
Pendown Eticles	63.45	52.95
Primeword Plus	92.83	78.75
Primeword	49.75	44.95
Starts Write	91.08	64.65
Talking Pendown	75.20	61.95
Techwriter	233.83	174.95
Touch Type (Typing tutorial)	51.04	44.65
Words	69.33	63.50
Wordworks	45.83	41.95

SPREADSHEETS

	SRP	Our Price
Advantage	57.58	53.95
Europa	116.33	99.95
ProSHEET v1.4	26.94	43.95
Resultz	92.83	84.95
Schema 2	135.00	111.65

DATABASES

	SRP	Our Price
Alpha Base	51.95	47.95
Datapower	175.08	144.50
DataVision	99.95	84.95
Desktop Database	57.58	52.95
Flexfile	39.95	34.95
Junior Pinpoint	34.08	29.50
Knowledge Organiser 2	79.95	73.95
Masterfile 3	57.58	50.55
Multistore II	79.95	71.95
N-Store v2	29.99	27.95
Pinpoint v2	116.33	92.95
Recall		41.07
Recordz	116.33	112.95
S-Base 2 Developer	116.33	99.95
S-Base 2 Developer *	123.50	134.95
S-Base 2 Personal	57.58	53.95
The Junior Database	57.58	52.85

INTEGRATED OFFICE

	SRP	Our Price
Almanac 3	85.00	75.25
Desktop Office V2	49.05	46.95
DataVision	99.95	84.65
Firework	116.33	99.95
Firework Pro	125.08	164.95
Pipedream 3	69.33	64.95
Pipedream 4	116.33	99.95

ACCOUNTS

	SRP	Our Price
Accounts Manager	351.33	299.95
Home/Club Accounts	34.95	31.95
Payroll Manager	93.94	84.50
Personal Accounts V3.12	49.95	44.50
Prophet V1.43	199.75	170.45

BUSINESS

	SRP	Our Price
iShares	39.95	36.95
Chartwell	29.95	26.95
DeskEdit V4	31.95	29.45
GraphBox Professional	99.95	89.95
Impression Business Suppl.	57.58	43.50
Shareholder V2	125.00	112.50
Shareholder Pro v3.17	146.95	139.95
Showpage	175.07	163.35
Sleuth V2 (Soon)	116.33	104.95

PRINTER DRIVERS

	SRP	Our Price
BiLOEX Turbo Driver	57.58	49.35
BiC600/800 Turbo Driver	57.58	49.35
BiC4000 Turbo Driver	57.58	49.35
Epson Stylus Turbo Driver	57.57	49.35
H.P. Turbo Driver	57.58	49.35
Print Shop	25.95	23.50
Spooler	15.00	13.95
Star/Epson Colour Driver	17.63	14.95
Super-Plot	24.95	21.95
NB All Turbo drivers require OS 3.1		

COMPUTER AIDED DESIGN

	SRP	Our Price
Apollonius PDT	176.25	164.50
ARC-PCB V1.9	174.42	109.95
CADet	99.95	89.95
Kiddicad	52.88	48.95
Oak PCB II	82.25	77.50
PreCAD	581.63	528.75
SolidCAD	83.94	87.95
SolidTOOLS v5.1	275.00	247.95
Worracad	82.25	76.35

LANGUAGES

	SRP	Our Price
Arch. Assembly Language	22.11	17.50
Cambridge Pascal	82.25	73.95
Desktop C (2MB min)	269.08	144.95
HiP	116.33	104.95
Risc Forth	99.95	89.95
RoboLOGO	49.95	44.95
Winlogo	81.08	72.95

COMMUNICATIONS

	SRP	Our Price
ArcComm V2	69.33	55.25
Arcterm 7	79.95	68.15
Hearsy 2	88.13	69.95

DTP & IMAGE PROCESSING

	SRP	Our Price
Arclight	52.88	42.95
ARCtst	25.95	21.15
Art School	29.95	26.95
Artisan 2	61.95	49.35
Artworks	198.57	154.95
Artworks (CD)	198.57	154.95
Atelier	34.95	31.95
Card Shop	24.95	21.95
Chameleon	44.06	41.95
Composition (Risc PC)	169.95	159.95
Desktop Folio	56.99	53.95
Euclid	58.75	52.95
Eguzor	57.57	42.35
Film Maker v5.1	58.69	54.95
First Page	57.58	49.95
Folio for the Archimedes	29.38	26.95
Font FX		11.75
Formulix	81.07	76.95
Hiliter		41.07
Image Outliner	57.58	53.95
Illustrator	46.41	46.95
Impression Business Suppl.	57.58	43.50
Impression Publisher	198.57	154.95
Impression Publisher Plus	351.32	274.95
U/G from Pub to Pub Plus	152.75	124.95
Impression Style	116.33	99.95
Kid Pix	46.41	39.95
Mogul	29.38	28.25
Morpheus	44.95	39.95
Ovation	81.08	72.95
Photopia	24.95	21.95
Photo Touch	79.95	71.95
Poster	99.95	94.95
PrimeArt	49.95	44.95
PrimeMover	69.95	62.95
Pro Artisan 2	135.00	119.95
Pro Artisan 2 (CD)	159.99	151.95
Pro Artisan 24 (Risc PC)	169.95	151.95
QPaint	49.95	44.95
Render Bender 2	49.95	46.95
Rephorm	58.75	52.95
Revelation 2 (CD)	57.58	53.95
Revelation Image PRO 24-bit	57.58	53.95
Shape FX		11.75
SolidRENDER v5.1	99.95	89.95
Splash		24.62
Splice	35.25	31.95
The Complete Animator	99.95	89.95
Titler	99.95	89.95
Tween	35.25	31.95
Type Studio	34.08	29.95

CD-ROMS

	SRP	Our Price
Applications	198.57	154.95
Artworks (CD)	111.63	99.95
CD Francis	159.99	151.95
Revelation 2 (CD)	57.58	53.95
Information/Clip Art		
Artworks Clip-Art	22.33	19.95
Bitfiles	57.58	53.95
Children's Microcopia	105.72	99.95
Photobase Decades - 1960s	57.58	53.95
Photobase Decades - 1950s	57.58	53.95
Photobase Decades - 1940s	57.58	53.95
Photobase Decades - 1930s	57.58	53.95
Photobase Decades - 1920s	57.58	53.95
Photobase Decades - 1910s	57.58	53.95
Photobase Decades - 1900s	57.58	53.95
Photobase Landscapes	57.58	53.95
Photobase Science	57.58	53.95
Sherston Naughty Stories 1&2		102.81

DTP - CLIP ART

	SRP	Our Price
Cartoons Library Pack	19.95	16.95
Children's Graphics Pack	19.95	16.95
Christmas Allsorts	19.95	19.92
Christmas Greetings Pack	19.95	16.95
ClickArt	76.38	69.95
Clip Art Set 2	35.19	31.95
Clip Art Pack (VTI)	23.49	19.95
Decorated Alphabet Pack	19.95	16.95
Designers Graphics Pack	19.95	16.95
DT Library Pack 1	29.95	25.45
Ethnic Borders (for Poster)		21.75
Food for Thought		21.09
Glimpse		11.99
History Costume Library	19.95	16.95
Illustrators Graphic Pack	19.95	16.95
Jurassic Graphics Pack	29.95	26.95
Military History Pack	19.95	16.95
Nature Library	19.95	16.95
Prehistoric Animals Pack	19.95	16.95
Science Graphics Pack	29.95	25.45

HARDWARE

	SRP	Our Price
Seashore Guide Pack	19.95	16.95
Split an Image		21.09
Sports Graphics Pack	29.95	25.45
Tools Graphics Library	29.95	25.45
Transport Graphics Pack	29.95	25.45
World Geog Maps Pack	29.95	25.45
World Wildlife Pack	19.95	16.95

BOOKS/TUTORIALS

	SRP	Our Price
'Draw Help		15.95

Thoroughly modern masters

Kathy Brown takes a trip into the world of professional artists and their Acorns, and discovers that the results are stunning and contemporary.

Opinions about what constitutes 'Art' are being ever more frequently voiced. In the press, on TV, in the home, and at the hairdressers, critics, both professional and amateur, cite their indignation at just what is, or is not, acceptable. The verdict on computer-generated art has still not been reached, and given the rate of evolution of digital graphics tools and media, it seems likely that the jury will be out for some time.

Fortunately, though, there is no real

authority to dictate a final solution; it is at the whim of the individual to decide whether a computer-painted image mocks reality or, rather, if the skill of the computer artist is, in itself, worthy of merit. And what about digitisers and scanners? Does their use pre-empt originality? Or does the end justify the means?

Confucius say these are lofty questions indeed, but given a 32-bit RISC machine, some decent software and a bit of time

and effort, much can be achieved. We in the Acorn fan club are lucky to have at hand some of the finest graphics tools around, and some highly skilled artists to exploit them. The gallery which follows on the next five pages is a round up of a representative sample of some of these modern masters, to provide an exhibition of all that is great and good in RISC OS art. You are hereby invited to take a wander through *Acorn User's* very own gallery, and to judge for yourselves.

Kane Clover

Kane is only 13-years-old and is a pupil at Altrincham Grammar School for Boys. His talent came to light after he submitted an image for *Acorn User's* Picture of the Month competition. His father is an airbrush and oil painter; pictures are hung all around the house, which Kane supposes must be of influence.

When Kane is at home his Risc PC is on from 9 in the morning till 9 at night, and he laments the fact that 'my school only has networks of boring 486s and 286s'. He mostly uses *ProArt24* and *ArtWorks*, but also *DA's Picture*, *Euclid* or his own programs in combination to achieve exciting effects. As to his future: 'It is impossible to say what I'll be doing in a few years time, which in my opinion is a good thing. It'd be boring if I could!'

'Sense' by Kane Clover

This illustration was created using *DA's Picture* and *ArtWorks*. The background was created by combining *DA's* graduation tool with the airbrush, adding a scaled-down copy in the centre of the canvas. Kane masked around this and sprayed white to pick out the border. The ghostly hand was grabbed by a digitiser, then added as a mask to the existing picture. The mask was then inverted to act as a stencil for a low opacity airbrush. The eye was created in *ArtWorks*, with white and black shapes used to get a wood cut effect. The result is a simple, yet compelling piece with a mood all of its own.

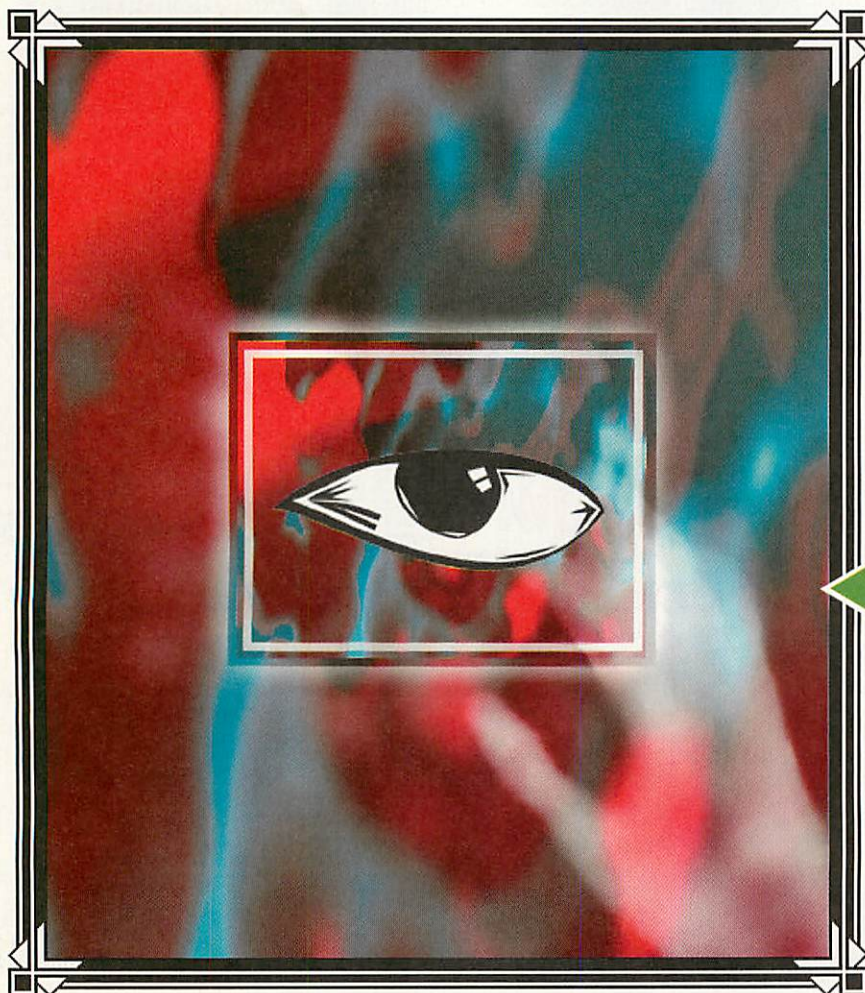

Murtaza Sheikh

At 15-years of age, Murtaza has already won praise on the *Acorn User Graphics* page for his mastery of *Draw*. He became interested in computer art a few years ago after testing out the *Paint* utility on the family's (then) brand new A3010. Later, he became bored of *Paint* and moved on to *Draw*, producing high quality pieces after two or three months of experimentation.

Says Murtaza: 'The only thing that stops me from creating even better clip art is the speed and the memory of our 2Mb A3010. If anyone out there wants to offer me work using *Draw*, please remember I have a family of four kids to feed, their mother has fallen ill, and her operation requires a lot of money.' Seems to me the man *deserves* a nice shiny Risc PC...

'Predator 3' by Murtaza Sheikh

An outstanding example of what can be achieved using *Paint*, Acorn's most basic bitmap painting program. This image differs from the others in having been created in a 256-colour mode on a 2Mb A3010. Murtaza was only 13 when he painted this image which contains an immense amount of detail in spite, as the artist puts it, of being 'simple to do, although very long and boring.' The highlighting of the different parts of the creature's body was done by grading each area from the darkest shade of a hue to the lightest, with the 'electric' effects added last, to obtain a picture which simply effuses menace.



Alan Burns

Well-known as the originator of Computer Concepts' 'Mini' clipart, Alan has recently been working on new material for CC's PC package, *Camelot*. His interest in the computer as an artistic medium arose through the need to have absolute precision in technical drawing.

Initially he wrote his own art programs to satisfy his own standard (he wrote *MicroBrush* for the BBC), but then *ArtWorks* came on the scene, and eclipsed *all* contemporary vector

graphics programs. His tip for *ArtWorks* users is to 'decide, before beginning a drawing, if you are really prepared to finish it. Spectacular work can be achieved, but you will usually have to put in an inordinate amount of time.'

If you're looking for someone else to put in the hard work on your behalf, Alan

is currently available for commissions on 0181-644 6643.

'Midget' by Alan Burns

This is one of three motor-vehicle clipart pieces by this artist supplied in the *ArtWorks* package. This version of Alan Burns' own MG Midget has been brought up to date with a few recent modifications. The image, which took almost two weeks to complete, was drawn from a photograph. Alan made use of *ArtWorks*' layering facility to keep screen redraw times down.

'You couldn't attempt a comparable image in *Corel Draw*; it wouldn't just be frustrating waiting for the screen to redraw, it would be impossible.' Tiny details such as the perfectly-reproduced tax disc and the reflected landscapes in the headlights make this image exemplary of the power of *ArtWorks* as a drafting and illustration tool.

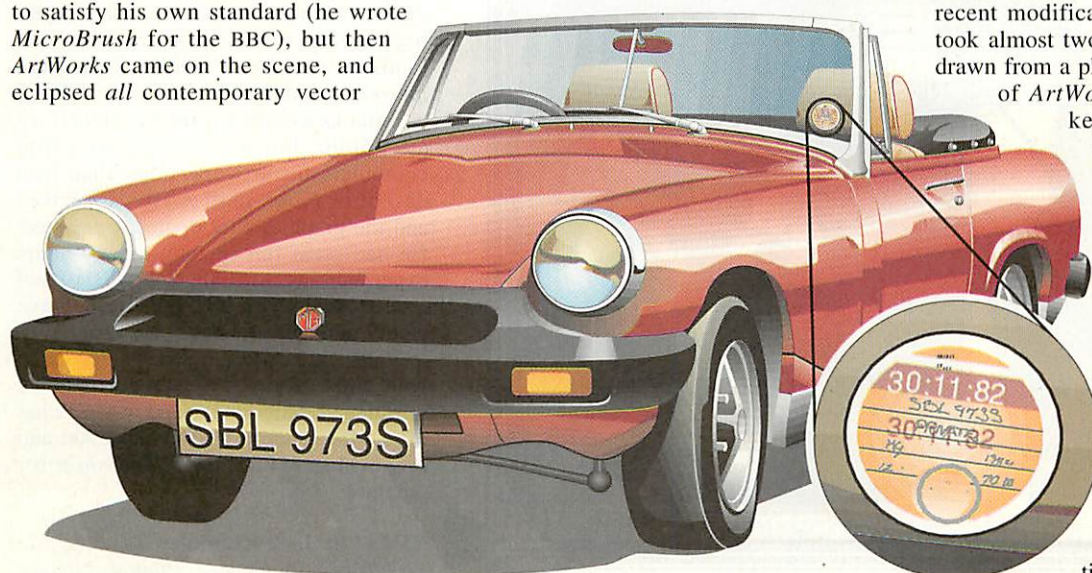

Walter Briggs

Although an established freelance illustrator and graphic designer for over 20 years, Walter sprang to fame as the very first winner of Computer Concepts' clip art competition in 1993. His company, Kingfisher Graphics, has since gone from strength to strength, with Walter's work being commissioned for games, software packaging and magazine covers (including *Acorn User*).

His story is all the more impressive when you consider that Walter, who suffered a back injury in 1990, does most of his work Michaelangelo-style, lying down. His preferred medium is Pineapple Software's *Studio 24*, although he is equally adept at using vector graphics and desktop publishing software. Walter is currently accepting commissions, and can be contacted at this address: Kingfisher Graphics, 24 Ashfield Court, Donaghadee, Co. Down BT21 0BF; Tel: (01247) 888698.

'Portrait of Girl in American Football Helmet' by Walter Briggs

Walter's preferred tool is the airbrush, both for computer work and conventional art. This image was a particular challenge because of the smooth surfaces; the helmet being smooth and shiny, the girl's face smooth and soft, with well-blended skin tones being especially difficult to achieve.

Walter used the airbrush and smoothing tool in *Studio 24*, gradually adding gentle tones to the face and highlights to the helmet. The use of the Smudge brush can be seen in the hair structure. The completed image is a fine example of airbrush work, and Walter's grassroots artistic talent shines through.



Jack Kreindler

Jack, *Acorn User's* Graphics Editor, began to use computers at A-Level where his school's IT department, equipped with Acorns, provided the means for word processing his A-Level art thesis on computer graphics. After mastering *Impression Junior*, Jack became familiar with *Draw*, *Paint*, *Revelation ImagePro*, *ProArtisan* and *Render Bender*.

This convinced him to invest in an A5000, but he didn't start using computers for artwork, other than icon design in *Paint*, until *ArtWorks* arrived and the graphics card upgrades emerged. He had great fun spending many hours experimenting with his Canon BJ10 and colour separation programs to achieve colour proofs from limited resources.

Now Jack uses a 26Mb Risc PC with 2Mb VRAM, a Wacom A5 pressure sensitive graphics tablet, and, when he has to, a Mac Quadra 660AV and 900 and PowerMac 8100 using *Photoshop* for scanning.

'UMA' by Jack Kreindler

The concept for *Polyp Friction* was to take

Dave Wilcox

In 1994 Dave was a runner-up in the Computer Concepts clip art competition. He has been illustrating as a hobby for many years, mostly by traditional methods; however his fascination with computer-generated art and animation began when he discovered ray-tracing several years ago at work, then got hooked.

'The great thing about ray-tracing,' says Dave, 'is the combination of photographic realism with artistic surrealism'. To create his 3D masterpieces, Dave uses a 25Mhz A5000 fitted with an FPA (Floating Point Accelerator). He has just finished work on a rotating logo for Topologika, to provide an eye-catching display at exhibitions, and is available for other commissioned work. Contact Dave Wilcox at 3 Tarrandean Bungalows, Perranwell Station, Truro TR3 7NP.

'SSP 22' by Dave Wilcox

A modern technological subject, appositely tackled in a hi-tech medium. This image was designed on an A5000, using the PD program *Rayshade* (written in C by Craig Kolb and several colleagues, with the Acorn version implemented by Pete Goodwin).

To construct the image, Dave 'painted' a text description of a scene, comprising of 'Euclidean Lego' – spheres, cylinders, boxes, triangles, cones, irregular flat

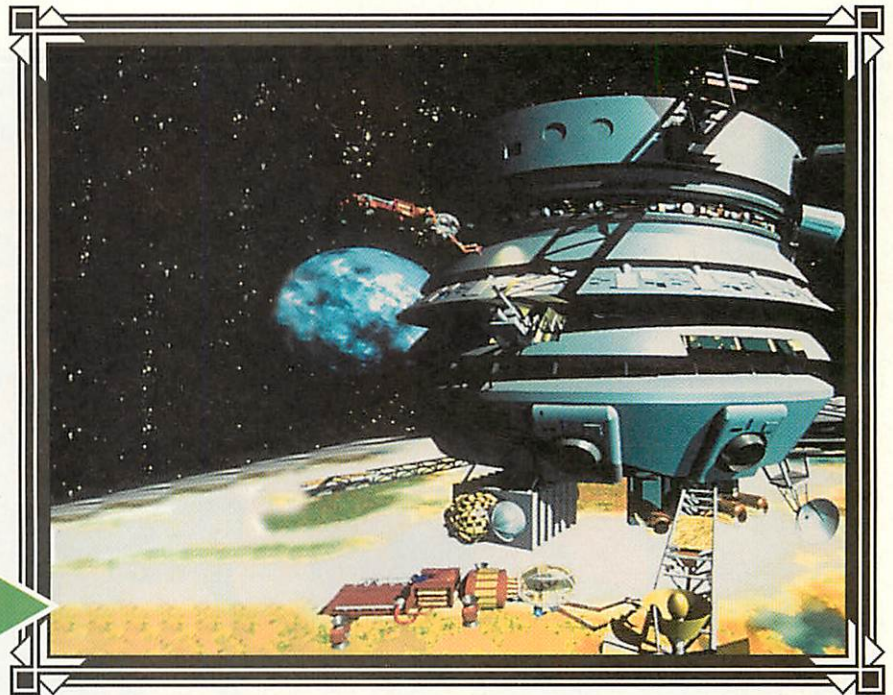

polygons, tori and so on. Each component was given colour attributes and textures, transparency and reflectivity. The final image was rendered in high resolution on a MEIKO parallel computer with 64 T800 transputers, to produce a fascinating image of startling clarity and realism.

Pete Clements

Although Pete's introduction to computer art occurred in the early '80s with the ZX81, it was the Archimedes that got him hooked. It wasn't long before he contributed his first computer image to *A&B Computing*, and began a long series of instructive articles on computer art in its many guises.

Today, Pete is able to write with some authority on the area of photo retouching, as he works for the BBC where he is in charge of Electronic Stills. There he works with a Power Mac, whose 'powers', he feels, have been eclipsed of late by the more intuitive feel of photo retouching software on the Risc PC. Pete has recently appeared on television in connection with his photo retouching skills, and in early 1995 is participating in an exhibition of computer art at the Workshop Gallery in East Molesey, Surrey.

'UFO' by Pete Clements

This is a chance for you to decide if the end result justifies the means. In this image, Pete has taken a scanned image and overpainted using *ProArtisan 24's* oil paint effect to provide a 'spooky' background. The spaceship is a digitised image of a model constructed from household items by Pete some time ago.

After placing the digitised image in position, Pete applied the lighting effects using an airbrush tool. The soft reddish glow was applied with an almost transparent brush. The overall effect is striking, and the composite image a neat demonstration of the skilled artist making good use of technological 'shortcuts'.



a well publicised image from a recent film and make a play on words and imagery with a medical twist. The original artwork was a tiny monochrome newspaper image. This was quickly scanned at low resolution using a hand scanner where it was ported into *DA's Picture*. Here, the opacity of the image was decreased to give a tracing paper-like effect and the halftone dots scanned from the print were smoothed out using the smear tool.

Once Jack was happy with the photo

retouched image, he sent the file into *Photodesk* where colour was added to the eyes and lips and the gun was carefully excised and replaced with a syringe through intricate use of airbrush and smear tools. The shadow was created in *ArtWorks* with a soft edge created using a simple blend between a white and black line of different thickness. Lastly the text was incorporated – a total time from start to finish of 60 hours.

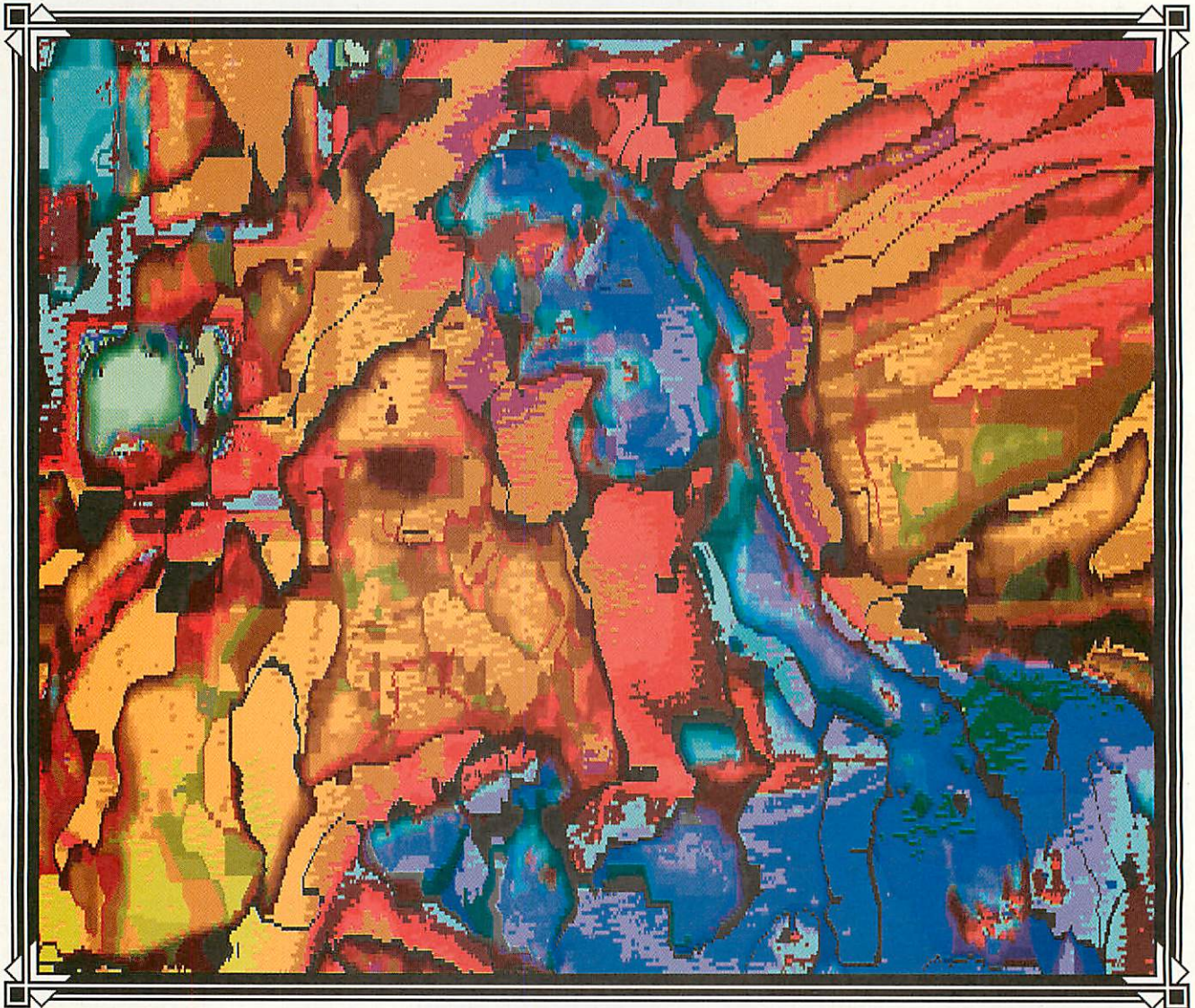

Pete Worrall

Pete's transition from real to virtual art came about in 1989, when he used an A310 to combine digitised and abstract images, a theme which he still pursues. He now has a collection of over 1000 discs of computer art at his Birmingham

home. Pete has exhibited extensively since 1991 and continues to do so 'despite the fact that many galleries in this country will not accept computer art as "real" art, or original'.

He is currently exploring Kodak Photo CD and says that while he has not

abandoned using real paper and paint, the possibilities in digital art excite him more and more. His ambitions include setting up a virtual gallery on the Internet. Pete will be staging a major retrospective exhibition of his work at the University of Central England in the summer of 1995.

Conclusions

It should perhaps be pointed out that all the artists contributing to this *Acorn User* gallery were given relatively little time to produce new artwork. Given the amount of time it can take to plan, construct and finish a piece of art to its creator's satisfaction, some preferred to offer existing material.

It is interesting to note that all the artists chose a modern or futuristic theme for their offering. And while this gallery of modern masters was intended to inspire our readers, rather than intimidate, I'll just open the doors to the debating chamber one final time by

repeating a quote from one of the artists above: 'Though the computer is a wonderful and versatile tool, producing fantastic special effects, it cannot produce artists.' I'll leave you to discuss it with your hairdresser.

Are you a budding Picasso? Will you be having your Acorn-generated artistic efforts publicly exhibited? Write to us giving advance notice of the dates and location, and we'll do our best to help publicise the event. And don't forget our Picture of the Month competition, where you can win £20 if we include your picture on the Graphics Page. Pictures on disc to the usual address, please.

'Feedback 32' by Pete Worrall

One of a series of 60 images created in 1991, this piece is typical of Pete's work, combining vibrant colours, the human form, and complex abstract overlays. It was created by colour-processing a rather dull digitised video image of the artist's daughter standing before a computer monitor, then overlaying patterns using a range of different software including Longman Logotron's *Revelation ImagePro* and Clares' *ProArtisan*.

The final effect is reminiscent of stained-glass work, and presents an interesting juxtaposition of life and movement with the harsh, inanimate nature of the machine.



HOW TO ORDER: Order by telephone quoting your credit card number. Order by post, cheques payable to "Technology Matrix".

EDUCATION ORDERS: Education orders are welcome. Please post or fax your official order for immediate attention.

TERMS: All prices exclude V.A.T. & carriage. Prices & specifications may change without notice. E. & O. E.



Technology Matrix

89A Stockport Road
Denton, Manchester
M34 6DD

FAX: 0161-320 3210

TEL: 0161-320 3087

ONE STOP STORAGE

Hard Drives

A3000/3010

_80MB 15MS IDE	159
120MB 15MS IDE	179
170MB 15MS IDE	199
250MB 15MS IDE	249
340MB 15MS IDE	289

A3020

_80MB 15MS IDE	109
120MB 15MS IDE	119
170MB 15MS IDE	145
250MB 15MS IDE	189
340MB 15MS IDE	239

The above Drives are complete with all fittings
A3/400/4/5000/RISC PC IDE

250MB IDE Drive	125
340MB IDE Drive	135
420MB IDE Drive	155

SCSI

250MB SCSI Drive	139
340MB SCSI Drive	159
540MB SCSI Drive	189
1.0GB SCSI Drive	439
2.0GB SCSI Drive	1169
4.0GB SCSI Drive	1829

SyQuest Drives

Denton SyQuest drives provide you with the ultimate hard disk storage - without imprisoning your data on a hard disk! Whenever you run out of storage space, simply eject the cartridge you've just filled up, and insert an empty one. It's that simple! Whatever your storage needs - transporting documents, archiving your files, or just keeping a copy of your data off-site for security reasons - Denton Removable SyQuest drives are the answer!

SCSI (internal)

_88MB 5.25" media	189
200MB 5.25" media	289
270MB 3.50" media	279

SCSI (external)

_88MB 5.25" media	289
200MB 5.25" media	399
270MB 3.50" media	389

IDE (internal) A5000/RISC

270MB 3.50" media	279
-------------------	-----

Cartridges

_88MB 5.25"	49
200MB 5.25"	65
105MB 3.50"	55
270MB 3.50"	55

Tape Drives

250MB Tape drive	495
500MB Tape drive	629
1.0 GB Tape drive	795
2.0 GB Tape drive	875

Supplied with cables, tape and software



Optical Drives

Fujitsu

230MB internal	479
230MB external	589

Sony

650MB internal	1495
650MB external	1589
1.3GB internal	1689
1.3GB external	1759

Cartridges

230MB cartridge	49
650MB cartridge	69
1.3GB cartridge	99

CD-ROM Drives

Cumana Oscar

209
Dual speed, connects to printer port on A3010/3020

Cumana Bravo

249
Dual speed, available with printer port connection or SLCD interface on A3/5000

Cumana Victor

Dual speed SCSI drive, available in single or six drive systems running at Quad speed.

420A Dual speed	289
632A Dual speed	399
602-6CD Dual speed	445
604-6CD Quad speed	845

Cumana Indigo

The ideal CD-ROM for the RISC-PC. The 300ia includes an audio mixer and Artisan 2 CD.

300i IDE interface	209
300ia IDE interface	249
401 SCSI interface	199
631 SCSI interface	299

I/O Cards

IDE

A3000/3010 series	69
A300/400 series	69

SCSI

A300/400 16 bit	85
A3/4/5000 16 bit	85
RISC PC 16 bit	85
RISC PC 32 bit	169

Graphics

Colour card gold	239
Chroma 500 Genlock	419
Chroma 150 PAL	169
Chroma Genlock card	209
Hawk V9 MKII Digi.	189
Eagle M2	319
Vision colour Digi.	99
HiVision colour Digi.	149
Scanlight video 256	199

Printers

Canon

BJ-10sx	153
BJ-200	197
BJ-230	279
BJ-600 colour	379
BJC-4000 colour	299

Hewlett Packard

HP320 portable	195
HP520 mono (NEW)	229
HP500 colour	
HP560 colour (NEW)	375
HP 4L (300dpi)	449
HP 4P (600dpi)	659

Monitors

Acorn

AKF52 14" Multiscn	249
AKF50 14" Hi. Res.	305
AKF60 14" Multiscan	315
AKF85 17" Multiscan	939

Sony

CPD-15SF1 15" Trinitron (Fantastic)	349
-------------------------------------	-----

IDEK

Vision Master 17" (Brilliant)	549
-------------------------------	-----

Denton

14" SVGA colour .28 pitch (good value)	169
--	-----

Accessories

50/50 way SCSI cable	15
25/50 way SCSI cable	15
SCSI 2 cable	25
SCSI terminator	15
2nd IDE drive fit. kit	10
External drive case	69

Memory

A3000 1-2Mb	call
A3000 2-4Mb	call
A3000 1-4Mb	call
A3010 1-2Mb	call
A3010 2-4Mb	call
A3020/A4000 2-4Mb	call
A5000 2-4Mb	call
A5000 8Mb	call
A300/A400 8Mb	call
RISC PC 4Mb	call
RISC PC 8Mb	call
RISC PC 16Mb	call

Computers



RISC PC 600

2/210 AKF60 14"	1155
2/210 AKF85 17"	1525
5/210 AKF60 14"	1289
5/210 AKF85 17"	1665
9/420 AKF60 14"	1569
9/420 AKF85 17"	1939

A3010 Action Pack (No Monitor)

FD system	245
_80MB HD system	399
120MB HD system	415

A3010 Learning Curve (No Monitor)

FD system	319
_80MB HD system	489
120MB HD system	505

A3010 Early Years (No Monitor)

FD system	329
_80MB HD system	499
120MB HD system	515

A3020 (AKF52 14")

FD system	689
_80MB HD system	799
120MB HD system	809

A4000 (AKF52 14")

210MB HD system	849
-----------------	-----

STAR BUY



STAR BUY

CALL FOR PRODUCTS NOT LISTED

CALL FOR PRINTERS NOT LISTED



TAOS beckons

Chris Mellor looks at Acorn, Amulet, Apple and ARM, and the future for them all.

The future for Acorn is not what it used to be. The Risc PC600 provides 486-beating performance but the Pentium is coming. RISC OS's ease of use advantage is also threatened by Windows 95, and the ferocious price competition in the PC market has made both Wintel – Windows & Intel – and Mac systems as affordable as Acorns. From mighty oaks little acorn bashers grow. How will Acorn cope?

Peter Bondar, product marketing manager for Acorn, referring to Clausewitz on war says that little armies can't fight big ones on a level battlefield: they'll get wiped out. They have to find smaller theatres and fight skirmishes they can win. The desktop is a big level battlefield and Acorn needs to get out of the line of fire. What is ARM doing that can help?

ARM's aims

According to marketing manager Trent Poltronetti, ARM's focus is the low cost, good performance, non-DOS compatible market. This is the processor profile needed by mobile phones, PDAs, and

smart cards. ARM is involved in partnerships developing smart cards, set top boxes, mobile phone processors and PCMCIA security cards. The market for such devices could be huge – total annual shipments of cars, telephones, colour TVs, VCRs, smart cards and wireless phones is 370 million. A ten per cent piece of that would be worth having and contrasts well with annual PC shipments of 45 million.

ARM sells to buyers who don't need desktop processor power, can't afford desktop power consumption levels and need small size. But desktop chips are moving from 5V to 3.3V operation and competition is bringing prices down. So ARM has to keep driving its technology hard to stay ahead.

Fortunately it has lots of headroom in

terms of clock speed, cache size, process technology, chip transistor budgets, instruction pipeline depth and on-chip parallelism. And the Amulet research project, outer blue sky in terms of actual chips, is quite promising. Figure 1 shows what has been accomplished already with the development of the ARM6 family from the initial ARM2. It also shows some of the roadmap to the ARM10.

ARM intends to maintain its niche advantage, avoiding head-to-head fights with Intel and PowerPC, and relying on architectural and process improvements to keep it ahead. Expect one such transition between ARMs 8 and 9.

Acorn's marketing strategy is also to introduce systems where Wintel is off its home base. Two possibilities

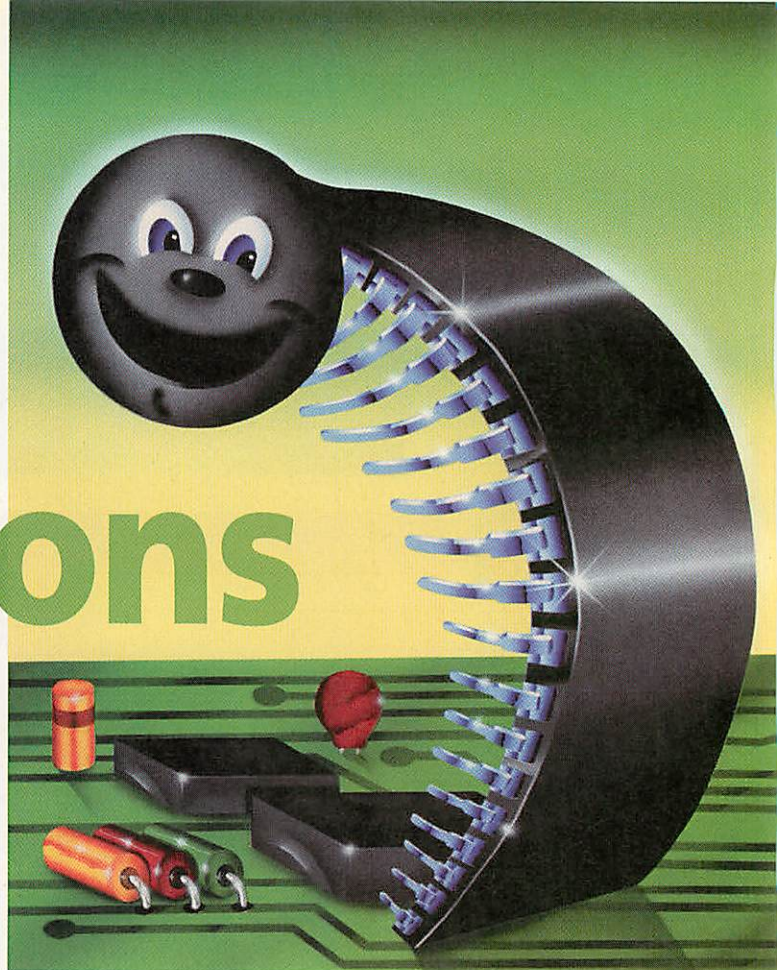
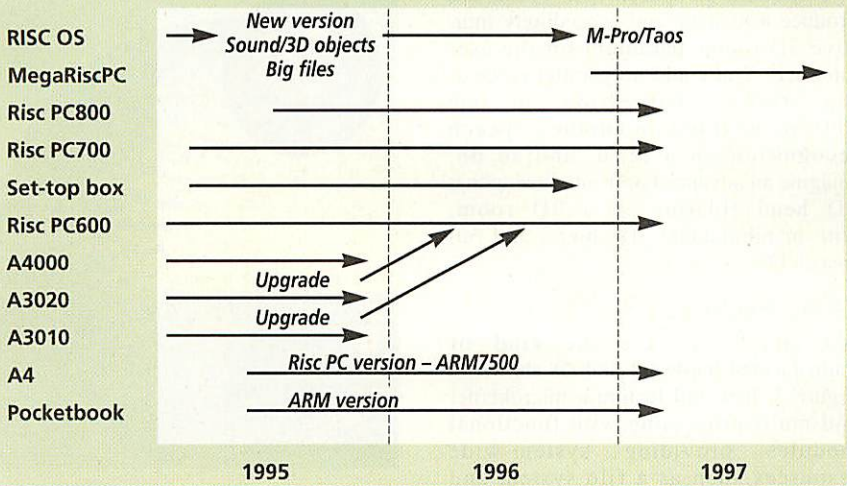

Figure 1: ARM Technology History and Roadmap. (*Italics show guesstimate numbers, not ARM statements.*)

	Clock (MHz)	Micron	Cycles /Instruction	Metal	Volts	Pipeline	Cache	DhryStone II MIPs	Kstones
ARM2	8	3µ		1-layer			None		
ARM250	12	1µ					None		
ARM3	25/33								17K
ARM6	30		1.9		5	3	4Kb		28K@20MHz
ARM610	25	0.6µ			5	3	4Kb		
	33	0.6µ			5	3	4Kb	30	
ARM7	20				3			18	
	33	0.8µ	1.8	2-layer	5	(3?)	8Kb	29.6	45K@30MHz
ARM710	25	0.6µ		2-layer	3.3		8Kb	23	
	40	0.6µ		2-layer	5	(3?)	8Kb	36	60K@43MHz
ARM8	60-70	0.35µ	1.4	3-layer	3	5		70?	120K@70MHz
ARM9	80-100		1	4-layer	2	5+	16Kb	100	200K@100MHz
ARM10	90-130		1.2				32Kb	130	

Figure 2: Possible Acorn Product Futures.
(Italicized text means indefinite maybes!)



here are one-per-child (OPD) and the set-top-box (STB).

The one-per-child sidestep

This is a magnificent example of wrong-footing the Wintel elephant. The idea is that every child should have a computer, something much more than a jumped-up calculator but affordable – a PDA for schoolkids. We're talking £200-£250 here, the price of a bike according to Acorn's product marketing guru, Peter Bondar.

As we know, Acorn went into partnership with Psion and offered the Pocket Book, a reworked Psion 3 Organiser, to schools. Acorn had designed its own OPD device using in-house hardware and software technologies, but cost and time-to-market considerations made it look for a development partner to speed things up, hence Psion. Various trials have been run under the auspices of NCET and these have been successful. Acorn's original sales projects were about right on the slow sales ramp, but a little off in the timing.

Current sales are looking good. The new Pocket Book II sold out within two weeks of its launch. Application software is coming along. There are around 25,000 junior and secondary schools in the UK. Assuming 200 children per school gives a market of 5,000,000: very attractive. ARM, Acorn and Psion are busy talking and the technology exists to bring the original Acorn OPD design into fruition. The current 16-bit NEC V30H 8086-compatible chip running at 3.84MHz could be updated to an ARM with ROM increasing to 1Mb – maybe beyond – allowing more capable applications. Mr Bondar would definitely not be drawn on the likelihood of a colour screen.

The schematic in Figure 2 shows a potential ARM Pocket Book appearing next

year (there is emphatically no commitment by Acorn to produce such a device). Acorn stresses that if a market needs someone else's technology for various reasons – it's already dominant, or Acorn's own would take too long to develop – then Acorn will work with partners, like Psion, and will work with the grain of the market and use the Acorn brand name which has a value separate from Acorn's own technology. In the education market – for example – Acorn's brand value is very high and could be combined with non-Acorn technology. The Risc PC 486 PC card is an example of this.

Suppose Acorn sold its software technologies such as the A-link, font manager and colour dithering algorithms. Could the Acorn brand make this marketable?

Arcs on the TV

The STB market is another emerging market, where the box enables home shopping services and video-on-demand to be fed to your TV in MPEG format. Acorn has spun off Online Media and is involved in a trial with Cambridge Cable. The next generation of the STB will be powered by the ARM7500, a highly integrated ARM710, together with 2Mb RAM, MPEG card, ATM card plus ROM and other bits.

ROM is important, as is the low power consumed by the ARM7500: you don't need a fan with the Online Media system. Peter Bondar says hard discs add to expense, increase unreliability, and you certainly 'don't want people inserting floppy discs and typing Alt-Del.' The OS is simple: 'We don't need any fonting WIMPs, it's just push button stuff.'

The competing Apple STB used in the BT Home Services trial is a Mac 68K system with a hard disc. They haven't got a ROM-able OS. He thinks that the ARM chip core could be integrated, in a couple of year's time, with the MPEG and ATM logic as

macrocells to create a one chip solution with a cost of around £50. Peter can't see how Apple can squeeze its Quadra-type solution into this cost territory – where the cable suppliers could virtually give STBs away à la French Minitel.

Such an integrated ARM chip, one with on-chip MPEG, ATM networking and other possibilities, would be useful in other markets, for example, schools. Peter is keen on the idea of recycling technologies and thus spreading the cost of development. The STB's ARM7500 could be used as the processor core for a Risc PC version of the A4; the technology could allow this to appear in 1995.

Education and the DTB clan

Acorn's traditional education market is undergoing a fast forward upset. Instead of selling to 2-300 educational advisors who set the policy for groups of schools, we now have local management of schools. Thousands of schools are taking input from their governors on IT policy, and the governors are, almost certainly, Windows users in their working lives. Acorn can sell on a one-to-one basis to a few hundred advisors, but no way can it cover the ground on a school-by-school basis. Acorn thinks the market will polarise into the pro-Wintel majority and a more discerning minority are appreciative of the benefits of Acorn systems as teaching tools.

So Acorn will concentrate on removing buying objections – the PC card, OmniClient, supporting the pro-Acorn buyers – the New Literacy campaign, and on working with the grain of the changing education market. One-per-child is an example of this.

What of the traditional Acorn users? The ones that bought a Beeb because the bangs-per-buck were phenomenal? Is there a market at all here? New Acorn engineering recruit Chris Stott, from UNIX company Santa Cruz Operation, reckons that a Wintel tidal wave is sweeping across the computing landscape. Once it's passed, not everyone will be bludgeoned into Windows submission. There will be a group of hold-outs looking for something more. Acorn's research reckons to have identified a possible 500,000 population of these holdouts – discerning technical buyers (DTBs) who will buy interesting computing solutions as early adopters. These are the people who are already in the Clan or likely to join it.

These early adopters are the market for Acorn desktop computers. Acorn will sell desktops to them and them alone, never to cross the chasm into mainstream computing. They would inter-operate with mainstream Wintel/PowerPC systems via disc exchange and networking, but that would be all. There is a sustainable and big enough market here for Acorn. What kind of hardware/software combinations

will these discerning technical buyers be interested in? What could Acorn produce for them? (Unless specifically mentioned, no Acorn commitments exist in this section by the way; it is all Bondar grade one blue sky theorising.)

RISC OS revamp

The 'don't go head-to-head' view means that RISC OS won't be revamped to compete directly against Windows 95. However, limitations on its ability to support devices will be removed. For example, if devices like a combined printer, copier, scanner and fax – the Xerox 3006 for example – become popular then support will be added. Peter described the 'Black' project to uprate RISC OS so that it can support storage devices in excess of 512Mb capacity. He specifically mentioned 4Gb IDE hard discs and 16Gb SCSI devices.

Peter said: 'We won't add 17 toolbars and 60 levels of menu.' Instead the main event would seem to be providing OS facilities and functions to complement technically interesting hardware coming in the future. Let's paint a possible hardware scenario.

The Mega Risc PC

A couple of ARM virtues are small size and low cost. Acorn could buy 30 ARM710s for the price of one Pentium. What could you do with 30 ARM710s

or 810s, 120 Dhrystone II MIPS apiece, an awesome 3600 MIPS of computing power?

You could do speech I/O. You could produce a realistic and exceedingly intuitive 3D rooms paradigm for the user interface. You could do parallel processing stuff – *Impression* on one CPU, networking on another, speech recognition on a third, and so on. Imagine an advanced user interface with a 3D head floating in a 3D room, with manipulatable 3D objects and full speech I/O.

TAOS beckons

We could envisage the kind of multi-faceted hardware and OS shown in Figure 3. It would feature a microkernel and multi-processing with functional modules providing system-wide resources such as a file system and networking. Candidate microkernels include TAOS (pronounced 'Dowos' – nothing is simple in anorak land) and the IBM microkernel.

There could be multiple OS personalities, with RISC OS and Windows being obvious candidates – here already with the Risc PC600 with PC card. There could be system-wide objects – 2D, 3D, sound and text – manipulatable by any OS personality, with an advanced user interface sitting on top of this melange of modularity. Could Acorn do

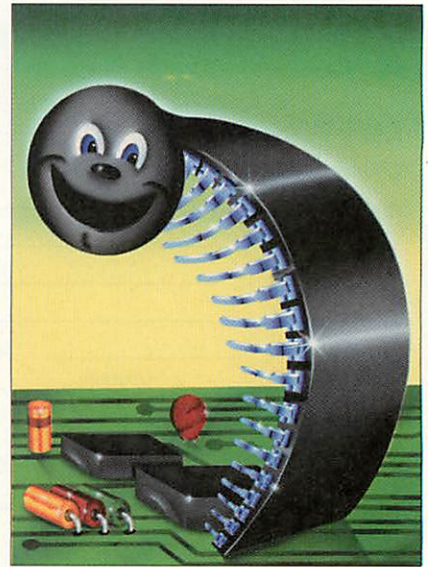

this? TAOS is a research project. The co-processor is here now. ARM810s are close. Peter thought that sound objects were a possibility for 1995 as were 3D objects.

Technologically, such an insanely great Acorn system would be 24-36 months away, and for a company with potentially devastatingly powerful technology combinations and obvious ARM710 and ARM810 product possibilities, Acorn is very silent about product futures. There is currently no plan and no budget for 'productising' any of these ideas. But the evolution path from the current Risc PC600 is there, it's not technically far-fetched and you can experiment with the various technologies as they appear using the current Risc PC platform.

Future shocks

There is a lot of excited mental arm-waving going on about ARM810s, multi-processors, 3D objects and the like, but nothing you can pin down – we could call it the application of TAOS theory to product development. Peter Bondar is a grade one technical guru, wears yellow socks and has pictures of wickedly powerful motorbikes on his office wall. We are not talking about your average company product marketing suit here. He is an archetypal Acorn enthusiast, Clan chieftain. But Acorn is a business first: it has to make profit, reliable dependable profit. At some stage it has to stop being in development mode and earn a living for its Olivetti parent.

The message is that Wintel will never provide both affordable and interesting computing. Neither will Apple. Both of these parties have their eyes fixed on the business and consumer computer markets. But Acorn, Risc PC sales permitting, Olivetti willing, cross your fingers for luck and toss some salt over your shoulder, might and very probably will.



Figure 3: Future System Nirvana.

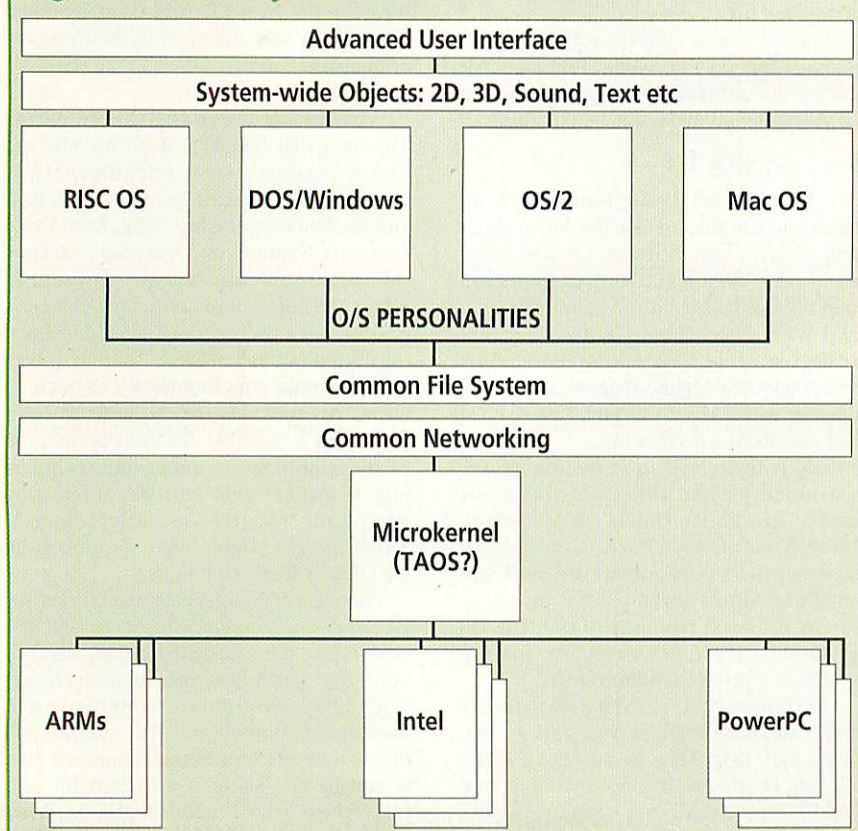

2 in 1
Quality
Colour
and
Black & White
Printer
from Canon



The Canon BJC-4000 and

RISC OS 3
Turbo
D R I V E R S

The BJC-4000 is unique new printer in the Canon range which offers both black and white and colour capability. It is designed to appeal to users who primarily print in black and white but who also have a colour requirement. Mono printing is extremely fast (about twice as fast as the BJ-200 on average) due to a special high-speed black ink cartridge and printing can be at a resolution up to 720 dpi using interpolation. However, it can also produce high quality 360 dpi colour prints. The inks have been specially developed by Canon for this printer and are fast drying and water resistant.

The printer is shipped with a BJC-4000 specific version of the new V4 TurboDrivers. Timing tests on a Risc PC indicate that the TurboDrivers still offer a significant speed advantage over the standard Acorn drivers, returning control and completing the print between 3-4 times faster for an average page. The TurboDriver software also supports advanced grey-component replacement, which prevents over saturation and produces more accurate colour reproduction.

The BJC-4000 is supplied with the Turbo-Driver V4 software (and DOS/Windows drivers), manual, printer cable and a set of colour inks for £369 + £10 p&p + VAT (£445.32 incl.) It is suitable for all models of Acorn RISC computer with RISC OS 3.1 or later. 4 MBytes and a hard disc are recommended. Available now direct from Computer Concepts.



Computer Concepts Ltd

E&OE. Details are subject to change.

Gaddesden Place, Hemel Hempstead, Herts HP2 6EX Tel 01442 63933 Fax 01442 231632
Email: Info@cconcepts.co.uk

There are two main requirements for large capacity storage apart from your computer's main hard disc drive. First of all you may need to archive files, for security backups or simply because there isn't enough main hard drive storage capacity. Secondly, you may need to send a large file or collection of files to somebody else, like a design studio or a print shop.

In this same feature, Jack Kreindler harks back to the days when a 2Mb floppy drive was an optional extra. Well, he's just a young upstart – I started out with 300 baud cassette tapes on an Apple II at the beginning of the last decade. In those days a floppy drive was lucky to hold 100K and to back one up to a cassette tape would take over an hour. Today we are spoiled for choice with fast tape drive systems and even faster high capacity random access disc drives of various types.

This article looks at all the commonly used options available today on all platforms, including those which aren't yet available to Acorn users, plus a look at what the future holds. Acorn users are restricted to a smaller selection of compatible storage options, usually because there aren't the necessary software drivers available yet. However, there are encouraging signs that more storage options are being supported natively on the RISC OS platform, while the growing availability of PC peripheral access through things like PC cards or parallel port interfaces

means Acorn users are less restricted than they used to be.

Magneto Optical (MO) drives were predicted to replace the humble floppy drive. That's still a long way from happening and it is more than a little disappointing that the cost of MO technology hasn't fallen faster than it has. A year ago 3.5in MO drives cost around £750. Today the standard capacity has moved up to 230Mb, but the price is still a hefty £600 and blank discs cost £50.

Price drop

In the same period, hard drive prices have halved. It actually makes some sense to back your hard drive onto another one but, unless you have a removable hard drive, MO has the advantage of supreme portability.

Syquest removable hard drives, popular in the print and publishing industry, have also dropped sharply in price; a 105Mb external SCSI drive is now about £330 compared with £500 a year ago, and the cartridges have almost halved in price to less than £40. Syquest and others have also brought out removable drives in tiny 1.8 inch PCMCIA form factors.

The dark horse

Staying with the rotating medium, CD-ROM is a dark horse. CD-ROM drives with a write-once recording facility (CDR) are dropping in price rapidly, though they

haven't yet breached the £1000 mark quite yet. If CDR drives follow the example set by their read-only cousins, we could see sub-£200 drives in just a few years time.

A UK company, Plasmon Data Limited, has teamed up with the people behind Panasonic, Matsushita Electric, to produce a re-writable optical drive which can also read CD-ROMs. The Plasmon PD2000 doesn't use MO technology, but phase-change re-writable optical technology. This uses a low-powered laser to toggle the spots on the recording medium which represent data bits between an amorphous (opaque) and crystalline (clear) state. No magnetic component is used, so only a single write pass is required. The drive is still expensive at £750, but if it catches on it will drop in price, and blank 650Mb phase change discs are quite competitively priced at £45.

Elsewhere, Fuji Film is drumming up support for its new 100Mb floppy disc technology, though whether it will succeed where 20Mb Floptical has failed will be another matter. Don't forget the perennial Bernoulli system from Iomega, either. These are 150Mb floppy drives which spin as fast as hard drives and use the Bernoulli aerodynamic effect to fly the read-write head over the spun-rigid magnetic disc. However, Iomega doesn't seem

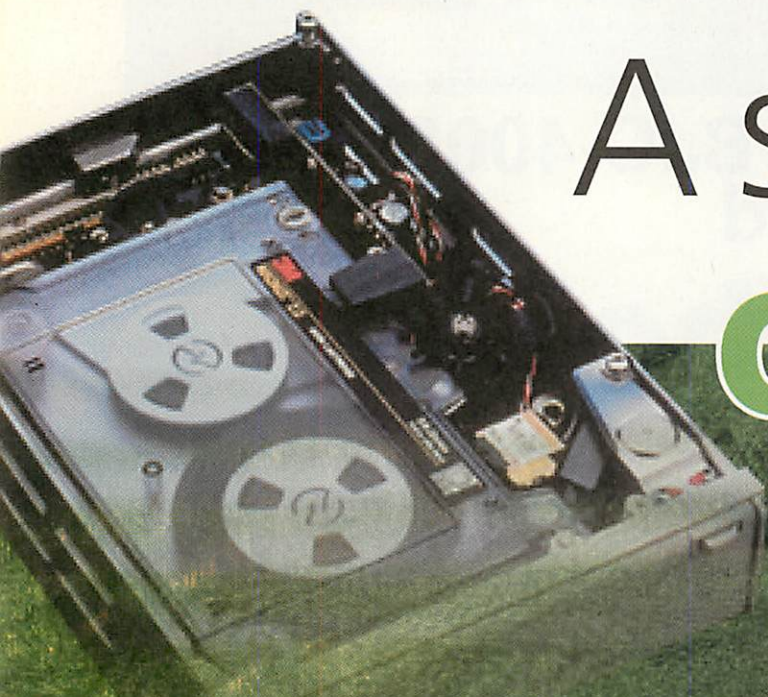

Two Gigabytes of storage on 290m of tape. This is fine for backup purposes, but random access is slow.

A surfeit of data

In these days of exponential growth of Information Technology, storage space for data is at a premium. Ian Burley looks at the technology behind high-capacity storage devices, and Jack Kreindler looks at which medium is best suited to which use.

able to reduce its prices as fast as competing media.

Tape capacity

Moving onto tape, there are several standards to choose from, depending upon your wallet and your needs. There is DAT, derived from digital audio hi-fi tape – compact and fast but still expensive – at £700 upwards. DAT tapes hold between 2 and 16Gb of data.

8mm, based on the camcorder video tape format, is even more expensive but has a higher capacity, reaching 100Gb per tape. At the more affordable end of the market is the DC range of tape streamers, the most common of which is based on the DC2120 tape with a 120Mb or 250Mb data capacity depending on the type of drive and compression system you use. External drives range from £150-£200. Hewlett-Packard, which last year acquired one of the leading DC2120-compatible drive makers Colorado, has just announced a revised compression scheme which boosts capacity by up to 50 per cent.

Just for a laugh, I worked out how many C60 cassette tapes I'd need to store 100Gb of data – the answer is a mere half a million or so, and it would take over a century to do the whole job.

Ian Burley

The good old days

Life was so much more simple in the days when a 2Mb floppy drive was an optional extra, and removable hard discs were the size of dinner plates and about as reliable at storing digital information as crockery. Demand was low for high capacity

storage devices, as only a very few professional users would require their data to be shipped around from system to system, and only large organisations and companies generated enough information to justify backing up onto tape.

Today, high resolution colour scanners, CD-ROM resources, ever more powerful DTP and graphics packages linked to advances in the hardware to utilise all these have greatly raised the amount of data running around the computer's bus and memory, together with the size of generated files. A typical page of a full colour magazine would consume around 25Mb once a few scans have been thrown in. To store and/or transport that kind of file requires a little more than 20 floppies and a backup program, especially when time is of the essence. Similarly, a large network can house hundreds of megabytes of new data and files generated daily, a change from the days when you could store a month's worth of word processing on an 800K floppy.

Storing data

There are two main areas of use for high capacity removable media – data storage and data transport. To take the former, options for backing up mammoth amounts of data have changed little over time; the most favoured medium is still tape technology, although 1, 2 and 5Gb hard discs have emerged, ranging from reasonable to utterly preposterous prices. These now offer a faster alternative if the backup

requirements are not cumulative.

The only significant change in tape-based systems has been the evolution of the tape streamer into the formidably high-capacity Digital Audio Tape – faster, smaller and sleeker than its analogue forerunner yet retaining a phenomenally low cost per megabyte storage.

Tapes can be used for transporting data from computer to computer, but their transportation ability is usually reserved for taking valuable data away from the source for security or safety purposes. Unfortunately there is no software bar the elusive PD program *Tape FS* which deals with tape-archived data in a random access manner. This is totally understandable as – unlike discs – tapes can only be written to and read from in a one-dimensional, 'linear' fashion. The most refined of Acorn tape streamer/DAT drivers still rely on downloading data onto hard disc from a text-based filer window for even the smallest of files to be accessed once archived. These systems make the familiar RISC OS filing system seem like a most gracious gift from the Ministry of Userfriendliness, and the issue is worsened by the fact that on most other platforms there are tape drivers which act in an emulated random access way with drag and drop implementation.

Even if Acorn software houses develop drivers which make opening files on tape a little less like opening a safe without a key, there will still be finite limits to the uses of tape-based media for data transport because of the speed of access times and



The fast and compact 3.5in Syquest drives that have recently become popular. These offer 105Mb and 270Mb storage capacities, and can be fitted to the 3.5in bay of an Archimedes in place of a second floppy drive.

The shape of things to come? The Plasmon PD2000 CD-ROM drive will also write 650Mb phase-change optical cartridges.

High-capacity storage devices

data rates. The access times for tapes are in the order of minutes as opposed to a typical hard disc's millisecond benchmark. In time-critical situations like the production of a magazine, hundreds of megabytes must be sent from computer to imagesetter, with countless minute changes made to the files once proofed. These pedestrian access times, combined with a data rate of no more than a double-speed CD-ROM for the top of the range DAT drives could cause more than a minor irritation.

Drives themselves are a little expensive, ranging from a couple of hundred pounds for a tediously slow tape streamer to over a grand for a range-topping 4Gb DAT drive. If you are a bone-fide data creator, a large network or company, then DAT (as opposed to conventional tape which is rapidly becoming obsolete) would be a good choice. Cost is of little consequence after the initial investment for the drive, as 2Gb will set you back £10 or thereabouts. However, for regular access, storage and transportation you would be infinitely better off with a random access device.

Take-away data

Random access removable storage media are essentially a hybrid of the floppy and hard disc, or at least a combination of the philosophy behind the two media. The hard drive is a fast, high capacity, internal device where speed and room are the issues. The floppy is a convenient way of storing, transporting and backing up data. The synthesis of these technologies resulted in the creation of a number of products.

The 'floptical' was designed to be a novel floppy with a capacity of around 20 times that of a HD disc – it is essentially an ultra high density floppy disc. Working optically, these devices are faster than floppies but fall quite short of the speed of an old IDE hard drive.

Floptical did not take off as it was heralded to, and the market soon became swamped by the already established 'Syquest' technology. Syquests are based more on the hard disc than the floptical and, apart from their bulk, the Syquest's vital statistics are more impressive than the floptical. Today's Syquests are only a whisker slower than a standard 160Mb internal IDE and come in a range of capacities from 44Mb to 270Mb. Interestingly the modern 3.5in drives are



The SQ5200C, a state-of-the-art 5.25in Syquest drive which can read and write 44Mb, 88Mb and 200Mb Syquest cartridges.

higher capacity than the antiquated 5.25in units which make the 44Mb and 88Mb discs popular with DTP and graphic design houses.

The 128Mb and 270Mb discs are small and fast but remain a little expensive at £70 to £80 (depending where you shop) for a 270Mb disc. The drives cost from £200 to £400 and are a universally accepted medium in the reproduction industry. My only worry about Syquest is reliability. I once wrote a 20,000 word short story which I backed up no less than four times on a Syquest before I sold my old computer, but when it came to re-installing my archived data onto my new machine, all four copies had been corrupted irretrievably. Thank goodness I made a laser copy – but it still involved a lot of unnecessary key presses before I was back to square one. This was not an isolated incident and though less critical, the occasional file does get corrupted on the Syquests I use.

Magneto optical discs

Finally we come to the Magneto Optical disc or 'Mo' as I am told it is known among hard-core data shifters. Magneto Optical drives look like CD-ROMs but are very different from the CD in that they are re-writable. They are as fast as a hard disc in reading but slower at writing. This is especially so when writing bitmaps, though they are not slow enough to be noticed in general usage. MO discs are impressive little things, especially the 3.5in discs which look and feel exactly like a conventional floppy from the outside, if perhaps a little thicker. The only discernible difference is the 230Mb capacity rating printed on the front, a tad less restrictive than 1.6Mb one feels.

You can pick up a 230Mb MO drive for about £500, if you look around, with a disc chucked in for free, and providing your SCSI card can manage 'optical memory' devices, then costs remain low. A single 230Mb disc is £30 a go, about a tenth of the cost per megabyte than internal hard discs, and for the price you have got fast and cost-effective archiving, with mobility and security advantages over a conventional hard disc. Like Syquests and other random access devices the MO works just as if it were another hard drive. Before buying I would check with third parties as to whether a standard magneto optical device can be read by their SCSI cards, as the Acorn card for the Risc PC can't read them – now that was a bit of a shocker.

Conclusion

It is important that you get your requirements sorted out before choosing which removable storage medium you choose to purchase; is it storage, transport or both? If you are just duplicating your hard disc and security (in case of robbery etc.) is not important, then consider a second internal hard disc; it will work out cheaper. If you require backing up alone, for regular, permanent archiving then DAT is the way to go.

For all other needs my choice is the Magneto Optical disc. With new 384Mb floppy sized discs and drives (and 650Mb CD-ROM sized) on the market, this fast, reliable and cost effective medium presently stands at the cutting edge of removable storage technology, and may possibly become the replacement of the floppy disc. The only problem is that you might find that the discs get lost among your mountainous piles of floppies. All of mine have.

Jack Kreindler **AU**

Contact details

Digital services	Tel: (01705) 210600
Cumana	Tel: (01483) 503121 Fax: (01483) 451371
Acorn Computers Ltd	Tel: (01223) 254254 Fax: (01223) 254262
Morley Electronics	Tel: 0191-257 6355 Fax: 0191-257 6373

It's time to
get *sensitive*
about the way
you *create*
your graphics

Many computer users feel that a graphics tablet is more natural to use than a mouse and without doubt it gives a much faster, smoother and higher resolution response. The mouse remains functional and can be used at the same time as the pen — however the pen has such a natural and precise feel, you will probably prefer it for many operations such as moving windows, drag and drop, region selection etc.

The new (approximately A6) ArtPad tablet offers a superb specification, even by Wacom standards; resolution exceeding 2000 dpi, 200 samples per second and 256 levels of pressure. All Wacom tablets include a cordless pen for added ease of use and flexibility.

The tablets are pressure sensitive, so in combination with suitable applications they can produce realistic effects such as variable width (the Eesox ArtWorks pressure sensitive tool) or variable density airbrush painting (PhotoDesk). The Computer Concepts's drivers will be compatible with these and other software that can take advantage of the pressure information, such as Studio 24 and DA Picture.

Computer Concepts can supply the tablets with either Photodesk or the Eesox Pressure Tool at special prices. **PHOTODESK** is a photo retouching package from Spacotech, which offers a wide range of advanced image manipulation features; for example an airbrush, paintbrush and magic wand, full 24 bit colour support, the use of virtual memory, OLE with Impression, complete undo, effects such as colouring, toning and masking, motion blurring, cloning and smudge and smear.

The package contains the Wacom tablet (A6 ArtPad, A5 or A4) and manual, a cordless pen, Computer Concepts driver software suitable for all models of Acorn RISC computer (A3000 must have serial port upgrade) and PC drivers. Requires 1Mbyte or more.

Price: A6 ArtPad & drivers: £169 + VAT (£198.57 incl.) A5 tablet & drivers: £399 + VAT (£468.82 incl.)
A4 tablet & drivers: £549 + VAT (£645.07 incl.)

ArtWorks Pressure Tool with tablet: add £10 + VAT (£11.75 incl.)

PhotoDesk with tablet: add £125 + VAT (£146.87 incl.)

ArtWorks Pressure Tool: £39 + VAT (£45.82 incl.) PhotoDesk: £169 + VAT (£198.57 incl.)



Computer Concepts Ltd

It's ironic to think that one of the most important products Acorn will bring out this year, which is indeed crucial to help preserve Acorn's proprietary RISC OS world, is a plug-in upgrade to make a Risc PC compatible with IBM PC software. There have been other such solutions before, from Acorn's own initially impressive, but ultimately out-moded *PC Soft* emulator to Aleph One's comparatively expensive PC-on-a-podule expansion cards. Even though we only have an issue one pre-production version of the new Risc PC 486 card plus fragile prototype systems software, it can be confidently said that Acorn looks like getting it right – and its solution is so much cheaper and elegant than those on other non-PC platforms, like Apple, for example.

In the beginning

In the Spring of 1993, when the Risc PC was in the early stages of being born, Acorn made that crucial decision to provide an option to enable users to run *Microsoft Windows 3.x* software, if necessary, in an acceptable manner. The word is that Acorn first consulted Insignia Solutions, who developed the notable *SoftWindows* emulator for Apple. *PC Soft*, Acorn's own software emulation of an Intel 80186 processor, was showing its age, but as we were eventually to find out when Apple launched the Power Mac range last Spring, even Insignia could only manage to emulate an 80286 level processor. For efficient *Windows* operation you need an 80386-level processor, complete with its enhanced memory management capabilities on which subsequent 486 and

Cuckoo in the nest?

Ian Burley takes a first look at the 486 second processor for the Risc PC.

Pentium designs are closely based.

In the Autumn of 1993 it was clear that a hardware solution was the only choice, but Aleph One's PC Podules were expensive and seriously hindered by the relatively slow 16-bit podule interface bus. Finally, the decision was made to go for a dual-processor architecture, enabling an alien processor, like a 486, to sit alongside the original ARM RISC processor.

The end result is a card slightly larger than the native ARM610 daughter card, containing a low voltage Texas Instruments' 486SX clocked at 33MHz. At the heart of the card is a custom ASIC (Application Specific Integrated Circuit) designed jointly by Acorn, Aleph One and Future Technologies in Scotland. It's called Gemini – an earlier design was referred to as Sheena – and manages any access the 486 processor requires to the Risc PC's main system bus (Open Bus),

and looks after a second level write-back 128K processor cache. It also looks after the 486's own external bus, contains a keyboard controller, some timers and a four word 32-bit data write buffer.

More than nine out of ten PC manufacturers buy off-the-shelf control logic chips analogous to the Risc PC 486 Gemini chip. It's a tough job to design one, which is why only specialists tend to bother these days. The sheer effort Acorn, Aleph One and Future Technologies have put into the design is certainly atypical of the companies behind most PC brands on the market today.

The software

On the software side, a modified Aleph One PC Podule application program has been developed to provide the PC environment – memory allocation, DOS boot, video display driver, peripheral and interface management, etc. Indeed, there is still plenty of software emulation of a PC going on in the background.

The accompanying *PC Configure* application from the old PC Podule card has been retained in an enhanced form. This

Comparisons of the various systems

PC Comparisons		Risc PC 486	Apricot Xen LSII	Archimedes A440/ 1 Aleph One 486/ 25MHz Arm3	Gateway 2000 Handbook 425
PC Memory		8Mb	8Mb	8Mb	4Mb
CPU		33MHz 486SXL	25MHz 486SX	50MHz 486SLC2 (16-bit external)	25MHz 486SX
Disc cache		32-bit file access, 2Mb VCache	32-bit file access, 32-bit disc access, 2Mb VCache	32-bit file access, 2Mb VCache	32-bit file access, 1Mb VCache
Windows User Processor	Higher is best	4.5	7.3	7.3	6.9
WU Memory	Higher is best	4.4	8.1	5	7.6
WU Graphics	Higher is best	8.2	6.6	3	4.3
WU Hard Disc	Higher is best	10.7	13.6	6.4	8.1
WU Windows	Higher is best	6.4	7.7	5	3.6
WU Overall	Higher is best	6.5	8.4	5.1	5.8
Landmark 286 MHz	Higher is best	81.2	83.6	141	83.8
Landmark DOS character	Higher is best	153	4866	66	1627
Dhrystone 1		8620	12195	7463	12500
Dhrystone 2		10000	15625	9090	16129
Price (assuming Archimedes already purchased)		£99 + VAT	£899 + VAT	circa £670 + VAT	£699 + VAT

lets you create DOS hard disc partitions which can now be as large as RISC OS hard disc partitions rather than just 32Mb which they were originally restricted to. It also gives you the option of starting the PC environment in full screen, window or RISC OS icon mode.

From here you can also choose whether you want to direct printer output via the RISC OS printer stream. It wasn't possible to test this, though we are told by Acorn it will be possible to print from DOS and Windows (with Windows printer drivers) to supported printers. Calligraph says that it is confident Acorn will modify RISC OS *!Printers* to enable it to produce a printer driver for its direct laser controller system, but Computer Concepts was less positive about the possibility of getting *LaserDirect* or *TurboDrivers* working from Windows.

PC Configure also lets you choose the amount of main system memory you choose to let the 486 have access to for applications and the display. Here it hits home how greedy Windows is for memory. 4Mb is a recommended minimum, 8Mb is comfortable and 12-16Mb is optimum. Those figures are over and above what you need for RISC OS, so it would be just about impossible to run a 4Mb Windows session in a 4Mb+1Mb VRAM Risc PC. A 6Mb PC mode, with 512K for video, is about the maximum safe configuration for an 8+2Mb Risc PC. Running a 16+2Mb Risc PC enabled us to configure a 12Mb PC, which is a nice all-round size, while retaining some useful RISC OS applications space.

Performance

Aleph One's original PC podules, which used 16-bit 'SX' rather than faster 32-bit external bus versions of 386 or 486 processors, were really miniature PCs all in their own right, with their own memory and interfaces, basically using the host Acorn machine to deal with the display, mouse, keyboard and some I/O ports. Aleph One even developed a *Windows* graphics driver to use the power of the host machine's ARM processor to accelerate graphics operations under *Windows*.

The big drawback was the slow and narrow Podule Bus which crippled screen updates, made worse on Archimedes without the luxury of VRAM, which got slower if bigger and more colourful screen modes were used. The Risc PC, with its faster native processor and unhindered VRAM screen memory option made the old-style cards more acceptable to use, but performance still couldn't honestly be compared with a real PC. Even the last-gasp 50MHz 486SLC Aleph One podules remained sluggish compared to the real PCs, and of course they cost a lot of money.

The new Risc PC 486 would be completely unhindered by a slow bus, in fact when installed it masters the Open Bus and gets the same access to memory and

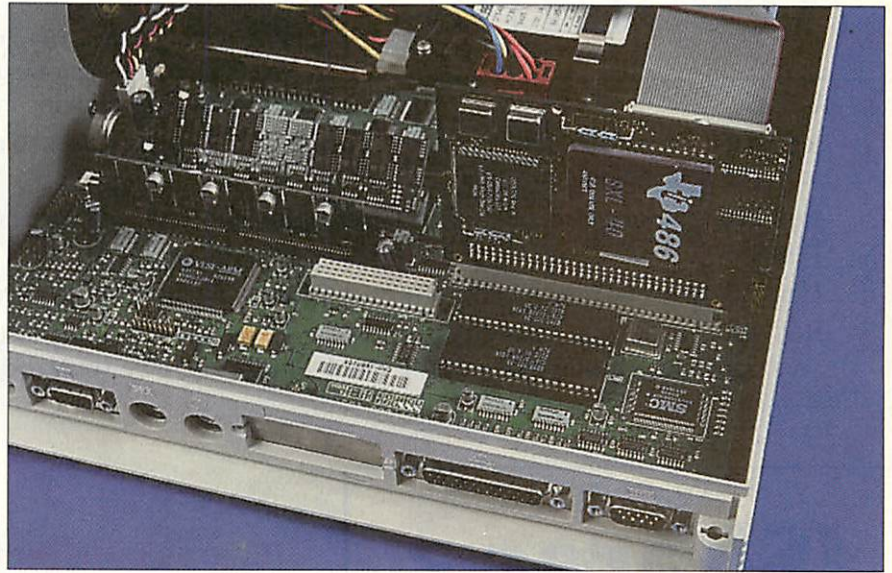

The PC card fits neatly into the second processor slot in the Risc PC. Note that because the 486 chip dissipates a much larger amount of heat than the ARM chip it must not face the other card, or the ARM chip could overheat. The cards can therefore only be inserted one way round.

peripherals as the Risc PC's native ARM processor. Acorn chose a full 32-bit inside and out 486 processor and this has an 8K on-chip instruction cache. The TI486 used is a 32-bit SX version without on-chip floating point maths and, while it is rated at 40MHz, it is only clocked to 33MHz. The signs are that Acorn will stick with this chip for the first 10,000 486 cards but for really fast 486s like DX2, DX4 and even Pentium variants, you will have to wait to around the middle of the year at the earliest when a new improved version of the Gemini ASIC arrives.

Unfortunately, the first Gemini ASIC release has some frustrating limitations which are to be fixed in the Mk2 version. The most serious of these is a memory access problem which can reduce memory access speed by half in some situations. Acorn's own figures indicate that memory writes only work half as fast as a real PC, though reads are more efficient at 80-90 percent of real PC speed.

Then again, Acorn says integer arithmetic performance is identical to an equivalent PC, though our integer dhrystone benchmark tests indicated that a comparable PC can be 50 per cent faster. Aleph One explains that even the dhrystone test will be affected by memory access restrictions because the Risc PC's Open Bus architecture is optimised for 8 and 32-bit memory writes, while the 486 usually generates 16-bit writes which are handled much less efficiently by the memory caching system.

Usability

Windows benchmarks give a confused picture of the Risc PC's 486 performance. Acorn demonstrated an Apple Power Mac 7100 running *SoftWindows* which gave a ridiculously higher benchmark result than the Risc PC 486, even though it took more

than twice as long to complete the test. We've included some benchmark figures for academic interest, but the real message is that the Risc PC 486 is really very usable, much more so than the old Aleph One PC podules. We'd bet many users of real 25MHz and 33MHz 486 PCs will probably not notice much difference between these and a well-configured Risc PC 486. Hard disc and graphical speed really determine perceivable performance in PCs, especially under Windows, and the Risc PC performs quite well in both these areas.

Noticeable areas where the Risc PC falls down are when the floppy disc is being accessed – the Windows mouse gets very jerky – and outside of Windows ordinary DOS character mode screen update speed is quite poor for a 486 system, though not disastrously so. Acorn says there is potential to alleviate both these issues with software enhancements as development continues.

We were also able to run Aleph One's *PCNet* ethernet driver to hook our Risc PC Windows system into a Windows for Workgroups network without problems. Accessing a Cumana SLCD internal IDE CD-ROM drive was problem free as well. In fact, multimedia animation driven from CD-ROM under Windows is quite respectable too.

To summarise, for £99 + VAT, which includes IBM PC DOS 6.3 (but not Windows), you can't really complain. It performs more like a 25MHz 486 PC than its 33MHz specification, but there are loads of people very happily using much slower PCs than this. Acorn should be congratulated for delivering such a cost-effective and elegant solution, especially when Apple's idea of hardware-based PC compatibility costs five times more. The first production run of the cards should be available in April. **AU**

Personal Accounts

Version 3 of Personal Accounts takes personal and club accounting to a new level of user-friendliness.

With 24 accounts, 184 analysis headings, direct 'live' entry & editing into fully scrolling windows, full undo & redo, automatic standing orders (for income and transfers as well as payments),

automatic forecasting, full import & export, drag & drop, user definable reporting and a whole host of other features, Personal Accounts V3 is a must.

Reviews: "Personal Accounts is a winner, you'll probably wonder how you ever coped without it" - **Archimedes World**

"This has to be the benchmark bank account software for RiscOS" - **Archive**

"No other personal accounts program can compare when it comes to entering, editing and visual presentation of your accounts" - **a summary of the many letters we have received from satisfied users.**

£49.95 inc.

!Shares 3

!Shares3 was written specifically for people who need a simple stocks & shares portfolio program.

But this does not imply it is lacking in features. It can handle up to 60 companies in a single file (you can of course have as many files as you need). Your share prices can be updated whenever you like and most types of transaction are handled including bonus shares, part paid shares and scrip dividend issues amongst others.

!Shares3 also includes graphs, export and import and extensive reporting features.

Now accepts data direct from DesignIT & Computer Concepts TV tuner/teletext card.

£39.95 inc.

Prophet

The small business accounting system for all Acorn computers*. As featured in Acorn User's recent Best Business Software Review.

Prophet is used by over 700 people in the UK to run their businesses more efficiently and is approved by UK Customs & Excise for VAT purposes.

Prophet is also used by many book-keepers and accountants (no limit to the number of company accounts) and increasingly by many schools and other UK institutions (free site licence available).

Features include multiple bank accounts, 192 analysis headings, VAT (including Cash accounting), invoicing, quotes & estimates, credit notes, delivery notes, statements, purchase orders, stock control, automatic standing orders, user definable reports, mail merging, profit & loss, balance sheet, tax calculations and of course full editing of ALL your data.

Above all though, Prophet is aimed directly at the non-accountant, so if you need to computerise your accounts Prophet will not baffle you with jargon.

(*requires minimum of 2mb ram)

£199.75 inc.

Apricote Studios

2 Purls Bridge Farm, Manea, Cambs, PE15 0ND

Tel/Fax: 01354 680432



A good judge of character

Ian Burley scans some text into his machine and tries to read it with *Sleuth 2*.

REVIEW

It's exactly a year since we last looked at the *Sleuth* optical character recognition (OCR) package from what was then Risc Developments. Now sold under the Beebug banner, *Sleuth 2* is faster, has an automated spell-check option and can understand many more fonts. Our tests show it is a vastly superior package to its predecessor, though this has resulted in a doubling in price.

Like before, when you run *Sleuth* a small application icon installs itself on the icon bar, onto which you can drag a previously scanned sprite image file for translating. Now you can also scan documents straight into *Sleuth* via David Pilling's TWAIN universal scanner interface utility, though you have to obtain this separately.

Both *Sleuths* can ignore certain visible and control characters, but with *Sleuth 2* you also get speed versus accuracy choices. There are three levels of accuracy: careful, medium and quick. Word-checking is provided in two stages: context checking – called form-only – to determine how sensible letters are in relation to each other in a word, and a full spellcheck at the end of the OCR process. If selected, the spell option will automatically replace words it thinks are wrong; there is no manual checking option.

With the default options (medium plus full word check) selected in *Sleuth 2*, you can get consistently good results in just

two thirds of the time you can with *Sleuth 1*. Switch to quick mode and you can more than halve the processing time compared with *Sleuth 1*, and you can save further time by switching the word checking off.

Table one shows the results of some speed comparisons for *Sleuth 1* and *2*. Even though Rockwell still isn't listed by *Sleuth 2* as a recognised font, using full word checking it managed 100 per cent success on our test paragraph, only falling over on a portion of the alpha-numeric sequence section. *Sleuth 2* managed better Rockwell results than *Sleuth 1* in just over a quarter of the processing time. *Sleuth 2* now recognises nearly a hundred Electronic Font Foundry fonts from 24 families, including many oblique, italic and bold variations. However, there is still no training facility.

So far, so good, but there was disappointment when testing a faxed document. Admittedly, this is a very tough test for any OCR package and few on any platform have great success dealing with the low-resolution images faxes deliver. Even with faxes sent in fine resolution mode, *Sleuth 2* could only correctly recognise a handful of characters, far too few for the word checker to get to grips with. It's a shame, as converting fax documents is probably one of the most useful of potential applications for OCR. *Sleuth 2* probably fails here because fax characters

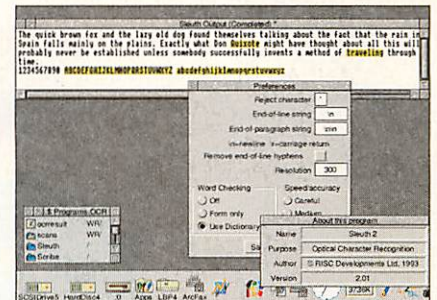

Sleuth 2 now highlights words it is unsure about after the OCR process.

often have 'broken' characters with pixels missing here and there, which is simply made worse when re-scanning.

Sleuth 2 now gives you a progress indication while it is processing. Once completed it will highlight any text it isn't confident about, and there is a Rich Text Format (RTF) export option which can match text sizes with the original document. *Sleuth 2* needs much more memory than before and has to cache data to disc. Alas, *Sleuth 2* no longer works in just 1Mb RAM.

To conclude, anybody already using *Sleuth* should seriously consider upgrading to *Sleuth 2*. Good quality scanned text in a wide variety of classic serif and sans serif fonts will OCR very well, but no sheet feeder support is a serious omission for heavy users and there is no obvious way of automating the processing of a batch of pre-scanned documents. It is also irksome to have to pay the same price you might have originally paid for *Sleuth 1/1.5* for just the upgrade to *Sleuth 2*. It seems to mark the end of a popular policy of aggressive pricing from Beebug. *Sleuth 1.5* has risen 20 per cent to £59.99 while the *Sleuth 2* upgrade price is £49.99. **AU**

Table one: Sleuth comparison test results (10Mb Risc PC)

<i>Sleuth 1.03</i>				
Font	Time (Sec)	Overall Accuracy	Text accuracy	Words/min
Courier	80	99.3	100	45.8
Trinity	85	100	100	43.1
Rockwell	126	95.1	97.6	29.0
<i>Sleuth 2</i>				
Font/preferences	Time (Sec)	Overall Accuracy	Text accuracy	Words/min
Courier/medium/spellcheck on	50	99.0	99.8	73.2
Courier/careful/spellcheck on	65	99.6	99.8	56.3
Courier/quick/spellcheck on	30	98.8	99.8	122
Trinity/medium/spellcheck on	54	100	100	67.8
Trinity/quick/spellcheck on	40	100	100	91.5
Trinity/quick/spellcheck off	29	96.6	95.9	126.2
Trinity/careful/spellcheck on	76	97.3	96.8	48.2
Rockwell/medium/spellcheck on	51	97.1	100	71.8
Rockwell/careful/spellcheck on	74	97.5	100	49.5
Rockwell quick/spellcheck on	36	96.8	100	101.7

Product details

Product: Sleuth 2
 Supplier: Beebug
 Tel: (01727) 840303
 Fax: (01727) 860263
 Price: £99.99 + VAT

Pros: Much improved speed • Textual accuracy with word checking
 Cons: No sheet feeder or batch processing support • No learn mode • Price hike

FUTURE ROLEPLAYER

The New Magazine For Roleplayers



If you're a roleplayer and own a PC then you simply cannot be without Future Roleplayer

Issue 1 features:

- A full roleplaying system
- A free disk offer

There are also articles, features and reviews covering all aspects of the computer roleplaying hobby. An informed news section brings you all the latest info on what's afoot in the industry.

And all this for just £1.99

To order your copy now send an SAE with cheque or PO for £1.99 to:
Future Roleplayer, New Frontier Publications, 8 Woodsetts Road,
North Anston, Sheffield, S31 7EQ

Anyone who saw Keith Chegwin in Harrogate last year won't have forgotten him. Especially if you saw the crowd in the theatre all blow raspberries at him at the same time – even more entertaining than *The Big Breakfast*. This year's even better on the celebrity front: we've got two!

Dominik Diamond

Remember the first Harrogate show in 1993? On the Saturday our special guest was Dominik Diamond, and if you need a lesson in madcap games commentary, look no further. We even did a Moxon Interview on him – that was quite an experience.

Well, Dominik is back this year, on the Saturday. He's aged a little since – he's 24 now – and he's more popular than ever. He's most famous for presenting Channel 4's massively popular programme *Games Master*, making him one of the most important games reviewers in the market. *Games Master* is on its fourth series, and goes from strength to strength.

Not content with success on terrestrial television, Dominik has also produced *Games World* on BSkyB, and has a regular games spot on BBC Radio One. He also presents *Fantasy Football*, *Sportscall* and *Newscall* for Radio Five, has written two books and has a monthly two-page column in the *Scottish Daily Record*.

In 1993 Dominik was most impressed

with the Acorn games scene – let's hope he's even more enthusiastic this year.

Violet Berlin

If you're into watching children's television in the afternoon – be you at school, a parent or a lazy student – then you'll be familiar with *Bad Influence*, the computer games programme. Violet is co-presenter of the programme, and with a large audience and three series already made, it's proved to be a big success.

Proving her enthusiasm for all things computer gamesy, she's also moving into satellite television with a spin-off series, *Bad Level 10*, and contributes to the Channel 4 teletext magazine *Digitiser* – check it out if you have teletext.

Violet has also had considerable success with *Head to Head*, a challenge show she devised for The Children's Channel. In fact, *Head to Head* is the highest rating programme on the channel, and similar success is expected of *Cheatflash*, her latest project.

Violet will be visiting the show on Sunday, so if you're into games, you can

Remember Keith Chegwin at last year's Acorn User Spring Show? Well, we've gone one better this year, and have two famous personalities to entertain the crowds. Read on...



be guaranteed great celebrity games chat on both days.

The theatre

Not quite as famous, but just as important, are the presenters in the theatre, including the staff of *Acorn User*. We'll be publishing the full theatre programme next month, but here are some of the highlights.

On the educational side, Sherston, Longman Logotron, Oak Solutions and Anglia TV will be demonstrating the best in educational software, and if music is your thing, Sibelius Software will be there to show you the best music editor in the world. Clares will also be in the theatre, but its range of software is so big, we can't tell what it'll be covering.

On the games front we have VTi, Krisalis and Gamesware, and if you are graphically minded, Spaceteck will be there with the latest version of *Photodesk*. Of course, Acorn will be demonstrating its latest products, and Computer Concepts will be showing off anything from its huge range of products.

So, if you want to see the best in Acorn gear, and rub shoulders with the famous in the games scene, don't miss the *Acorn User Spring Show*.

How to get tickets

Tickets are priced at £5 for adults, £2 for children (under 16) and £12 for a family ticket, which will admit two adults and up to three under 16s. The show is open from 9.30am to 5.30pm on each of the two days, and is in Hall C of the Harrogate International Centre.

You can obtain tickets by writing to Safesell Exhibitions Ltd, Market House, Cross Road, Tadworth, Surrey KT20 5SR: cheques should be made payable to Safesell Exhibitions Ltd. If you want to buy your tickets by credit card, then you can do so by ringing the credit card hotline on (01737) 814713: both Visa and Mastercard are welcome. **AU** See you there!

Spring celebrities

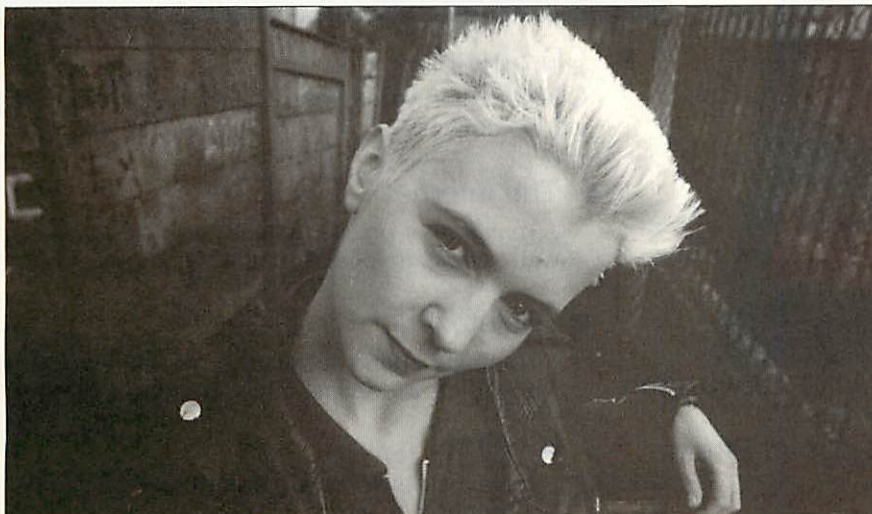

Cumana NEXUS

A network for all Acorn schools

Primary - HARD DISC SHARING OF APPLICATIONS

- No management - as simple as a hard disc
- A3000 compatible - breathes new life into old machines
- Secure - applications are protected by a keyswitch
- Easily upgradable - CD and printer sharing can be added
- Robust - linked computers cannot interfere with each other
- Cost effective - low cost primary option now available

Secondary - SITE WIDE NETWORKING

- Easy management
Nexus networks and workstations are self-configuring. A simple but powerful boot application makes customising the system very easy
- Robust
Any network failure has a limited effect. Advanced management software makes faults easy to locate
- Fast application serving
Application servers come as standard with a Nexus system. This greatly reduces the load on network file servers
- Compatible
Only Nexus networks offer full connectivity to the whole range of Acorn computers. e.g. BBCs and MDFS
- Modular
Nexus networks can grow from a small cluster serving a single department to a full school network

The world - OF INFORMATION

- CD Sharing
CD-Net 2 software allows CD ROMs to be shared via the network
- The Internet
A mail server on the network provides every workstation with access to local e-mail and the global Internet
- Teletext
Teletext serving software provides fast access to any teletext service, including foreign broadcasts
- ATM
Nexus networks are based on the same ATM technology which will provide the high-speed, multimedia networks of the future

NEXUS ATM networking has been designed to meet the specific needs of UK education.

Nexus systems have been developed to deal with the heavy demand for applications, datafiles and print services that occurs at the beginning and end of lessons.

Nexus systems require little or no management, leaving teachers free to teach.

A school's investment in networking needs to last. Nexus systems use industry standard Category 5 cabling which will also support high speed ATM networking in the future.

For more information on Nexus ATM networking and approved dealers please contact:

Cumana Ltd, Pines Trading Estate, Broad Street,
Guildford, Surrey GU3 3BH

Tel: 01483 503121 Fax: 01483 451371

Cumana CD-ROM for all Acorn users

● Double-speed, Kodak Photo CD compatible ●

Risc PC.....the fastest computer from Acorn

Indigo - OPEN THE COMPUTER "AND IN-IT-GOES"

- Easy to fit using the computer's IDE interface
- Built-in audio mixer
- ProArtisan 2CD-ROM Edition, Acorn PhotoView and audio player software
- Stereo headphones

ProArtisan 2CD
includes a FREE
Photo CD disc

£249

**Risc PC, A5000, A4000, A3020, A3010, A3000, A540,
A400, A300 and A4**

Bravo - WILL HAVE YOU CHEERING

- Rugged case doubles as a monitor stand
- Built-in audio mixer
- Cumana Photo Album Photo CD, Acorn PhotoView and audio player software
- Stereo headphones

Prices include
vat and delivery

£299

Note: Bravo drives for A3000, A540,
A400 and A300 are supplied
with single width expansion card

Risc PC, A5000, A4000, A3020, A3010 and A4

Oscar - A HARD ACT TO FOLLOW

- Connects in seconds to the printer port
- Spare connector for printer, dongles and/or a second CD-ROM drive
- Cumana Photo Album Photo CD, Acorn PhotoView and audio player software
- Stereo headphones

£249

Up to
31st March '95
free Speedy-CD
with every Indigo
purchase!



Up to
31st March '95 free
PC driver software
with every
Bravo & Oscar
purchase!

I would like to order an _____ drive
at £ _____ including delivery & vat
(UK mainland only)

- TICK ONE
- I enclose a cheque for £ _____
(payable to Cumana Ltd.)
- Please debit my MasterCard/VISA
credit card (please delete)

No

Expiry date _____

Signature _____

My Acorn computer is a (state model) _____

Please rush me my personal copy of
the new Cumana CD-ROM Portfolio

Please tick this box if you wish to
receive future product information
from Cumana

Name _____

Address _____

Postcode _____

Telephone No. _____



Cumana Ltd, Pines Trading Estate, Broad Street, Guildford, Surrey GU3 3BH. Tel. 01483 503121 Fax. 01483 451371

These special offers are also available through Acorn
dealers and are subject to availability

Join these crazy characters on a raucous romp through wierd worlds and spooky spaces in a platform adventure game from the creators of the acclaimed Top Banana.

BIG BANG

PSYCORE
PO Box 3837
London NW3 1JF

Big Bang is available on either a 1.6mb HD disc or two 800k DD discs at **£14.95 inc.**

Why DO people buy from THE DATA STORE?

We're an Acorn specialist – no other brands of computer to distract you.

A large stock of hardware, software and peripherals, all on demonstration if required.

Friendly, knowledgeable and efficient service – in person or by mail/telephone order.

Finance terms available (subject to status, written details on request) including six months interest-free on selected items.

BARGAIN BASEMENT: a selection of older software at 50 to 75% off for a limited period.

Free parking right outside the shop.

Bromley's AMAZING SUB-TROPICAL CLIMATE! (only joking)



We accept:
Visa
Diners Club
Mastercard
Switch.

6 CHATTERTON ROAD, BROMLEY, KENT BR2 9QN - Tel: 0181-460 8991 - Fax: 0181-313 0400



Oddball

ScreenShots

Oddball is a bat and ball game on a massive scale! Oddball means stunning action and puzzles on a huge scrolling playing area. There's a wealth of features including power ups, bonus levels, teleport pads, electric arcs, moving blocks, variable gravity, full game load and save, fast parallax scrolling (50 frames per second on a RISC PCI), and eight channel stereo sound and music. Best of all, the price is only

£8.95

To order, send a cheque or postal order for £8.95 to: **Digital Psychosis, 14 Madingley Road, Cambridge CB3 0EE.** Phone (01223) 329070

Asylum, an addictive platform shoot-em-up game, is still available for £7.95. You can also buy Asylum and Oddball together for the special price of £14.95. Both games work on all Acorn RISC OS machines, including the RISC PC, with 1MB of memory or more. Unfortunately we are unable to accept credit card orders.

GAME SHOW

Well oops, pardon me for speaking out. It would appear that my comments about packaging and presentation have angered a few of the 'in' crowd – that is those who have seen it all, done it all and now preach it all. Many, in fact most of the angered, have taken my comments completely the wrong way and interpreted it all as an attack on budget or PD software. Nothing could be further from the truth. I have nothing against free or cut-price software.

My comments were based upon the attitudes of those funny little people called the consumers (those who buy and play the games) who shared a few choice words with me at the recent shows. I'm not talking about a handful of punters either – I wouldn't be so stupid as to 'speak out' without

sufficient backing. It appears that there are mixed feelings about the PC revolution and what it is going to do to the cuddly Acorn market. Some see it as a gateway to the fantastic world of games that dozens of PC magazines enthuse about, while others seem more concerned as to whether any of the existing programmers and developers will continue in a market that will have to be shared with multi-million dollar firms.

I mean, I played a game the other day on a PC that had real actors in it, ones I recognised too. I can't really see that happening in the near future for an Acorn-native game. To compete on level terms, albeit with the advantage of already having a foothold in the market, it also seemed a unanimous decision that the presentation – that is the box-art and

instructions – could do with some slight improvements in many quarters.

I know many do it all for the 'love', and it is a bit tight to criticise them, but if you aspire to be the best, look and act the best. There are many doing just that and I could name five games companies that are already standing up well to the challenge that awaits. I won't name them – they know who they are as they are making money, and I'm sure they 'love' that too.

I wonder what the next show will bring up? Perhaps we should attack the floppy disc design – I've never liked that, all square and boring.

Already next month is shaping up with a full review of *Face to Face* (previewed this month) and a little something called *Oddball* from Digital Psychosis. They were a little reluctant to send it to me but if it helps, the

box is fine. (It plays well too.) Next month...

Good news for *Dune II* fans as well – I've completely finished the game. All of it. I must say it fills me with a great sense of loss that my spare moments will no longer be spent grabbing spice and testing new strategies. I might publish a complete solution or rather handy hint guide soon, but first I shall leave enough time for this best-seller to frustrate a few more people. I've also nailed *Wolfenstein 3D* with some rather impressive percentages.

The April edition will carry some rather important changes and allow me to introduce the new reviewer who is going to join me in the quest for a better game. For those in the know it is an obvious choice, for those not... watch this space!

Steve Atherton

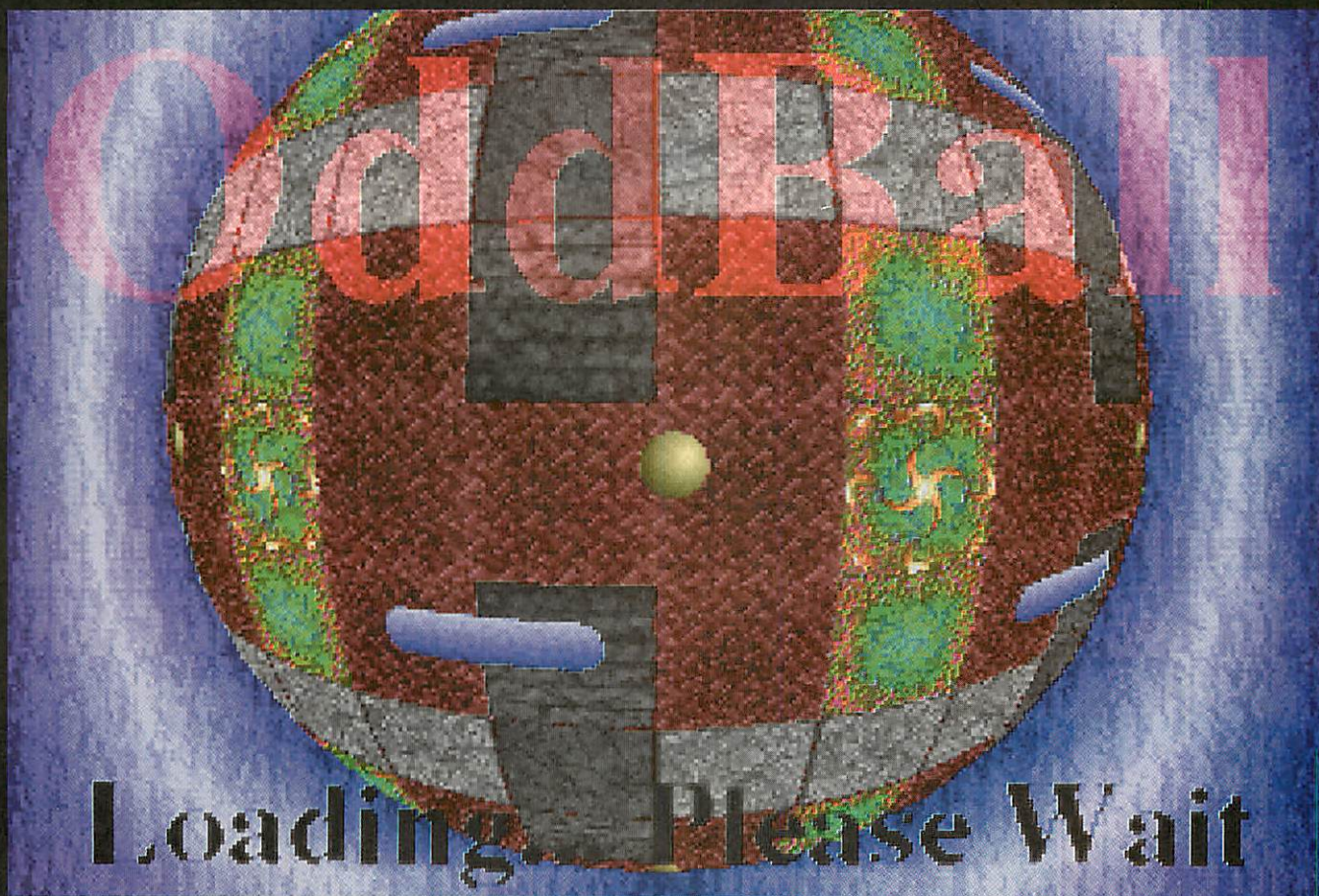

Just arrived and to be reviewed next month – *Oddball*, and it's a 'Budget' game. Nice box, graphics look good, but will I like it?

Supplier: Oregon
Tel: 0121-353 6044
Price: £24.95 + VAT

First impressions count for a lot in the games market, and the first impression given by the box for *Sally and Wally* is encouraging. Phrases such as: two-player mode; hard disc installation; over 100 levels of furry animated fun; Rise PC compatible all leap out and say 'buy me!'

If I picked up the box for this offering the above list would satisfy my initial questions and I would read on with interest. The game seems to have it all: cute main characters, a nice colourful box and even the option of two-player simultaneous play. However, what the box fails to convey is the biggest selling point of the entire game: this game is aimed in the main at kids.

The target age appears to be about six to 14, with the older bracket having more than a passing interest. I

Sally and Wally

guess it is up to games reviewers like myself to point this out before the average *Dune II* or *SimCity 2000* user takes it home and feels insulted by the slightly more simplistic gameplay. With no clue on the box I fell for the trap immediately and felt like putting the game back in the cellophane and leaving well alone. However, the

press release caught my eye and all was revealed.

The eponymous Sally and Wally are two lovebirds who, after returning from their honeymoon, find that the home they had planned to spend their council tax on has been struck by disaster. In true

Wildlife on One style the warm, wet and bacteria-ridden environment is now host to bugs, nasties and some horrible creepy crawlies. Sally is understandably upset and refuses to make dinner. Wally comforts her and while ushering her towards the comforting environment of the cooker, washing machine and ironing board, sets about his mission to remove the gatecrashers. Should two people wish to play the game then Sally shuns her responsibilities and stands by her man with equally deadly consequences for the insects and bugs.

Before embarking on the quest, the option is available to control the volume of the sound effects and music as well as defining the gameplay keys. Once this is done you can save the result for another day - now how many

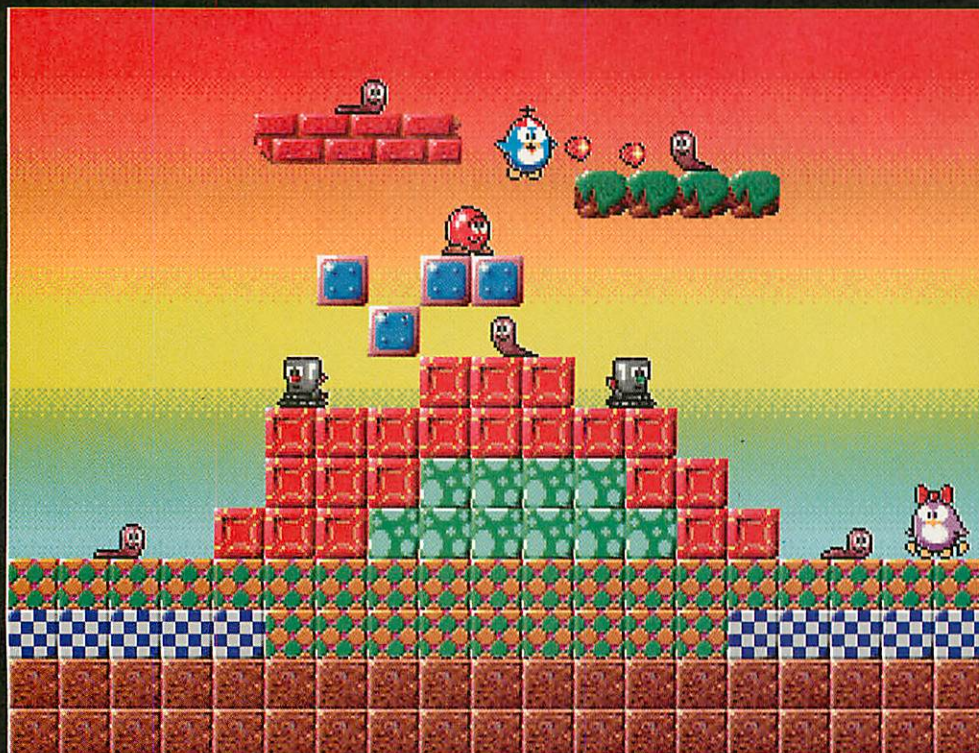

Flutter around guiding your character from platform to platform, shooting all that moves. These cute little worms seem to be oblivious of the fate that awaits them. Throw a ball of herbicide and wipe that smile from their faces.



To finish a level you must first wipe out the baddies. To give you a fighting chance there are plenty of power-ups to collect, including this rather fetching suit of armour. Don't forget to run over the stunned insects and find that exit!

games do I know that could really do with a set-up like this?

Once all is set up and saved for future reference, you can begin playing in earnest. As I said, this is a game for the younger players among us and with this in mind, I think I can safely say I had a lot of fun. Although many might say the edge has

been taken off the challenge, I found that I could relax more and not feel quite so intimidated by the whole affair. All the intro screens are great fun and do the job of setting the scene and explaining your task ahead.

There is a nice little touch in the level selector screen which is in fact a huge palm tree. This does make sense,



Things could not be easier. Just highlight the leaf you require and a corresponding level will be chosen. It goes without saying that certain later levels will require you to enter a password or two...

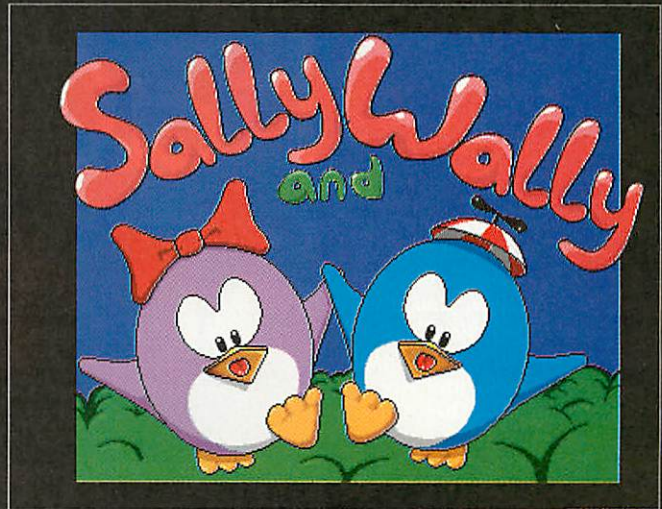

So our two little lovebirds are off, their one simple task in hand to rid their new house of all the creepy crawlies that mother nature has decided to throw at them. Sit back and enjoy some 2000 screens of mayhem. Do it for the kids!

believe me. Included as well is the option of using passwords to motor around the 100 levels of the challenge. Bear in mind that this is a necessity as each level in itself has 20 screens, so that makes a sum total of... err... 2000 individual screens to conquer. Now kids, that is value for money, so mum and dad should be more than convinced to buy you a copy of the game.

The actual nuts and bolts of the game are also simple, yet demanding enough to be interesting. Guide the character or characters through the platforms throwing balls of insecticide at the creepy crawlies. As one of these special balls of poison hits the enemy it freezes for a few moments and allows you to collect him for dinner – you see, there is always a positive aspect to pest control. Even the very structure of the game has not been spared the Oregon touch as you start to notice odd things happening to the little bird as he/she

passes over certain blocks. It turns out they have differing properties, with some providing a slippery surface, some only allowing one way of travel and others even exploding when a ball is thrown in their direction.

Once the entire level has been cleared of the nasties it's time to exit. This is done by returning to the large EXIT area and pressing jump. Before you know it, it's time for another level.

I can sum this game up succinctly by saying that it is huge fun. I found it great to play and no doubt a younger gamer would get even more out of it. I'm afraid the albatross that these targeted games tend to be lumbered with is the question 'does it have any educational value?' The answer, to be honest, is not much, but hey! who cares? It will keep them quiet and off the streets. Let's face it, parents don't need an excuse for playing, so why should kids?

Steve Atherton

Supplier: SYRAsoft
Tel: (01452) 750128
(evenings)

I mentioned this offering a while back after the Acorn Show and – judging by the press release – those little details that always seem to creep up at the last minute did their duty to hold up the launch until now. Based on the *Simis Flight Sim Toolkit*, the game is set in the summer of 1940 and accurately depicts the finer moments of the Battle of Britain. You can fly either a Spitfire or Hurricane in battle with a traditional Biplane – the Tiger Moth being used for training. I won't give this the full review treatment this month because the game arrived quite late in the schedule and I would like to do all it justice. What I'll outline here are the basics, with just a smattering of hands-on experience.

The ground detail is accurate and portrays the southern shores of Britain, with a few compromises. Thirty missions lie ahead and

Face to Face

– believe me – some skill is going to be needed if you want to teach the Hun a lesson or two. You start as a Flight Cadet and must graduate up through the ranks. The first task ahead is to pass the initial flying exam in the Tiger Moth, with judging based on aerobatics, plane control and ground operations. Medals and sudden promotion can also be obtained through bravery in combat. How all of these feats of aeronautical derring-do are judged is beyond me, but it all ends up on a pilot's record and looks great on the

headstone after kissing the ground at full throttle.

Before a pilot can even start the motor a more than passing acquaintance needs to be made with the controls, so consult the rather in-depth manual until it all seems clear. There are so many controls to select it gets a bit bewildering at first: to let you into a little secret, I kept stabbing 'N' to hopefully centre everything, only to find the next keystroke made my pilot bail out (quite a feat let me tell you, especially at 50 feet). For those of you spoiling for a fight, the

game has a time acceleration mode which lets you cover ground and events at great speed – just the thing if you have the scenery detail on low and want to mix it up with the enemy as quickly as possible.

Real aircraft fans will be overjoyed at the cockpit instrumentation, with radios, hydraulics and even oxygen all catered for via dials, buttons and lights. In combat it soon lights up like a Christmas tree, and when I tell you there are varying degrees of battle damage to obtain, you will appreciate that a good pilot (or at least a confident one) is needed to win through.

Never is confidence needed more than in the landing stages; this is when it all comes together or falls apart. I remember many a flight sim getting the thumbs down from being too difficult to handle in these crucial stages. I can't comment right now on how easy things get with this one because I've not been too successful as yet in returning home safely. However, I can detect signs that it might be something to do with bad hand-eye co-ordination and not programming (OK, I know that's the problem).

All in all, *Face to Face* looks like a very professional offering with tons of gameplay. It has just the right level of impossibility to make you go up for more, time and time again. The game is certainly very accurate in both scenery and aircraft renditions, and I can't wait to explore in more depth.

Steve Atherton



Even before you've got off the ground in *Face to Face*, you have to contend with a dashboard full of controls and indicators. This is certainly an improvement on the displays of many flight simulators around, even if it doesn't make actually taking off any easier.

Late Night Opening
Wednesday & Thursday
Until 7:30

Open Sunday
11 to 4pm



FIRST COMPUTER CENTRE

HOW TO ORDER DELIVERY TARIFFS

Order by telephone quoting your credit card number. If paying by cheque please make payable to: "FIRST COMPUTER CENTRE". In any correspondence please quote a phone number & post code. Allow 5 working days cheque clearance.

SHOWROOM ADDRESS:
DEPT. ACU, UNIT 3, ARMLEY PARK
COURT, STANNINGLEY RD, LEEDS,
LS12 2AE



#2% surcharge on Amex

- Software standard delivery £1.66
- 2-3 Week Days £2.51
- Next Week Day £4.21

Per order, not per item.
Delivery subject to stock.

- Please add VAT @ 17.5%
- Large showroom with parking
- Multi-million pound company
- Overseas orders taken
- Educational purchase orders welcome

OPEN 7 DAYS A WEEK

Mon - Sat 9:30 - 5:30 Sun 11 - 4
Please check our latest prices before ordering.
All sales are subject to our standard terms & conditions (copy available upon request). E&OE.

10 LINES!
Telephone 0113 2319444

24 HOUR MAIL ORDER SERVICE FAX: 0113 23 9191
NEW! BBS Modem sales & technical line Tel 0113 2311422

AUTHORISED REPAIR CENTRE

We offer a FREE quotation on your Acorn or any peripheral (monitors, printers etc). A delivery tariff of just £5.00 is charged or alternatively you can visit our showroom. We can also arrange a courier pickup at an additional cost of £11.00.

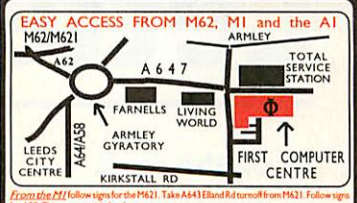

From the M1 follow signs for the M62. Take A641 Eland Rd turnoff from M62. Follow signs for A58. This merges with Amley grassy.
From the A1 take the turnoff for the A64. This merges with the A58 (by-passing Leeds town centre) which meets the Armley Gyrotory.

New Risc PC

Includes Free 12 Months On-Site Maintenance

- Prices Listed are for Cash, Cheque or Credit Card #
- PC600 2Mb HD210 £1199.00
complete with Acorn AKF60 monitor
 - PC600 5Mb HD210 £1294.00
complete with Acorn AKF60 monitor
 - PC600 5Mb *without monitor £1123.40
complete with Acorn AKF60 monitor
 - PC600 9Mb HD420 £1594.00
complete with Acorn AKF60 monitor
 - PC600 9Mb *without monitor £1416.00
complete with Acorn AKF60 monitor
 - With 17" AKF85 add £388.00
 - PC Card 486sx (When ordered with a RiscPC) £99.00
* Enthusiast Scheme purchase without monitor.

ARCHIMEDES

SPECIAL OFFER!
OLIVETTI JP360 COLOUR
INKJET ONLY £69.00 WHEN
YOU BUY AN A3020 OR A4000

- A3010 Action Pack £249.00
Includes Start Write (Wordprocessor) & Zool
- A3010 Early Years £330.00
- A3010 E/Yrs & AKF52 £493.00
- A3010 Learning Curve £330.00
- A3010 L/C & AKF52 £493.00
- A3020 FD £685.00
complete with Acorn AKF52 monitor
- A3020HD60 £825.00
complete with Acorn AKF52 monitor
- A4000 HD £865.00
complete with Acorn AKF52 monitor
- 12 Months On-Site Maintenance £25.49
- Early Years £42.00
Pack contains Start Write (Wordprocessing), Talking Stories Doris the Dotty Dog, A Mouse in Holland, Explore with Flossy Frog & Paint Pot
- Learning Curve Pack £42.00
Acorn Advance , PC Emulator & Dr-Dos
- Home Office Pack £85.00
Easewriter, DataPower, Pipedream 4, PC Emulator & Dr-Dos.
- Pocketbook II 256 £222.00
- Pocketbook II 512K £272.00

We Operate Acorn Assist
0% finance available
(Teachers / Lecturers or Concerned Parents)

SOFTWARE

Application Software

- Arc Comm 2 £46.00
- Arc Fax 1.12 £29.79
- Arcterm 7 £56.50
- Artworks 1.54 £120.83
- Firework £99.00
- Hearsay II £67.50
- Home Accounts £27.00
- Impression Style £74.50
- Impression Publisher £130.00
- Nighsky £61.23
- Pendown Plus £65.50
- Pro Artisan 24 (Risc PC Only) £129.00
- Rhapsody 3 £73.50
- Rhythm Bed £36.50
- Render Bender 2 £38.00
- Serenade £77.02
- Schemata 2 £94.00
- Talking Pendown £53.00
- Titler £77.00
- Turbo Driver B/Epson/HP £40.00
* Please Specify Printer
- Twin £17.02
- Vox Box £38.26
- Wordz £75.00

Educational Software

- 10/10 Dinosaurs £16.50
- 10/10 Driving Test £16.50
- 10/10 Early Essentials £16.50
- 10/10 English £16.50
- 10/10 French £16.50
- 10/10 Junior Essentials £16.50
- 10/10 Maths (Algebra) £16.50
- 10/10 Maths (Numbers) £16.50
- 10/10 Maths (Statistics) £16.50
- 10/10 Spelling £16.50
- Badger Trails £33.50
- Chrystal Rain Forest £32.77
- Fun School 5-7 £18.00

Fun School 7-11 £18.00

- Fun School 4 Under 5 £18.00
- Naughty Stories V for II £37.50
- Noddys Playtime £16.50

Entertainment Software

- Birds of War £22.70
- Black Angel £22.70
- Break 147 / Superpool £22.70
- Cannon Fodder £16.70
- Carnage £16.50
- Crystal Maze £27.83
- Cyber Chess £22.70
- Diggers £27.50
- Dune II £29.97
- E-Type 2 £29.78
- Elite £18.30
- Flashback £20.00
- FTT Formula 2000 £16.50
- Haunted House £18.70
- Lemmings More (RiscPC) £16.70
- Magic Pockets £18.68
- Play it Again Sam II or III £17.20
- Premier Manager £20.42
- Sally and Wally £22.70
- Saloon Cars Deluxe £17.50
- Sensible Soccer £19.50
- Scrabble £28.00
- Sim City 2000 (AS000/RiscPC) £27.80
- Simon the Sorcerer £22.55
- Star Fighter 2000 £22.70
- The Dungeon £21.00
- The Real McCoy 2.3 or 4 £16.50
- Time Machine £21.27
- Virtual Gol £20.50
- Wolfenstein 3D £20.50

Books

- Wimp Program for All £12.50
- Basic Wimp Prog. £14.50
- With Examples disk £16.50
- BBC Basic Manual £19.50
- Beginners Guide to Wimp £12.50

CD Software

- Artworks £129.00
- Artworks Clipart £18.00
- British Birds £150.00
- Cars-Maths in Motion £50.00
- Creepy Crawlies £47.50
- Dictionary/Living World £47.00
- Exploring Plant Sciences £85.00
- Goldlocks £39.00
- Grany's Garden £30.00
- Grooves £36.00
- Map Skills £49.00
- Multi-Media Encl £149.00
- Image Warehouse £45.00
- Interactive Periodic Table £96.00
- Intro to Classical Music £48.00
- INVENTORS & INVENTIONS £150.00
- ITN European Atlas £144.00
- Oxford Reading Tree £39.00
- PDCC 1 (99% Risc comp) £28.09
- PDCC 2 (99% Risc comp) £25.53
- Photobase Landscapes £47.50
- Pro-Artisan 2 £127.00
- Space Encyclopedia £32.00
- Understanding the Body £43.99
- World War II Archives £144.00

SIBELIUS 6

Music Processing System
£134.00

Complete Midi System
with Yamaha PSS51 61 Keys
Mini Keyboard (100 Voices, 28
Note Polyphonic), Ideal for
Composition
Midi Max & Midi Cables
£367.00

Full size music keyboard
Yamaha PSR83add £30.00

We also stock a very large range of
PC DCS which can be run on
machines with a PC Card

PRINTERS

All our printers come with ribbon/toner, paper & cables!!

Canon

- Canon BJ10sx £157.44
Laser quality output. Large buffer
- Canon BJ200 £204.25
3 page a min speed, 360 dpi, small footprint & 80 page sheetfeeder
BJ230wide carriage version of BJ200 only £274.03
- Canon BJ300 £348.93
Desktop bubble jet with near laser quality. BJ330 Wide carriage version of the BJ300 £395.74
- Canon BJC600 Colour £370.20
Colour bubble jet. Excellent quality
- Canon BJC4000 Colour £323.40
New colour bubble jet from Canon. Excellent quality

EPSON

- Epson LX300 Colour £127.65
9 Pin 80 Column colour
- LQ150 Colour £178.72
24 Pin Draft 24pins, LQ79pins
- Stylus 800 £212.76
48 Nozzle inkjet 360 x 360 dpi (max) 100 sheet feeder
- Stylus colour £382.97
Colour Inkjet, 360 x 360 dpi, 720 x 720 (on special paper)

CITIZEN

COMPUTER PRINTERS

Citizen printers have a 2 year guarantee

- ABC Colour printer £131.91
24Pin printing as easy as ABC, complete with 50 Sheet auto sheet feeder
- Swift 200 Colour £154.89
Same out put as the 240 but with less facilities
- NEW! Project II Colour £221.27
new inkjet printer with built in auto sheet feeder
- Printer Stands (Universal) only £4.25
- Turbo Driver for Canon / HP / Epson
Please Specify £39.00

HEWLETT PACKARD

- HP 320 Portable £199.99
- NEW! HP520 Mono £238.29
- HP 500 Colour £238.29
- NEW! HP 560 Colour £374.46
even faster than the HP550C//All HP printers come with a 3 year warranty

THE STAR

COMPUTER PRINTERS

- Star LC100 Colour £106.38
- Star LC90 Mono £93.61
- Star LC240 Mono £107.23
- Star LC240 Co £123.40
- Star SJ144 Colour Thermal £212.76
Stunning affordable colour printer. 3 PPM, low running costs

HARD DRIVES

A300/A400/A5000 3.5" Drives

IDE Card (A300/A400)	£69.00
260Mb 3.5"	£116.00
340Mb 3.5"	£124.00
420Mb 3.5"	£143.00
540Mb 3.5"	£168.00
A5000 Requires 2nd HD Kit	£17.00

2.5" Internal *Inc Interface

SIZE	A3020	*A3000	*A3010
60Mb	£110.63	£169.63	£169.63
80Mb	£119.14	£178.14	£178.14
120Mb	£136.16	£195.16	£195.16
170Mb	£208.50	£267.50	£267.50
250Mb	£212.12	£271.12	£271.12
520Mb	£357.44	£416.44	£416.44

A3000 or A3010 Internal IDE Card
(For 2.5"HD) Available separately £65.00

PRINTER CONSUMABLES

RIBBONS

Citizen Swift mono ribbon	£4.25
Citizen Swift Colour ribbon	£11.91
Star LC100 mono	£3.14
Star LC200 mono	£4.25
Star LC100 colour	£6.80
Star LC200 colour	£11.00
Star LC24-30 mono	£7.65
Star LC24-30/200 Colour	£10.20
Re-ink Spray for mono ribbons	£10.20

COVERS

Star LC10/20 cover	£4.25
Citizen Swift/ABC	£5.10
HP 500/550/510	£5.10
Star LC24-300/300/100/200	£5.10

PAPER (fanfold or single sheet)
prices apply only when ordered with printer
or purchased direct from the showroom

1000 sheets	£7.65
2000 sheets	£15.31

Delivery for 2000 sheets £4.26
when purchased without printer

Tabby Graphics Tablet

The Amazing new graphics tablet for the Acorn Range of computers. Software developed by First Computer Centre. Works with all major software. Rated 100% in Amiga Computing. **Only £68.08**

Special Bulk prices for Educational Establishments
Works on A3000 Series onwards
Requires RiscOs 3.1 or above.

SUPRA MODEMS

Supra come with comms s/w & cables

SupraFAX Modem 288

NEW Super fast! V34, 28,800 bps + 14,400 Fax
only £199.00

SupraFAX Modem 144LC

Features as below but class 1 fax only & without alpha numeric display. "Performs perfectly, never missing a connection"
...Computer Shopper April 94
now only £80.00

SupraFAX Modem V.32bis

14400 baud, V32bis/V32bis/V32bis/MNP2-SV 42/V42bis, Class 1 & 2 commands, 9600/14400 Group 3 Fax. Includes free comms (not fax) w & cable. "Excellent performance, this modem should be on everyone's shortlist"...Computer Shopper April 94
only £146.00 93%

US Robotics

WE ARE PREFERRED USR DEALERS

- Sportster 288 +FAX v34, 28800 BPS
now only £199.00
- Sportster 14400 FAX £124.00
- WorldPort 14400 +FAX £169.00
- Courier HST/Dual 16.8 Turbo Fax
only £289.00 (limited offer)

If you thought V32bis was fast try turbo! They come with a 5 year warranty & are BAST Approved
Acorn Modem Cable £8.50

3.5" DISKS

QTY	Bulk DD without labels	Bulk HD without labels
10	£3.82	£5.10
50	£17.86	£19.57
100	£32.33	£36.59
500	£143.82	£170.20

Labels available - 50 @ £0.85 100 @ £1.70 500 @ £5.95 1000 @ £8.50

QTY	Branded DD with labels	Branded HD with labels
10	£4.67	£6.80
50	£19.57	£25.52
100	£36.59	£45.10
500	£162.54	£170.20

MONITORS

- Acorn AKF52 14" Monitor £196.00
- IIDEK Vision Master 17" Monitor, 0.26 Dot pitch 1280 x 1024 at 80Hz refresh, MPR II £584.00

MEMORY

- RiscPC 2Mb £85.10
- RiscPC 4Mb £119.14
- RiscPC 8Mb £234.03
- RiscPC VRAM 2Mb £159.00
- With 1Mb Vram Traded in £119.00
- A3000 1Mb to 2Mb £49.00
- A3010 1Mb to 2Mb £43.50
- A3020/A4000 to 4Mb £85.50
- A5000 2Mb to 4Mb £85.50

CD-ROM DRIVES

- RiscPC - Internal
 - Cumana Indigo CAA300i (IDE) £194.00
 - CAA300ia(IDE) with Audio Mixer & Artisan 2 CD £242.00
 - 300i to 300ia Upgrade £60.00
 - Cumana Indigo CAA401 (SCSI) £194.00
 - Cumana Indigo CAA631 (SCSI, Caddy Load) £292.00
 - All Acorn Machines - External
 - Cumana Oscar (Parallel) £223.00
 - Cumana Bravo (Parallel or SLCD) £292.00
- Please specify machine when ordering
(Add £50.00 for ProArtisan 2 CD)

MISCELLANEOUS

- MIDI Max (Midi Interface) £68.00
- MIDI Cables (x2) £5.11
- Scanlight/Video (WildVision) £199.00
- RiscOS 3.1 Upgrade £74.04
- RiscOS 3.1 Upgrade Only - no Manuals £42.55
- Acorn Original Mouse £29.78

PREMIER Ink Refills

- save a fortune in running costs with your ink/bubble jet. Compatible with HP, Canon, Star, Citizen & many others.
- single refills (22ml) £5.95
 - Twin refills (44ml) £11.06
 - Three colour kit (66ml) £17.00
 - Full colour kit (88ml) £23.82
 - Bulk refills (125ml) £21.27
- Cartridges
- Canon BJ10 cartridge £16.16
 - Double life 500 cartridges £23.82
 - HP550/500 colour cartridge £23.82
 - Star SJ48 cartridge £16.16
 - Star SJ144 cartridge (pack of 3) £36.59
 - Star SJ144 mono or colour (3 pack) £14.46
- Miscellaneous
- Printer Switch Box 2 way £11.06
 - Printer Switch Box 3 way £17.00
 - 3 Metre printer cable £5.95
 - 5 Metre printer cable £7.65
 - 10 metre printer cable £11.06
 - Dust cover AKF10/A3010 Keyboard £45.10
 - Dust Cover AKF12/17/30/40 £11.91
 - 10 Capacity Disk Box £0.84
 - 50 Capacity Disk Box £3.40
 - 100 Capacity Disk Box £4.67

Letters

PC on the cards

If Acorn has accepted the inevitable fact that it will have to satisfy the demand for faster PC processors, I consider it short-sighted to release a hard-soldered PC card at this stage. If it had been able to do so when the Risc PC was first released (and the price of the PC card was announced) then that would be fair enough, but already the specification of the processor is looking sluggish. For example, today's national press is carrying an advert for comparatively cheap Pentium driven PCs.

As far as Aleph One is concerned, given the prices scheduled for its cards, it should wake up to the fact that it can't expect to recover all its R&D in the first few hundred sales. The suggested prices, when compared to full PC motherboards, are a complete nonsense, and will not in any way add to the saleability of Risc PCs. No wonder the schools in this area who have been loyal to Acorn since the advent of the Beeb are moving over to PCs – overall cost, including maintenance, is fast becoming the paramount factor. Other than *Impression Publisher* there is still no serious software for the Archimedes or Risc PC to interest the business user, and there just aren't enough of us Acorn enthusiasts to carry the flag indefinitely.

Multimedia is no doubt the future, but look at the quantity of CD-ROMs available for the PC compared to the Acorn platform. Out of interest I purchased the *British Birds* CD-ROM from Cumana via my Acorn dealer at a cost of £150 + VAT. It was advertised in the Cumana catalogue as Acorn compatible, but only when I bought it did I find it's not compatible with the Risc PC. My dealer managed to write some software to get it running partially, but the floppy disc that forms part of the package was corrupt and was returned to Cumana by my dealer six weeks ago – we have still not received a replacement in spite of

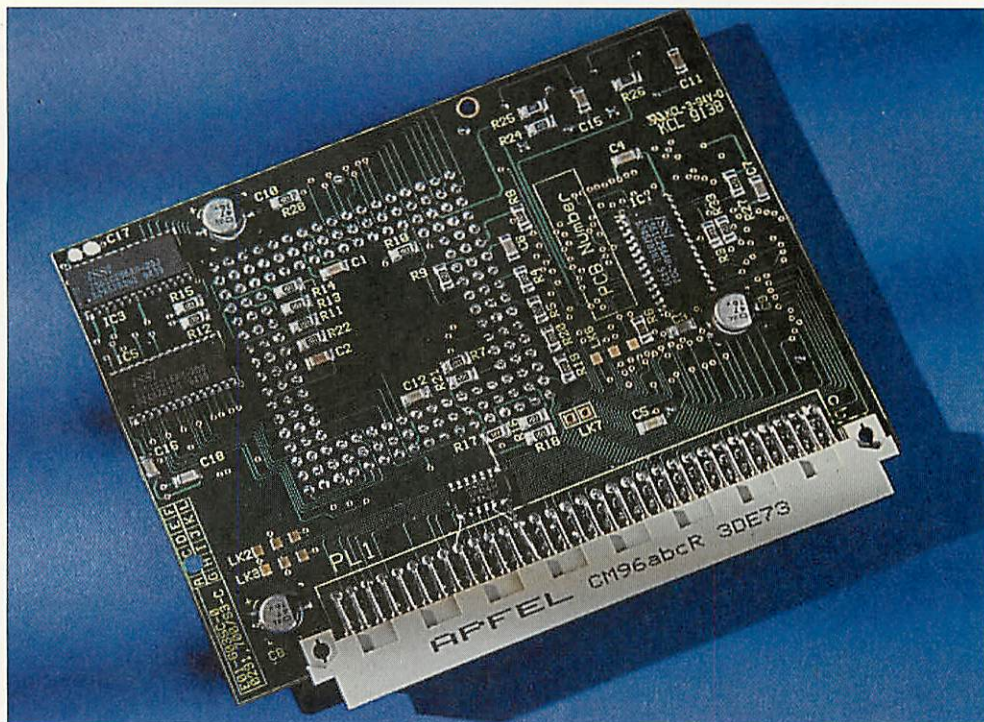

The Acorn PC Card: it isn't the fastest option, but then again, it's not supposed to be.

reminder faxes from me!

I still prefer my Risc PC and A540 to a PC, but I sometimes think I must be mad!

Roy Smith
Orpington

Harsh criticism, methinks, considering the Acorn PC card costs under £100. The whole point of Acorn's card is that it represents the most cost-effective PC upgrade route, and the Aleph One cards are for those who need that bit of extra power. Having used one for a while, the Acorn 486 card feels just as fast as a typical 486SX PC, and for £99 (including PC-DOS) that looks like incredible value to me.

I'll reserve judgement on the Aleph cards until I've seen them working, but it's wise to take Acorn's product at face (and monetary) value. It isn't supposed to be the fastest, but it is supposed to be the cheapest. (MM)

Missed macro

Steve Powell is mis-informed when he states that *PageMaker* does not have any macro capability ('Knowing your Ps and Qs', *Acorn User*, Christmas 1994).

PageMaker has a 'Run

Script' addition and, while there are no keyboard shortcuts to invoke a given script, anyone persistent enough can, in fact, produce a complete layout without once touching the mouse. There are commands like 'Import', 'Place' or 'Resize' that enable graphics and text to be imported, placed and resized.

I also disagree with the assertion that *Quark XPress* is the most popular DTP package in the world. It might be the software to beat in terms of features, but it is by no means the most popular. Remember, *PageMaker* is the first commercially successful DTP package – the term 'desktop publishing' is even reputed to have been coined with regard to *PageMaker*. The program itself has been available for years on both the Macintosh and the PC, the two most 'popular' in terms of numbers of users.

Carmello S J Juinio
Philippines

Don't confuse 'popular' with 'first': Arthur was the first operating system for the Arc, but I wouldn't call it the most popular. On a more serious note, I accept that *Quark XPress* isn't the most numerically superior package, but I would say

that its users are far more enamoured to the package than those of any other DTP system (bar *Impression*, of course): wouldn't that make it the most 'popular'?

At the end of the day, it's another of those personal preferences. A bit like preferring the Acorn operating system to System 7 or Windows... (MM)

CD gone

I have recently bought a CD-ROM drive for my A3010, and am very disappointed with the lack of information available on CD-ROMs. Could you please urgently publish a review of the most popular CD-ROMs currently available?

I also wonder if it would be feasible to produce a sort of Omnibus edition of *Acorn User* on CD, every three months or so, with the contents of the three months' discs, the news section, top quality clip art, the latest program demos, CD-ROM reviews and so on. Obviously it would be more expensive, but I, for one, would be willing to pay the extra cost – it could be distributed to customers directly through an annual subscription.

I notice that there are several CD magazines for both Mac



Write to Acorn User, Europress Publications, Europa House, Adlington Park, Macclesfield, SK10 4NP

and PC users, but there are none as yet for the Archimedes. We may not be able to beat them in terms of quantity, but I'd rather have quality any day. If *Acorn User* could periodically produce a top-quality Archimedes CD magazine, I'm sure it would be good news to all users in education, business and at home who have an Archimedes and a CD-ROM drive.

Thomas Smith
Edinburgh

See Viewpoint. (MM)

Totally lost

I've been receiving your magazine for a while now, but am understanding very little of it. I bought my Acorn A3010 as I was told it was 'idiot proof' and used in schools. It has worked fine and I bought the magazine, but I find you have to be a computer expert to understand the articles - then again, until I got the Acorn I thought that a mouse was a rodent!

Please include articles for total idiot-beginners like me. After all, I never saw a computer in school - how else can I learn? The manuals aren't very great either.

Sheila Munro
Moray

Fear not! We'll be bringing back our 'Absolute Beginners' series in the April issue, after an absence of just over a year. They'll take you from complete beginner to total expert, or your money back. Well, when I say 'money back' I don't really mean it, it's just a figure of speech... (MM)

TV junkie

I have also had some luck in spotting Acorn's computers on television. Two years ago the A3010 was featured on *Games Master*, albeit for ten seconds, in a comparative review with the Amiga 1200 and Atari Falcon, because they all contained brand new hardware. It's good to know that something which is five years old can still be regarded as brand new.

In Autumn 1993 there was

another A3010 feature on the ITV programme *Movies, Games and Videos*. They assured everyone that the Acorn isn't just a boring classroom computer, but actually has a lot going for it. To back this up, we were told that *Simon the Sorcerer* would be available by Christmas!

That computer programme *The Net* did mention the Arc. One notable feature was the creation of multimedia presentation using full-motion video. The presenter said the Risc PC would be a very good choice (one was even shown) but it did not stop him from using a PC. *The Net* also had a couple of other Acorn bits. I actually spotted an *Acorn User* cover disc, and there was an article about computers in education which, perhaps not surprisingly, showed Acorn A3000s.

In the last couple of months I have also seen Acorn computers on two other BBC programmes: *Panorama* and *Children in Need*. The *Panorama* clip was another school scene, while the one from *Children in Need* was a lot more exciting, not just for me, but for the children who benefited from the application the machine had been put to. The computer was shown connected to an X-ray machine, I think, and the Arc was used to look at the images created.

I think there should be a lot more coverage of the Archimedes on television: it seems ironic that the company who supported Acorn for about ten years, the BBC, now acts as if the machines no longer exist. Is the selling of *Acorn User* last year from the BBC a case in point?

Luke Sluman
Surrey

Not that I'm a sad computer spotter, but I can remember a couple more TV appearances for Acorn. The first was in *Capital City*, where A310s ran the office. Life in the fast lane, eh.

The other was in an advert where a bloke using an Arc couldn't understand why it didn't work. It turned out not to be plugged in: advert humour, it's the best. (MM)

Viewpoint

Look around in the PC and Mac worlds, which is something every self-respecting technophile should do from time to time, and you'll see that CD-ROM is the hippest, trendiest fad at the moment. There are CD-ROM magazines devoted to the medium; there are adverts covering pages and pages flogging CD-ROMs for ridiculously low prices; there are round-up reviews of CD-ROM drives every other month in the main magazines.

But why isn't this the case in the Acorn world? Acorn's marketing philosophy has been pushing the Acorn platform as a multimedia-capable system for ages, since the Domesday project on the BBC Master, in fact. Hailed as one of the first true multimedia projects, Acorn produced a 12in LaserDisc crammed with pictures and sound effects describing the country in the same way as the original Domesday book, and the software ran on a BBC Master. Great for its day, but it cost so much that it didn't really take off. It's a shame: nowadays, that sort of collection of information would go down a treat with the multimedia cognoscenti.

But these days the number of Acorn CD-ROMs is not that big compared to PCs and Macs, and those who do produce CD-ROMs are beginning to produce them in multiple formats, for the Acorn, PC and Mac worlds. There was a wonderful agreement decided back in the middle of 1993 called the MultiWorks Project, which was an EC-funded project to produce a standard for CD-ROMs that would work on PCs, Acorns and UNIX boxes without anyone having to worry about creating different CDs for each of the platforms. Have you seen any CDs produced under this agreement? Does Acorn market a MultiWorks system? Err... no, I don't think so.

Despite the comparatively small size of the Acorn CD-ROM market, it's obvious that a lot of people want a CD-ROM on the cover of *Acorn User*. But look at it from our point of view: in the present marketplace it would be fatal to our sales. Our last reader survey (done about a year ago) showed that just 8.5 per cent of our readers owned a CD-ROM drive, and 28.7 per cent were intending to buy one in the next year. So, if our readers were telling the truth (which, of course, they were) about 37 per cent of our readers should have CD-ROM drives at present.

Now that might sound like a lot, but we couldn't afford to put both the CD and the floppy on the cover - it would have to be one or the other - and considering 100 per cent of our readers have floppy discs, the choice is obvious. And we don't have a big enough circulation to provide both a CD and a floppy version at the same time, like *Mac Format* et al.

Besides, would you put up with us charging £4.95 for the CD version of the magazine, which is the standard price for a magazine plus CD in the Mac market? I doubt it: the reaction when the price went up to £2.95 in the October 1993 issue was bad enough, and that was justified by the addition of the cover disc, and the consequent filling of the Yellow Pages with more articles rather than listings.

Another interesting related point is that a number of readers - owners of new machines, obviously - wonder why we don't put high density discs on the cover, rather than the older 800K floppies. If you haven't guessed the answer, then I'm surprised: it's because there is a considerable portion of our reader base that owns older machines without 1.6Mb drives, and they couldn't read the discs.

However - and here comes the 'isn't *Acorn User* the best magazine in the world' plug - we are putting a CD-ROM on the cover of the April issue. This is in addition to the floppy disc, so don't get all irate if you don't own a CD-ROM drive. At the moment this is a one-off promotion, so don't get carried away that we'll be doing it every month. And no it's not an April fool: we are putting one on.

If everyone buys CD-ROM drives we'll think again about cover CDs, but until then it's 800K floppies, I'm afraid. And the thought of compiling a 650Mb CD-ROM every month puts the fear of God into our disc editor, so don't count your chickens even if that happens.

Mark Moxon

SILICON VISION®

DESKTOP SOLUTIONS FOR ACORN COMPUTERS

SolidCAD®

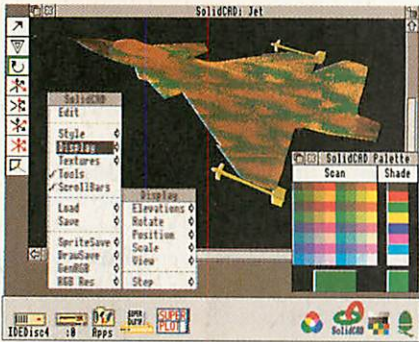

Comprehensive 3D CAD & Visualisation with the fastest rendering & animation. £79.95

SolidsRENDER®



Most advanced Ray-Tracing package that is 2 to 10 times faster than the competition. £79.95

SolidTOOLS®



Fully integrated environment for 3D Conceptual Design and High Quality Presentations. £195

ArcPCB™

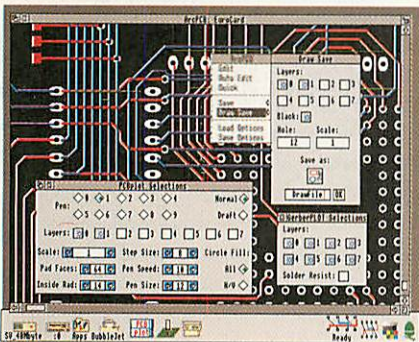

The most comprehensive Electronic Design Automation Tools starting at only: £99.95

LOGIX™

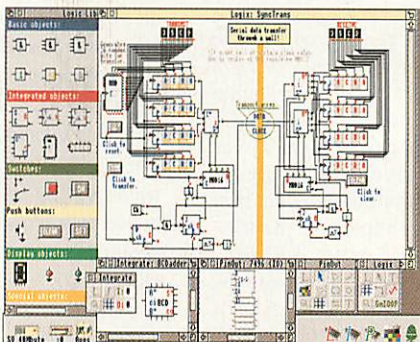

Digital Design and Simulation Tools with extensive customisable libraries. £99.95

AlphaTracks™

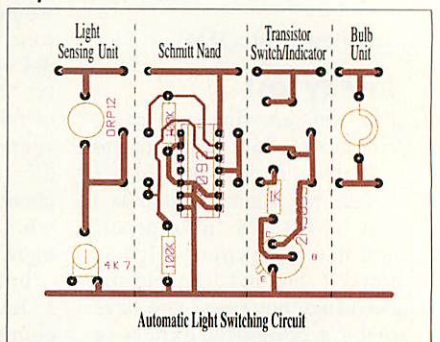

The complete Electronics Teaching Course for Schools based on ArcPCB. Site License: £75

WimpGEN™

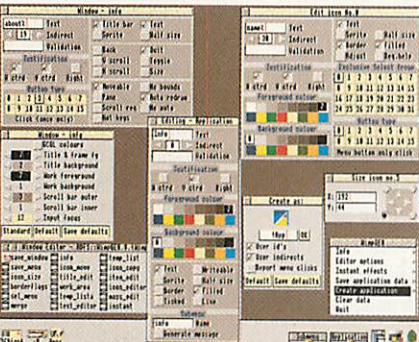

RISC OS User Interface Design and Generation tool for rapid applications development. £79.95

RiscBASIC™ Compiler

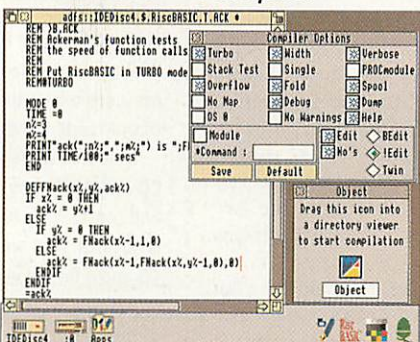

Unrivalled BASIC V & VI Compiler for creating secure high-speed applications. £79.95

RoboLOGO®

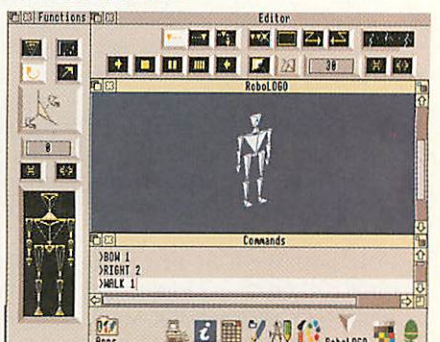

The ideal introduction to computing with 2D & 3D Turtlegraphics plus Robot control. £39.95

ProSHEET™

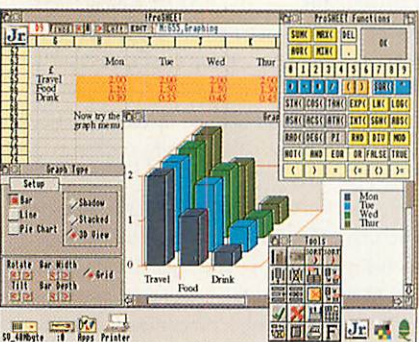

Combines ease of use with full featured functionality at an affordable price. £39.95

ShareHolder™

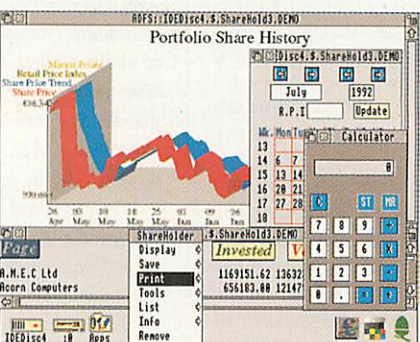

Comprehensive Share Portfolio Management for £79.95, or £125 with Teletext/Prestel links.

Payroll Manager™

Employee	Units	Rate	Value	Deductions	To Date
Hours: 1.88	875.00		875.00		Pay: 875.00
Hours: 1.88				PAYE: 131.75	Taxable: 577.50
Hours: 1.88				NatIns: 67.74	PAYE: 131.75
Bonus:					Misc: 5.00
S.S.P.:				Pens: 18.00	Pens: 18.00
Hol.Pay:				Misc: 5.00	Misc: 5.00
S.N.P.:					
Total:			875.00	214.49	NettPay: 660.51

Complete & easy to use Payroll Manager handling the latest budget changes. £79.95

Free Colour Brochure

For more details on our complete RISC OS software range please enquire for our free Desktop Solutions Colour Brochure.

All products are available now. Prices exclude Carriage @ £3 & VAT. Educational official orders accepted.

SILICON VISION LTD, SIGNAL HOUSE, LYON ROAD, HARROW, MIDDLESEX, HA1 2AG, UK. TEL: 081-422 3556, FAX: 081-248 3589.

Software Site Licenses are 3 times the RRP for use on up to 20 stations or individual machines. Enquire for specific cases. All product titles are registered trademarks or trademarks of Silicon Vision Ltd. All other trademarks acknowledged. Copyright © 1994 Silicon Vision Limited. All rights reserved. All RISC software support RISC OS 2 & 3 and the Risc PC.

Under scrutiny this month:

US Robotics 28,800 Fax modem

- WimpGEN • Font Designer's Toolkit
- MMViewer • Upgradeable 4Mb SIMMs
- for the Risc PC • Network Acorn book

In brief

4Mb upgradeable SIMMs

Supplier: Simtec Electronics

Tel: (01772) 812863

Price: £125 + VAT (4Mb),
£250 + VAT (8Mb),
£125 + VAT (4Mb-8Mb upgrade)

Pros: Allow you to upgrade memory in stages • No need to throw out old SIMMs

Cons: More expensive than 'ordinary' SIMMs

Hats off to Simtec; this is a very neat idea. Instead of producing 4Mb and 8Mb SIMMs as different modules, the 8Mb upgrade is simply the 4Mb upgrade with another eight RAM chips added. Furthermore, anyone with the 4Mb upgrade can turn it into an 8Mb upgrade simply by pushing the eight chips into waiting sockets. It's a user-fit upgrade, and removes the need to get rid of your old memory module when you upgrade.

For instance, say you have the 5 + 1Mb Risc PC model, and decide you want to run Windows on the PC card. You will need a further 4Mb of memory to do this, because Windows eats RAM voraciously. However, you only have one SIMM socket left in your machine for DRAM, so do you go for a 4Mb upgrade – which you might grow out of and have to discard or trade in – or

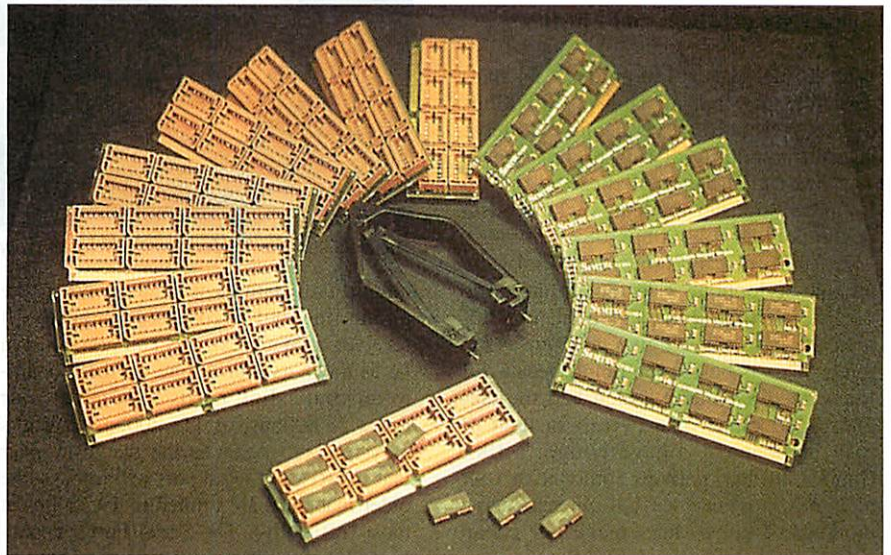

The revolutionary upgradeable memory for the Risc PC from Simtec. On one side, 4Mb of RAM soldered to the board; on the other, eight sockets waiting for 4Mb more.

an 8Mb upgrade – which might be a bit expensive at the moment? With the Simtec SIMM there isn't a problem. You can simply buy the 4Mb SIMM and upgrade it to an 8Mb SIMM in due course, with no financial penalty. Fitting the extra memory is a doddle, in fact it is faithful to the Risc PC's philosophy of easy upgrades.

The only drawback is that this is only at most an 8Mb SIMM. However, Simtec

hopes to have a 16Mb – expandable to 32Mb – SIMM available soon, and there is even talk of a SIMM which can be any of four, eight, 12 or 16Mb.

Incidentally, you should consider yourself lucky that you are not the proud owner of a Macintosh, which for some reason demands that the SIMMs must be upgraded in matching pairs, true hair-loss design.

David Matthewman

Network Acorn

Supplier: Northwest SEMERC

Tel: 0161-627 4469

Price: £12

Pros: Comprehensive network coverage • Disc very useful • Only book of its type • Low cost

Cons: Layout a little cluttered • Printing quality too dark

Network Acorn is a new book by Geoff Preston from SEMERC that aims to answer all those questions you might have about networking Acorn machines together, and for all those who have been through the tricky process of setting up a network from scratch, it's a welcome publication.

The book covers everything you would want to know when setting up and running a network, from the very beginning when

you must decide which type of network you require – 10Base2, 10Base5, 10BaseT or peer-to-peer, for example – right up to setting up the software and looking after the network. Interestingly Econet is omitted, and some purists might think that it should be mentioned as there are a number of Econet-based solutions still being used, but personally I think the omission is a good thing: no-one in their right mind should consider Econet these days.

One particularly good area of the book is the chapter entitled 'Software for the Network'. This covers all sorts of packages aimed at making the network a better environment, from application accelerators and font management to software to avoid. There is also a mention in this section of the alternatives to Acorn's Level 4 set-up, such as SJ Research's Nexus, and Oak Solutions' Disc Share; this is useful, but could have been expanded to cover hints and tips for these systems

specifically.

The disc which accompanies the book contains a number of useful utilities described in the book's Appendix, where the reader is also taken through the applications which make up Level 4 and Acorn Access.

In summary, this book is excellent. If you intend to set up a network, or already run one, then you'll find this book a useful summary of tricks and tips, and I have no doubt you'll learn something in the process.

I only had a couple of niggles: the printing quality was a little dark in my copy, making some of the screenshots very hard to read; and the person who laid the book out has yet to learn the value of repelling text round frames, as a large number of the pictures have text flowing very close to their edges. However these niggles are small, and at £12 this book is an essential purchase for Acorn network managers and users.

Philip Prescott

US Robotics Sportster 28,800 fax modem

Supplier: US Robotics Ltd
Tel: (01753) 811180
Fax: (01753) 811191
Price: £299 + VAT

Pros: V.34 (28,800bps) modem
• Works with *ARCterm7* and *Hearsay*
• 14,400bps fax with *ArcFax*

Cons: Ugly • No bells and whistles

With the decision at last on the V.34 standard for data transmission at 28,800bps (bits per second), several modems have become available at this higher speed. The most affordable of these is the US Robotics Sportster modem, slicker cousin of the popular 14,400bps USR Sportster. Like the older modem, it looks like a mutant Stylophone – in fact, if anything the green strip along the front clashes with the red LEDs to give an even worse effect. This is beside the point, because if I'd wanted a modem which had the elegance and grace of a Ferrari instead of just the speed, I'd have bought a USR Courier. In fact, perhaps someone at USR thought: 'How can we sell our expensive modems? I know, let's make our cheap ones look really tacky...'

The USR Sportster 28,800 supports V.34, V.FC (an older 28,800bps standard), V32bis (14,400bps) and slower data transfer rates. To use the highest speeds you will need either a Risc PC or one of the Serial Port's dual serial port interface cards. This is because the modem



The 28,800bps fax modem from USR looks tacky, but throws data around with no problem.

compresses data as it sends it down the phone line and uncompresses data as it receives it. With text, this compression can be as much as four to one, so the modem-to-computer-link needs to work at four times 28,800bps, or 115,200bps. Readers may remember this as the magic number that the Risc PC serial port will run at – the older machines are limited to 19,200bps at most (officially). The Serial Port's expansion card (£79 + VAT) provides an impressive 230,000bps on two serial ports, and is definitely worth considering.

Hearsay, *ArcFax* and *ARCterm 7* all drive the modem with no problem using the standard USR drivers. Transferring some sample files to and from the Arcade bulletin board confirmed the claimed

doubling in speed over the 14,400bps modem: text transferred at between 5200 and 5700cps (characters per second) and an archive at 2800cps (archives, being already compressed, compress less down a phone line). You do need a good line; connecting via the IDG switchboard I couldn't coax more than 14,400bps out of the modem while I connected at 28,800bps every time on a direct line.

Not everything has a 28,800 modem at the other end to connect to yet, but they will come in time, and then the extra cost of the modem will rapidly pay for itself in reduced phone bills (or else, you'll do twice as much web-browsing for the same cost).

David Matthewman

MMViewer

Supplier: Desktop Laminations
Tel/fax: 0117-979 9979
Price: £40 (£30 for CD-Circle members)

Pros: Allows Archimedes to read PC-format multimedia CD-ROMs
• Potentially huge resource base now available to Acorn users

Cons: User interface could be improved

CD-ROMs containing multimedia are common on the PC platform. Although the individual files can be read using CDFS on the Archimedes – and there are a number of PD utilities that will read .BMP bitmaps or .WAV sample files – putting everything together with the correct text will only work if you have a PC emulator.

Enter Ben Summers' *MMViewer*. This program does all the conversion and co-ordinates the result into a multimedia presentation; pictures, sound and text. At the moment it is unable to display AVI (video) files, but that facility is promised soon. It comes with a set of disc readers for various multimedia disc sets, which

are also sold by Desktop Laminations along with the viewer.

For instance, there is a four-disc set and a ten disc set called *MediaClips*. These contain images related to a particular subject – tropical rainforest, batik designs, business backgrounds and so on – and each image comes with a small piece of 'appropriate' music and a short descriptive text file.

I have to confess that this is my least favourite form of multimedia. It is little more than a slide show with incidental elevator music – in fact it can be run as such, making an attractive screen-saver – and the text with each image is far too short. I always wanted to know far more about the image than I was told.

To give just one example, on the Rainforest disc is a (very attractive) picture of a frog. This comes with some rather moody pan pipes music and the text 'Frog. Key Words: Frog, Amphibian. Colors: Brown, Green'. How much better this would have been with a sample of the frog croaking and some text giving at the very least the species, latin name, habitat, range and diet of the frog in question.

This is, of course, the fault of the discs

and not of *MMViewer* itself. The discs do make an excellent resource base for clip art, which I suspect was their main intended use. With better multimedia discs, *MMViewer* could really come into its own.

The main problem I have with *MMViewer* is the user interface. It should have been a lot better thought out, especially in a multimedia resource where the user interface is crucial. To give just one example, you can start a sample playing from a button on the tool bar, but in order to stop it you have to open a menu. There is a separate sound control box, admittedly, but why not have this on the rather empty tool bar? Furthermore, given that the CD-ROMs supplied by Desktop Laminations are clearly designed to be searched by keyword, why doesn't *MMViewer* do this?

Gripes aside, *MMViewer* is excellent value and opens a potentially huge resource base to Acorn owners with CD-ROM drives. Desktop Laminations/CD-Circle do a number of PC-format CD-ROMs at special prices with *MMViewer* – ask them for details.

David Matthewman

Font Designer's Toolkit

Supplier: iSV Products
Tel: (01344) 55769
Price: £30 inc VAT

Pros: Useful bundle of utilities • Should appeal to the font enthusiast

Cons: Not for novices • Most individual programs available cheaper elsewhere

RISC OS 2 outline fonts were – in their day – revolutionary. The font information was held as an outline rather than a bitmap, meaning that the font could be scaled to any point size easily. RISC OS 3 was added to this kerning information, allowing the spacing between, say, an 'A' and a 'W' to be altered individually, a typographical nicety which improves the look of the printed page no end. So-called WYSIWYG DTP systems like the Mac had (and still have) a lot of catching up to do.

Early on, Acorn released an application called *FontEd* for editing outline fonts, including the 'scaffold line' data which is used when rendering the font on screen and to most printers. While designing a font from scratch using *FontEd* would be fiddly and awkward, it does allow you to tinker with existing fonts, and has the secondary purpose of creating

bitmap files of certain weights of font, which greatly speeds up redrawing. *FontEd* is supplied as part of the *Font Designer's Toolkit*, along with a number of other tools from the iSV Products stable.

FontKern is probably the most useful of these, allowing you to edit the kerning information of a font. What makes it very useful indeed is that you can apply kerning information to a font which has none, either because it is a RISC OS 2 font or because the font designer didn't include any. *FontKern* comes with a number of possible kerning data files, but if none of them are suitable it is possible to extract kerning data from an existing kerned font. Once you have applied the data to the font, you can 'tweak' it to match the needs of the font exactly. This is something that will probably only be done well by experienced professionals, but that has never stopped keen amateurs meddling for fun before.

FontTrix will create new weights and styles of a font. Users of *EasyFont* can do this already – with better control in some areas – but others will welcome the ability to create Trinity.Inebriated at a 40 degree rotation. Probably.

FontCatalogue will print a listing of your fonts and display a *Chars*-style window showing a particular font. You can print out a listing of

your fonts, though this takes up a lot of memory if you have a large listing, and won't print to PostScript printers because of the number of fonts that would need to be downloaded to the printer.

Finally, *iSVMetric* displays information on the IntMetric – spacing and size – information for the font. Meddle with this at your peril, as it is very easy to produce fonts that look completely wrong. It is a very useful program if – like me – you are prone to using David Pilling's *D2Font* application to create fonts from your handwriting, only to discover that the bounding box for the font has got scrambled somewhere and it doesn't display correctly.

A word of caution if you use *FontDir* from LOOKSystems; you will have to copy fonts out of the partition to edit them, as *FontDir* write-protects the partition.

This disc is one for font enthusiasts, even those who just like to fiddle with existing information rather than creating their own from scratch. Most of the programs have counterparts from other companies – or in the PD scene – which are available more cheaply, although the full bundle isn't available elsewhere. Font designers will probably want something more, and iSV's next product may well satisfy them.

David Matthewman

WimpGEN

Supplier: Silicon Vision Ltd
Tel: 0181-422 3556
Price: £79.95 + VAT

Pros: Creates WIMP shell for a BASIC program • Code extensively commented • Full editing of windows and menus

Cons: Template editor could be better • Only outputs BASIC • Expensive

The problem with programming the WIMP is that it's a fiddly job, and requires you to write a large amount of basically standard code to handle windows, menus, file transfer and so on before you even start writing the application proper. To counter this, a number of people have written BASIC and ARM code libraries to do the hard work for you. These are mostly PD and are very welcome – the C version *DeskLib* is a vast improvement on Acorn's attempt. *WimpGEN* takes this one step further, allowing you to design templates and menus which it then drives using individually-tailored BASIC code.

To take an example, suppose you were writing a database. Your first step would be to use *WimpGEN* to design the windows and menus your program will use, at least as a first

attempt. *WimpGEN* would save a working application, with a BASIC file *WimpCode* which contains everything needed to install the application on the icon bar and handle all the WIMP events – opening and closing windows, creating menus and so on.

You can then get on with the important task of writing the database – routines to sort fields, fast search algorithms – without having to worry about all the WIMP code. With minimal care you can keep your code separate from *WimpGEN*'s, which means you can update the design of the user interface without changing your own code.

The thing that makes this most useful is that the BASIC code *WimpGEN* produces is heavily commented with page references both to the *WimpGEN* manual and the PRMs. This makes it all the easier to interface your own routines to *WimpGEN*s – you get a much better idea of what is going on.

The fact that *WimpGEN* produces BASIC is not really a problem, though it would have been nice to see it writing C as well. BASIC is easily fast enough to drive the WIMP operations of your program, and you can always code the speed-dependent parts in ARM code, or compile the whole thing with Silicon Vision's *RiscBASIC*.

As a tool for taking the pain out of

WIMP programming, *WimpGEN* succeeds admirably. There are better template editors out there – *TemplEd* and the beta-test version of *Glazier* which are both Freeware – but *WimpGEN* offers much, much more. Despite the fact that experienced WIMP programmers probably won't need it – and its price tag might deter others – it is a useful product that anyone getting into WIMP programming should consider buying.

David Matthewman

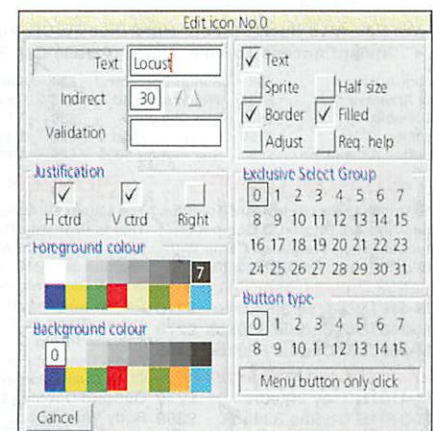

The dialogue box for icon editing. The options are extensive, but an 'OK' button would improve usability, especially as 'Cancel' doesn't actually cancel changes made while the dialogue box is open.

Chess II

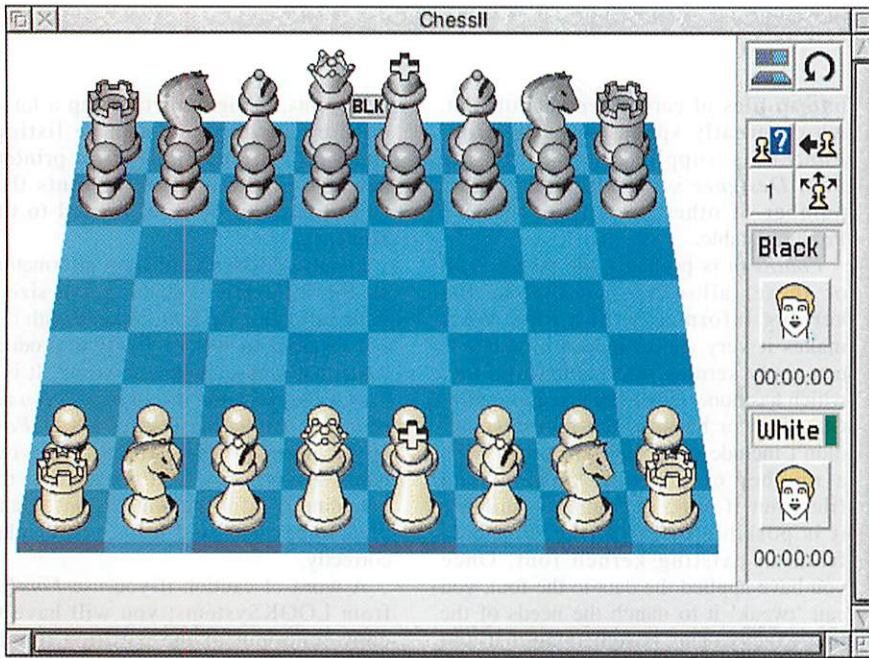

A brilliant new version of the Chess program Acorn User acclaimed as the best. All the features of the old program, plus Choice of 2D or 3D board, Save game as Sprite, Draw or Text, Rotate board, Show hint. Easy setting of play level. Replay last move. Show possible moves. Continuously updated history window. Improved game play. RISC OS Printer driver support. **Upgrade from Chess 1 to Chess 2 £10+old disc. Prices all inc.**

£16

Bubble Help 2

Bubble Help is a replacement for RISC OS !Help. It provides help where you need it - at the pointer in a cute bubble.

It makes full use of outline fonts so help is easy to read. Bullets and justifies text. Doesn't use much memory.

RISC PC and Network compatible. Fully configurable. Comes with printed manual and a choice of bubbles

Price £5 all inclusive.

David Pilling, P.O. Box 22, Thornton Cleveleys, Blackpool. FY5 1LR.

Free Air Mail delivery on overseas orders. Extensive range of other software available (ArcFax, ImageMaster, SparkFS) please send for catalogue.

Armtech

AUTHORISED ACORN DEALER
SALES & REPAIRS

PD CD 650meg Of Public Domain Software On CD (Available Now DPD_CD1)

Soon CD2/3 With 650meg On Each Disc.
DPD_CD2 Contains Symphony Tunes And Samples
DPD_CD3 Contains 24bit Scanned Colour Images In Tiff & Sprite File Format. **£35 each + vat**

Scanning Service Available And Supplied In Various File Formats (Please Call For Details & Prices)

Also Available CD Mastering At £85 A Disc

We Can Also Back Up Your Hard Disc To CD-Rom Giving You Instant Access To Your Data. (Please Call For Details)

Acorn Advance	£98	Simon Sorcerer	£34	Flashback	£24
CC. Artworks	£135	Wolfenstein 3D	£25	Spobbleoid	£21
CC. Publisher	£135	Sim City 2000	£34	F.T.T	£21
Desktop 'C' V4	£159	Cannon Fodder	£22	E-Type 2	£29
Desktop Assembler	£99	Star Fighter 3000	£25	Arcturus	£21

CD-ROM DRIVES

The Drives Listed Below Are Toshiba Units And Are Photo CD Compatible (Multi session) They Also Come With Driver Software For CDFS 2.20.

Internal Drives (RiscPC Only)	
XM-4101B/2 Tray 300kbs	£210
XM-3401B/2 Caddie 330kbs	£279
XM-3501B/4 Caddie 600kbs	£395

External Drives (All Machines)

XM-4101B Tray 300kbs	£279
XM-3401B Caddie 330kbs	£389
XM-3501B Caddie 600kbs	£475

None of the above include Interface.

SCSI INTERFACE CARDS

Morley Uncached	£169
Morley Cached	£189
Cumana SCSI 11	£200
HCCS 16bit Scsi Card	£99

PIONEER DR-U104X

The Latest Offering From Pioneer, This Is Probably The Only Drive To Have Any Impact At All On The Toshiba 3501B/4. Quadruple Speed With A Data Transfer Rate Of 614kbs Caddie Loading, High Speed Access 190ms (Random Access) Kodak Multi Session Photo CD Compatible Stereo Audio Outputs For Playback Of Music CD's. Dust Countermeasures By Outward Opening Front Door And Body Vinyl Cover.
Internal Unit (RiscPC Only) **£385**
External Unit (All Machines) **£479**

CD CADDIES

None of the above include Interface.	
SCSI	
Internal Unit (RiscPC Only)	£385
External Unit (All Machines)	£479

Monitors

IDEV VISION 15" FST Monitor	£319
IDEV VISION 17" FST Monitor	£589
IDEV VISION 21" FST Monitor	£1499

PLEASE ADD VAT TO ALL PRICES
PLEASE CALL FOR SOFTWARE PRICES

RiscPC's Include 12 Months On Site Warranty

RiscPC 2MHD210	£1249
2meg Dram AKF60 Monitor 210 HD	
RiscPC 5MHD210	£1399
4/1meg Dram/Vram AKF60 Mon. 210 HD	
RiscPC 9MHD420	£1699
8mb/1mb Dram/Vram AKF60 Mon. 420 HD	
Above With AKF85 17inch MultiScan	Add £400
ACM01 (SLICE) Case Upgrade	£99
ACA20 1mb VRAM Upgrade (Acorn)	£129
ACA21 2mb VRAM Upgrade (Acorn)	£199

Risc-OS 3 Upgrades

4mb simm RAM	£135	8mb simm RAM	£260
16mb simm RAM	£450	32mb simm RAM	£600
RiscPC 486 PC Card			
MS/Dos & Windows 3.11			
Ethernet Interface Card			
Acorn Access (RiscPC)			

HARDWARE UPGRADES

ARM 3 Upgrade with FPA socket	£139
T/Driver CANON / DESKJET/EPSON	£45
Dongle Dangle	£7
ArmStick JoyStick Interface	£28
Keyboard Extension cable	£19.95
Midi Expansion Card	£69
Replacement Mouse	£25
Micro Mouse (Clare's)	£11
QuickShot 2 Turbo Joystick	£76
Risc-OS 3 Upgrade	£21
Risc-OS 3 Carrier Board 300/400	£20
Serial Upgrade A3000	£32
VIDC Enhancer (State Machine)	

BOOKS

Archi Assembly Language	£14.95
Risc OS 3 First Steps	£14.95
Archi Operating System	£14.95
ArtWorks Made Easy	£19.95
BBC Basic Guide (NEW 3.10/11)	£16.95
Basic Wimp Prog+Disc	£14.95
DabHand Guide To Impression	£15.95
Draw Help	£14.95
Game Makers Manual	£14.95
Graphics On The Arm	£99
RISC-OS 3 PRM's	£12.95
Wimp Programming For All	

86 Meadowbank, Moor Lane, Holway
Holywell, Clwyd. CH8 7EF
Tel/Fax :- 0352 715840

OPENING HOURS MON-SAT 10am-6pm

Acorn



Studio Graphics

TOP QUALITY CLIP-ART (DRAWFILES) IDEAL FOR SCHOOLS WE CURRENTLY HAVE 10 SETS AVAILABLE

SG001 Egypt 100+Files Mostly Colour	£8.00
SG002 Flags 270+Files (2 Discs) Colour	£15.00
SG003 General 100+Files Mostly Colour	£8.00
SG004 Xmas (1) 100+Files Colour / B/White	£8.00
SG005 General 100+Files Mostly Colour	£8.00
SG006 Borders/Caroons Colour / B/White	£8.00
SG007 Borders For Poster B/White	£10.00
SG008 Borders For Draw B/White	£8.00
SG009 Greek Clip-Art Mostly Colour	£10.00
SG010 Xmas (2) 2 Discs Mostly Colour	£12.00

MY WORLD UTILITY DISCS K/S (1/2)

Disc MW001 ANCIENT EGYPT	£12.95
Disc MW002 CHRISTMAS	£9.99
Disc MW003 ANCIENT GREECE	£14.95

SCHOOL ORDERS WELCOME C/W/ORDER

PRINTERS

CANON BJ200 / Turbo	£229/£279
Canon BJC600 Colour With Turbo	£399
EPSON STYLUS 800 COLOUR	£395
Refills for BJ10/DJ(Twin) BW/Col	£12/£13
Ink Cartridge for BJ10	£18
Black Cartridge For Stylus Colour	£26
Colour Cartridge For Stylus Colour	£36

Drives

540meg DEC	£199	£269
1 gig W/DIGIT	£499	£499
2 gig DEC	£.....	£965

CD-ROM SOFTWARE

ArtWorks (CC)	£169
ArtWorks ClipArt CD (CC)	£20
Frontier 2000 + 7 colour guides	£115
Hutchinson Electronic Encyclopedia	£79
Image Warehouse (Media Design)	£59
Illustrated Holy Bible	£25
Illustrated Works Of Shakespeare	£25
Gnannies Garden	£34
ProArtisan 2	£139
CD Lens Cleaner	£6

From Chester follow old A55 past Holywell until you see Moor Lane on your right, turn down Moor Lane, we are at the bottom on the right hand side (Big White Farm Gate) From Rhyll (As Above) but turn left into MoorLane before Holywell.

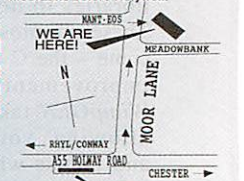

EEC add 17.5%vat to all prices except books. Prices and specifications subject to change without notification. Carriage is free (Except for books/Software/Risc-OS 3.11 & PRM's) these will be shipped at cost. Goods offered subject to being unsold and/or available. Goods not offered on trial basis. Next day delivery please add £12 + vat. Otherwise All goods shipped within 48 hours subject to availability. Restocking fee on non-defective returns.

Soundtrackers

Alex Clarke explores one of the most popular methods of composing music on your Acorn: Soundtrackers.

for the uninitiated

FEATURE

The majority of Archimedes owners will have come across Soundtrackers in one form or another. They can be found in demos and provide the musical accompaniment for most commercial arcade games.

The task of writing your own Soundtrackers can seem difficult because of the mathematical method in which they are edited and the use of hexadecimal effects codes. But this, in fact, makes soundtrackers extremely flexible and the effects commands are very versatile.

What are Soundtrackers?

Soundtrackers are pieces of music which are built up of samples. They usually have four, or sometimes eight tracks, and numerous effects, such as vibrato, portamento and volume slide can be applied to the notes. The format described here is the original Soundtracker format. Some editors, such as *Tracker*, use different codes

for their effects. Most of the advice will, however, still apply.

When you sample a sound, its waveform is stored by the computer and can be replayed fairly accurately. This allows you to use unusual, non-instrument sounds in your trackers such as the distinctive voices found in many dance tunes, like the famous 'Oh Yeah' and 'K-A-O-S' samples.

You can sample sounds using hardware and a sample editor but if you don't have access to a sampler, there are many samples available from Public Domain libraries and from within other Soundtracker files.

When deciding which samples to use, it helps to bear in mind the peculiarities of real instruments. For example, when a piano string vibrates it produces sound in other strings, called harmonics. When you sample a single note, the harmonics are sampled with it. A chord made up of

samples of single notes will sound artificial as the harmonics produced by a chord on a real piano are different. This is overcome by sampling not only single notes but also chords and intervals of two notes.

A chord can be played at a different pitch to produce another similar chord, i.e. a sample of C minor can be used to produce any other minor chord. The same applies to intervals. Not only will this sound better but will reduce the number of tracks used. Also, the same instrument is sometimes capable of making a number of different sounds. An electric guitar can produce muted and pinched sounds as well as strummed, and a slapped bass guitar string sounds very different to one played in the normal way.

The rhythm track

Once you have collected some samples and come up with a basic idea for a tune, the first thing to do is to lay down the rhythm, or the basic drum and bass tracks in other words. This will provide an idea of timing for the melody and backing tracks. Embellishments such as special effects, drum fill-ins and so on are best left until last.

Creating a drum track is one of the most difficult parts of writing a Soundtracker. The basic drum track gives the rhythm for other tracks but eventually you will want to improve it. Getting the timing right is vital as this will affect all other tracks. Decide what time signature you wish to use. Virtually every tracker is written in 4/4 time; in this case use a 64 event pattern. This would give you four bars with 16 events per bar. Each event is then a semi-quaver or 1/4 beat note.

If you wish to use shorter notes, each pattern could contain two bars with 32 events per bar played at half the speed to preserve the tempo. The set speed command, F, is the number of 50ths of a second between one event and another. F06 means 6/50 of a second per event. If there are sixteen events per bar then one beat is 24/50 of a second. From this you can see that the tempo is dependant not

Soundtracker codes

Code	Effect	Description	Example
000	No Effect	For arpeggio, a and b give the number of	C-2 1000
0ab	Arpeggio	semitones to shift note up in arpeggio.	C-2 1037
1aa	Pitch Slide Up	Continuously increase pitch at speed aa	D-2 4102
2aa	Pitch Slide Down	Continuously decrease pitch at speed aa	G#1 140A
3aa	Portamento	Slide pitch to specified note at speed aa 300 uses last value from current track	C-2 53FF --- 0300
4ab	Vibrato	Oscillate pitch at speed a and amplitude b 0's in fields use last value(s) from track	A#2 1482 --- 0400
5xx	Vol. Slide/Portamento	Vol. Slide (A) with 300 command combined	--- 05A0
6xx	Vol. Slide/Vibrato	Vol. Slide (A) with 400 command combined	D-2 060A
7ab	Tremolo	As vibrato, but volume oscillation Volume cannot go above C40	C-1 2774 --- 0705
8	Unused		
9aa	Set Sample Offset	Play from position aa within the sample	--- 091B
Aa0	Volume Slide Up	Continuously change volume at speed a	--- 0A10
A0a	Volume Slide Down	(minimum C00, maximum C40)	C#1 0A0F
Baa	Position Jump	Jump music to sequencer position aa	C-3 3B00
Caa	Set Volume	Set sample volume to between 00 and 40	--- 0C3F
D	Pattern Break	End pattern (only 1 per line required)	--- 0D00
E	Various	See manual for descriptions	
Faa	Set Speed	Set aa/50 seconds between events	C#2 4F00

only on the speed but also the number of events per beat. If you used one 64 event pattern per beat then the tempo would be slow, even if played at speed F01.

Now you can lay down your basic drum track. First enter the bass and snare, then add other drums and finally hi-hats – closed and open. Try to avoid cutting off a snare with a short or quiet sample as you will lose the sustain of the drum. Put cymbals on a separate track to allow them to ring over the usual rhythm. Use dotted quavers and semi-quavers or 3/4 and 1/4 beat notes in preference to quavers or half beat notes, especially in sequences of snares.

You can also try using unusual percussion sounds like rim-shots, bongos and bells and introducing instruments not normally used in the style of music you are writing. To make your drum tracks sound more human, accent the note on the beat by slightly increasing the volume of that sample.

The most distinctive features of Soundtrackers are the special effects. These can make the difference between an uninspired tracker and a really good one.

Special effects

The portamento effect is code 3 followed by a speed. It will perform the appropriate pitch slide up or down until the pitch reaches that of the last note specified with a 3 command. You may need several 3 commands to reach the desired note. You can also cause the slide to reverse by specifying a new note. Slide effects can also be improved by varying the speed on each event in the effect. You can create an effect similar to hammering on or pulling off a guitar fret with a

portamento of the fastest speed, FF.

Code A is the volume slide effect. This can be used to produce sustain and attack on samples. Sustain is achieved by a volume slide down to zero. This is especially effective on looped samples. To create attack on a note, set the volume to zero and use a fast volume slide up. You can get some interesting results by using opposing volume slides on two separate tracks. Play a sample from full volume to zero on one track while sliding up from zero to full volume on the other. If you use tracks that play through opposing speakers, and the same sound on each track, the instrument will move from one speaker to the other, giving a stereo pan. This technique can also be used to blend a note at one pitch into a note at another, or even to blend one instrument into another by using a different sample on each track. You can use this to create effects like the piano/strings voice on many keyboards.

Vibrato, command 4, is the variation of pitch around a central note and is commonly used on long notes where something is required to add a little interest to an otherwise boring section. It is often used with portamento to great effect on a bass line.

Command 7, the tremolo effect, is similar to vibrato but is a variation in volume rather than in pitch. It can sound out of place if applied to an instrument that in reality could not achieve this effect, such as pianos and guitars. It sounds excellent, however, on brass and wind samples.

The set speed command, F, is often just found in the first line of a pattern but can be used in other ways. This command sets the number of 50ths of a second which pass between each event. As we saw

Soundtracker glossary

Pattern	64 lines, 4 or 8 tracks
Line	One row of pattern, 4 or 8 notes
Note	Pitch + sample number + effect data
Pitch	Note and octave to play sample at
Sample number	One number/letter label for sample
Effect Data	Hexadecimal code for sound effects
Event	One 'row' of music being played
Speed	Time between successive events
Track	One 'column' of music
Sequence	Order to play patterns
Looped Sample	Never-ending sample; has loop
Sample Offset	How much of sample has played
Repeat Offset	Where looped sample section starts
Repeat Length	Length of looped sample section

earlier, when you decide on the timing you use each event as a certain note length. It is possible to use shorter notes. Say, for example, the speed of your tracker is 7. You can set the speed on each event, alternating between speeds 3 and 4. This will mean that 7/50 second will pass over two events rather than one so the tracker will be playing at double speed 7. If you then double the number of events in each note, it will maintain the tempo and you can use single events for half notes.

You can use triplet notes by tripling the number of events and alternating between three speeds which add up to the usual speed. The small difference between speed 3 and speed 4 will have no discernible effect on the timing. You get a syncopated effect by using two speeds which add up to double the usual speed for your tracker, e.g. with speed 7 you could use speeds A (10 in decimal) and 4.

Armed with this advice, it should be possible for you to write professional sounding Soundtrackers without too much trouble, so get composing. **AU**

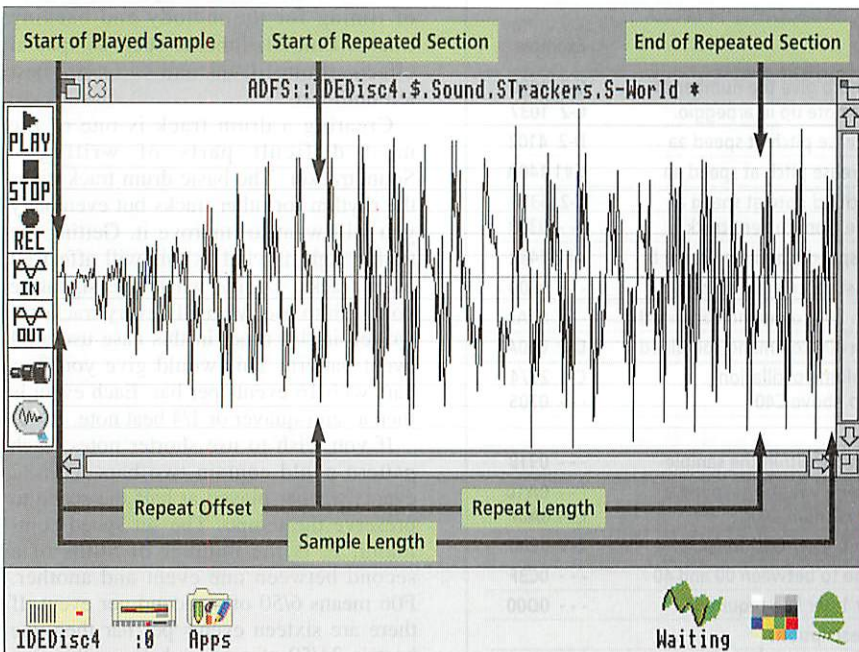

A sample loaded into Armadeus, a sound sample editor.

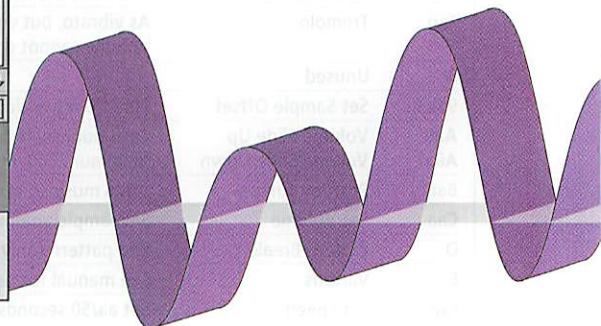

Complete CD ROM Systems

from £192 + VAT ~~£125~~

SCSI CD Rom Drives from ~~£150~~ + VAT

CD ROM Systems with SCSI Interface from ~~£269~~ + VAT
~~£225~~

Above prices are for RiscPC versions

CD Rom systems for A3/4/5000 available from £215 + VAT

Over 26 CD Rom systems available

Phone for our extensive CD ROM Price list

Ram for the Acorn RiscPC

4MB £110 + VAT = £ 129.25

8MB £212 + VAT = £ 249.10

16MB £391 + VAT = £ 459.42

32MB £750 + VAT = £ 881.25

Guaranteed Acorn compatible

0%* Finance On the

Acorn RiscPC

0% With up to 12 months to pay (dependant on deposit).

Also subsidised finance with up to 36 months to pay.

Please phone for further information.

*Finance is subject to status. Written details available on request.

CEmicro's

PHOTODESK

Total Graphics Environment

*Colour
Scanning*

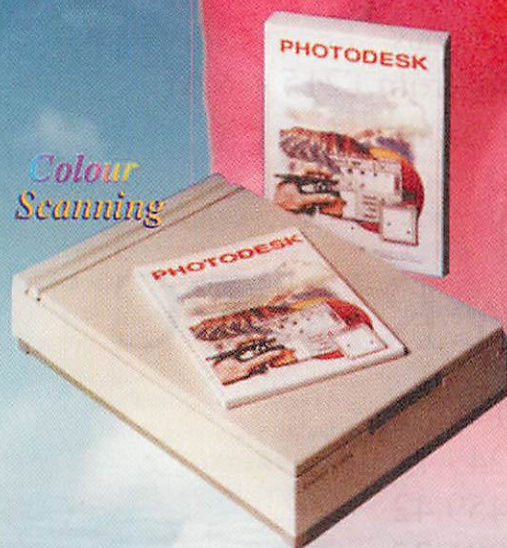

Photo Retouching



Original Artwork Production

Comprehensive Photo CD Support



*Colour
Printing*



spacetechn
space science resources

21 West Wools
Portland Dorset DT5 2EA
Tel 01305 822753
Fax 01305 860483

Graphics tablets are a boon to the computer artist. It is possible to draw with the mouse – it's *possible* to embroider in gardening gloves – but it's a clumsy and unnatural way of doing it. There is a wide range of tablets available at the £400 plus mark, at sizes from A5 upwards, which are probably essential for serious CAD work. However, computer artists may not need to make such a large investment.

The Wacom ArtPad and the Tabby graphics tablet both have a roughly A6-sized drawing area, and are 'budget' tablets. They are otherwise not directly comparable, being aimed at different ends of the market; however, it was convenient to review them both together.

The Tabby graphics tablet is the cheaper of the two, and comes with a rather bulky stylus. Select mouse clicks are emulated by pressing the stylus against the tablet – the tip of the stylus bends when you do this, slightly reducing accuracy. Select, Menu and Adjust clicks can also be emulated on the keyboard by Delete, Copy and Page Down, although if you do this the keys are no longer available for their normal function. Because the Tabby takes its power from the serial port, it won't work with pre-A3000 machines, and the software requires RISC OS 3.1 or later.

The resolution of the tablet can charitably be described as medium, since the cursor is noticeably jerky on an 800 by 600 screen. I didn't find this a problem, as drawing with the Tabby was in practice quite smooth. The tablet can be toggled on and off from the keyboard easily, and I soon got used to switching it off when I wanted to use Delete. However, an option to change which keys are used would be nice – how about Insert, Home and Page Up which I *very* rarely need?

The Wacom ArtPad is an excellent

Taking the tablets

Budding artists have been well-served by the arrival of two inexpensive and small graphics tablets, as David Matthewman finds out.

graphics tablet. It has a good resolution – I could pick up individual pixels in a 1024 by 768 mode – and 256 levels of pressure-sensitivity in the stylus tip. The stylus feels very natural and pen-like to use. As someone who owns an A5 Wacom tablet, I was pleasantly surprised by the ArtPad; the smaller drawing area wasn't restrictive at all and because the tablet was so light, I could easily hold it in my left hand and draw on it with my right.

The stylus has an extra button on the barrel which, by default, serves as Menu. Eesox and CC have different drivers to interface the tablet to the Archimedes. Both are configurable – you can use pen barrel, pen tip and a variety of keys as any of Select, Adjust or Menu – and are similar in many ways. The CC driver is slightly smoother and more responsive, and a lot easier to write your own software for. It also has a neat mode where

each movement of the pointer is made relative to the pointer's last position. The Eesox software will allow you to make both Select and Adjust pressure sensitive – CC's has an awkward half-way compromise on this – which is important for use with both *Photodesk* and *DA's Picture*. *Studio24* also uses the pressure-sensitive information, and a pressure-sensitive tool for *ArtWorks* is available from Eesox

Conclusion

The Tabby is an excellent entry-level graphics tablet, and budding Pic of the Month winners looking for something a bit easier to use than the mouse need look no further. Serious artists might need the pressure sensitivity and greater accuracy of the ArtPad, but they will have to pay for it. Unless you are fond of expansive sweeps of the brush or want to accurately digitise a diagram, the larger Wacom tablets are probably overkill, though if you have the money by all means spend it.

The ArtPad is bundled by a number of companies with art packages such as *Studio24* and *Photodesk*, so it is worth enquiring about this when you order one. **AU**

Product details

Product: The Wacom ArtPad
Supplier: Eesox/Vaughan Allanson
Tel: (01638) 578597
Price: £159 + VAT

Supplier: Computer Concepts
Tel: (01442) 63933
Fax: (01442) 231632
E-mail: info@cconcepts.co.uk
Price: £169 + VAT

Pros: Pressure sensitive • High accuracy • Very natural to use
Cons: Expensive (but good value)

Product: Tabby graphics tablet
Supplier: First Computer Centre
Tel: 0113-231 9444
Fax: 0113-231 9191
Price: £68.08 + VAT

Pros: Cheap • Simple to use • Does the job
Cons: Not pressure-sensitive • Medium resolution • Only one stylus button

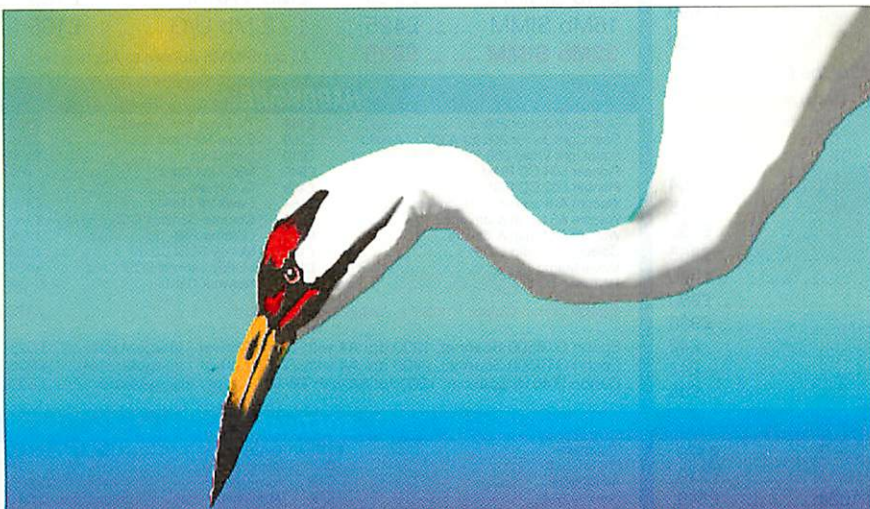

Although the Tabby tablet has a lower resolution than the ArtPad, and no pressure sensitivity, it is still far easier to draw with than the mouse. This picture of a Whooping Crane was drawn using the Tabby and *Studio24*.

Communications

USR Sportster FaxModem bundle	£215
14,400 modem, ARCterm, ARCfax 1.10 & cable.	
MultiTech ZDX FaxModem bundle	£235
19,200 modem, ARCterm, ARCfax 1.10 & cable.	
USR Dual Standard (V.Fast/V.34) bundle	£475
28,800 modem, ARCterm, ARCfax 1.10, cable & high performance dual serial card.	
High performance dual serial card	£79
Up to 230Kbps on two FIFO'd ports. If bought with a modem bundle, £69.	
ARCterm 7 (with free modem cable)	£68
Our highly acclaimed comms package.	
ARCbbs	£85

SCSI Storage Systems

Fujitsu 264Mb, 2yr gtee	£209
Fujitsu 353Mb, 2yr gtee	£235
Fujitsu 532Mb, 2yr gtee New 1" high model	£325
Fujitsu 1092Mb, 5yr gtee	£549
Fujitsu 230Mb MagOpt (with disk & sw)	£649

All drives include A3/4/500 internal mounting hardware & cables (specify machine and interface).
External box (fan/psu) £75. Morley 16-bit SCSI £149.

5% Discount to education. Delivery on large items £10+VAT
Please add VAT at 17.5% to all prices. Plastic welcome.

THE SERIAL PORT



Our shop in Wells is at
15 Union Street
(Union Street is next to Dixons)

The Serial Port
Burcott Manor, Wells,
Somerset, BA5 1NH

sales@cryton.demon.co.uk

Telephone (0749) 670058
Fax (0749) 670809
Modem (0749) 670030
ISDN (Sonix TA) (0749) 670883



Telephone : (01225) 833266
Facsimile : (01225) 833266

105 Midford Road, Combe Down, Bath BA2 5RX

Micro Laser Designs is an Authorised Acorn Publishing and Consumer Dealer. All prices shown exclude VAT. Carriage is FREE on all orders over £25, otherwise please add £2.50. Prices and specifications are subject to change without notice. E&OE. Please call for prices on other items.



ACORN COMPUTERS

ACB15 RISC PC 600 2M HD210 + AKF60	£1249
ACB25 RISC PC 600 5M HD210 + AKF60	£1399
ACB45 RISC PC 600 9M HD420 + AKF60	£1699
Upgrade to AKF85 17" Monitor	£400

RISC PC Limited Period Special Offers: Choose **ONE** of the following :

- **FREE RAM Upgrade** (Extra 4Mb RAM with ACB25/45, extra 2Mb with ACB15)
- **FREE VRAM Upgrade** (Extra 1Mb)
- **FREE 3 year on-site warranty**

A3010 Action Pack	£254
A3020 FD System Med Res Multiscan	£715
A3020 FD System High Res SVGA	£750
A3020 HD60 System Med Res Multiscan	£865
A3020 HD60 System High Res SVGA	£900
A4000 HD210 System Med Res Multiscan	£890
A4000 HD210 System High Res SVGA	£930
Early Years Pack	£42
Learning Curve Pack	£42
Home Office Pack	£85

MONITORS

Goldstar GS1455D 14" 0.39 dot pitch, 1024 x 768	£179
Goldstar GS1461D 14" 0.28 dot pitch, 1024 x 768	£219
Sony CPD-15SF1 15" Trinitron 0.25 dot pitch, 1280 x 1024	£349
Sony CPD-1730 17" Trinitron 0.25 dot pitch, 1024 x 768	£795
IDEK MF-8115 15" 0.28 dot pitch, 1280 x 1024	£275
IDEK MF-8617A 17" 0.26 dot pitch, 1600 x 1200	£585
IDEK MT-9121 21" 0.30 dot pitch, 1600 x 1200 remote control	£1375

RISC PC MEMORY

4Mb SIMM	£115	1Mb VRAM	£129
8Mb SIMM	£225	2Mb VRAM	£199
16Mb SIMM	£425	1 - 2 Mb U/G	£105
32Mb SIMM	£825	All our SIMMS adhere to Acorn Spec.	

HARDWARE

ScanLight Junior 256	£149	TV Tuner incl. teletext	£155
ScanLight Junior 256 for A3000 / A4000	£159	Eagle M2 Card	£319
ScanLight Video 256	£210	Lark Card	£189
Pioneer 604 CD ROM drive	£949	Midi Max Card	£65
Pioneer 602 CD ROM drive	£489	GreyHawk	£95
Wacom ArtPad (A6) incl. drivers	£164	Hawk V9 Mark 2	£189
Wacom A5 tablet & drivers	£379	Chroma Genlock CG3,4,5,6	£145
Wacom A4 tablet & drivers	£529	Chroma 150	£125
ColourCard Gold	£189	Morley SCSI Card	£139
Movie Magic	£239	Morley cached SCSI Card	£189
TV Tuner	£85	Network Cards	£POA

Epson Stylus Colour Printer + TurboDriver (720dpi) £425

Epson GT6500 Scanner, 1200 dpi A4 with TWAIN driver / ImageMaster £525
Epson GT9000 Scanner, 2400 dpi A4 with TWAIN driver / ImageMaster £975
Canon IX4015 Scanner, 1200dpi A4 with TWAIN driver / ImageMaster £595

SOFTWARE

Photodesk	£153	TurboDrivers	£47
PhotoTouch	£63	Compression	£37
Advantage	£49	Formulix	£65
Rhapsody 3	£79	WordWorks	£37
ProArtisan 2 CD	£129	AudioWorks	£45
Impression Style	£95	Clip Art CD 1 or 2	£19
Impression Publisher	£149	MacFS	£95
Publisher Plus (full package)	£250	MacFS Light	£45
Publisher Plus (upgrade from Publisher)	£110	Graphics Loaders	£37
ArtWorks (CD or Disc)	£139	Complete Animator	£89

Every year, from late September through October, secondary schools hold open evenings for the parents of prospective pupils. They do this to help parents decide which school they should choose for their offspring. It is important for schools to keep their pupil numbers up because a school's income depends on its intake, and as a part of the farce of using market forces to improve education – much like advertising improves washing powder – schools are obliged to compete with each other for pupils.

Prospective Parents' Evenings (parents are more important than pupils when they are prospective) allow parents to visit all the local schools and compare them before invoking Parental Choice. The number of schools available for a parent to compare will vary depending on geographical location and population density. It could involve half a dozen schools, although many parents will have no choice at all.

The format of the evening is much the same, no matter which school you visit. There will be handouts, a talk, guided tours, departmental set pieces and simulated lessons. The refreshments, and the sale of second-hand uniforms, will be organised by the parents' association to the accompaniment of the school band.

The problem

The guided tours are similar to being in a game of *Caterpillar*, with a Year 9 pupil as the head, parents attached as body segments, and you have to visit all the locations before going on to the next level. The caterpillar weaves its way along corridors and up and down staircases, and segments are shed from the main body as parents get left behind

Prospecting for parents

When a school has an open evening for prospective parents, it wants to impress. David Watkins examines how Acorn machines can be used to show off your school.

talking to teachers or looking at the displays. Other segments are gained as caterpillars collide at intersections and parents suddenly find themselves inadvertently retracing their steps with a different Year 9 guide.

Meanwhile, discarded body segments are wandering around looking for their lost heads, or trying to get back to the hall in time for the Head's talk. The situation is impossible for any parent with a mobility problem. Back at the hall, the talk by the Head, and possibly the Chair of Governors as well, is a nightmare for anyone with impaired hearing. It is rare for the organisation of a Prospective Parents Evening to include provision for anyone with a disability, even though over 20 per cent of parents are so affected.

The solution

There is no need to change the organisation of the Prospective Parents' Evening for those parents with full mobility and

reasonable hearing – except, maybe, to replace the Year 9 guide with a member of staff who actually knows about the school organisation, the timetable and the curriculum. Some prospective parents, who have older children already at the school, will want to see them helping out in the Science Department, or whatever. The problem is to provide a view of the school and its components for those people who cannot manage the tour.

It will not be long before a model of the school is built in cyberspace and parents can take a virtual tour of the institution, but at present, the best way to show the school to people who cannot play *Caterpillar* is on video. Almost every school has a camcorder and a videoed tour could easily be produced to show the whole school in action to those who opt to miss the actual tour.

Actual lessons rather than simulations could be used, the parental chaos in the corridors would not happen, and the presentation could be planned, rehearsed and edited. Seeing a school in action rather than in simulation is more honest, has a more powerful impact, and is much more valuable to parents. With the tour on video tape you can be sure that everyone gets the same, intended message about the school. What is more, you can include aspects that would otherwise not be available, like interviewing individual pupils at work.

The Head's talk is likely to contain comment about the school's past examination results, its facilities and the proposed curriculum. A video provides an ideal opportunity for subtitling, so that the whole audience gets the message. The inclusion of animated graphics might even make the statistics interesting.

The video tape is easily duplicated



A title screen produced with Titler.

and copies could be made available to parents unable to attend the meeting or to feeder schools as part of the liaison. It could be shown in the school to small groups in much the same way that classes watch videos, or a video projector could be hired for much larger audiences. Income might even be derived from hiring out copies throughout the year.

Where does the Arc feature?

The need for subtitling has already been identified and the Arc's high definition outline fonts and graphics are ideal for this. You can generate title sequences, section headings, captions, labels and credit lists; everything, in fact, that you would expect from a professionally-produced video. In addition to the stunning visuals possible, the Arc can also be used to sample music and sounds which can be used to enhance the production.

A full video editing suite costs thousands of pounds, but much of the basic equipment is likely to be in school already. In addition to a camcorder and video recorder you need an Arc fitted with genlock and a selection of software titles. These will include drawing and painting packages which you will already have, a ray-tracing application like *Render Bender 2* and a titling and sequencing suite like Clare's *Titler*. If the Arc was fit-

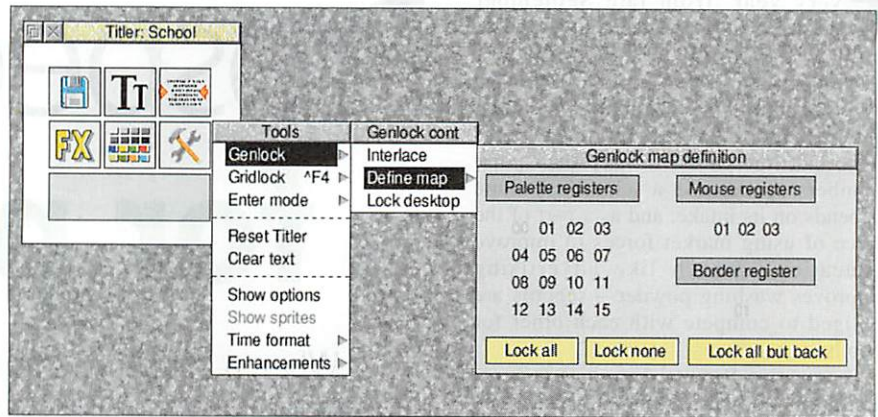

Titler's genlock control.

ted with a CD-ROM drive, it would enable audio CD to be sampled and edited as well.

Genlock allows the output from a computer to be overlaid on to a video signal and the combined output to be saved on a video recorder. One colour from the computer, often black, is made transparent and does not overwrite the original picture. The rest of the computer output is superimposed on the picture.

The basic set up consists of the video signal from a camcorder connected to the genlock input on an Arc, and the output from the genlock connected to the video input of a video recorder. The camcorder sound output is connected directly to the video recorder. Alternative sound sources

can be used and an audio mixer will allow these to be combined. As finances and expertise improve, an additional video recorder and a video editing desk can be added.

can be used and an audio mixer will allow these to be combined. As finances and expertise improve, an additional video recorder and a video editing desk can be added. A number of other formats including *ArtWorks*, *ProArtisan* and *Render Bender*. In *Sequencer* a group of screens, created in *Titler*, are arranged and displayed with a variety of effects including fades, wipes and pauses. Subtitles can be made to scroll across the screen in time with the spoken word, or to appear in synoptic chunks of text, sentence by sentence. *Sequencer* also accepts animations from *Render Bender* and films from *Euclid*.

The advantages and the spin-offs

The production of a 30-minute video is a major undertaking and almost every member of the school can be involved at some stage or other. Parents have much to contribute as well, and their expertise can be called upon. Joint ownership of the production will strengthen positive local attitudes and improve opinions of the school.

Mistakes can be edited out, fluffed lines reshot and the unforeseen absence of key participants can be avoided. October evenings are dark and often wet but on video, prospective parents will see the school on a good day. The sun will be shining, the sky will be blue and the flower beds will be full of blooms.

Parents with mobility problems, or those with impaired hearing or sight, will be able to appreciate the school as never before. They can even borrow a copy of the video and watch it in the comfort of their own home. Parents of pupils already at the school may wish to buy copies of the video, especially if their offspring are in it, and the income generated could go towards funding the initiative for the following year.

As video production increases, to supplement Prospective Parents' Evenings, it won't be long before a school is awarded the Golden Text Book of **AU** Montreaux.

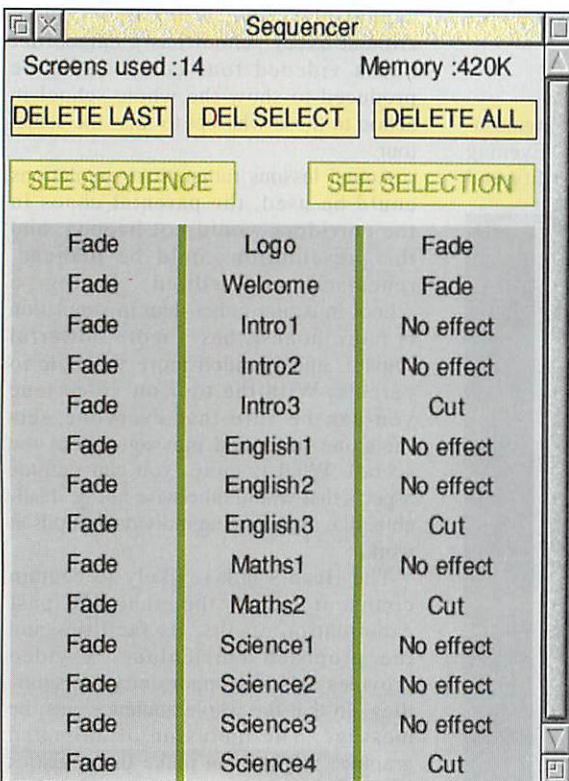

Building a sequence in Sequencer.

can be used and an audio mixer will allow these to be combined. As finances and expertise improve, an additional video recorder and a video editing desk can be added.

Once the planning and shooting have taken place, and the order of scenes decided, the editing and titling can begin. You might consider producing versions of the video using other languages for the titling and subtitling, for those parents who speak English as a second language.

Clare's *Titler* lets you create and edit screens of text and graphics which can be manipulated in the *Sequencer* support application. Text is created and displayed with the highest precision and a wide range of effects, such as drop shadows and delayed display. Graphics can consist of sprite and *Draw* files and

AUTO PRINTER SHARER



**ONLY
£39.00**

- Simple two-to-one automatic printer sharing switch.
- Alternative to unreliable manual switching. No power needed.
- Connects to all printers with a parallel Centronics® interface.
- Suitable for Acorn Archimedes and PC computers.
- Complete with cables 2 x 1.5m + 0.2m to printer. Made in U.K.

TERRELL ELECTRONICS

7-B Essex Gardens, Hornchurch, Essex, RM11 3EH
☎ 01708 471426. Prices are carriage paid excl. VAT

Part Exchange to RiscPC

Prices of New Risc PC Computers

Risc PC600 2M 2Mb RAM, 210Mb HD	£1249.00
Risc PC600 5M 4Mb RAM, 210Mb HD, 1Mb VRAM	£1399.00
Risc PC600 9M 8Mb RAM, 420Mb HD, 1Mb VRAM	£1699.00
17" monitor option add	£ 400.00
4Mb RAM u/g add	£ 125.00

Typical Trade in Allowances

A3000	£200
A310	£200
A420/1	£275
A440/1	£325
A4000	£450
A5000 2/40Mb	£525
A5000 4/80Mb	£600
A5000 4/160Mb	£650
AKFI/12/17/40	£ 65
AKF8	£ 95
AKF50	£ 150

Subject to change, please phone to confirm

Collection and delivery service for part exchanging computers - £30.00

Hard Disk Part Exchanges

For A5000, A4000, A3020 and RiscPC

40Mb to 170 Mb	- £ 99.00
40Mb to 250 Mb	- £ 119.00
40Mb to 420 Mb	- £ 169.00
80Mb to 170 Mb	- £ 79.00
80Mb to 250 Mb	- £ 99.00
80Mb to 420 Mb	- £ 149.00

210Mb to 420 Mb	- £ 129.00
60Mb to 240Mb	- £ 149.00

Software transferred free.

A410 and A310 Upgrades

20Mb to 40MB IDE inc i/f	- £109.00
20Mb to 80MB IDE inc i/f	- £129.00
20Mb to 210MB IDE inc i/f	- £199.00
40Mb to 80MB IDE inc i/f	- £199.00
40Mb to 210MB IDE inc i/f	- £179.00

Software transferred free.

AJS Computers

123 New London Road
Chelmsford Essex CM2 0QT
tel 01245 345263
fax 01245 345233
all prices plus vat



PREMIUM BULK 3.5" DISKS

	DS/DD	DS/HD
50	12.49	15.86
100	22.49	29.38
200	44.49	56.40
250	54.99	64.63
500	107.49	117.50
1000	199.75	223.25

ALL DISKS ARE CERTIFIED AND COME WITH OUR REPLACEMENT OR MONEY BACK GUARANTEE

All products are subject to availability.
All prices include VAT.

For disks and boxes please add delivery charge:
4 days £3.50
24 hours £5.00.
E&OE

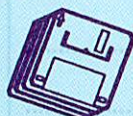
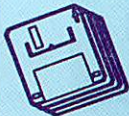

SNAP COMPUTER SUPPLIES LTD

HOTLINE

01 703 457111

3.5" SUPERIOR LOCKABLE DISK BOXES

Qty	100 Cap.	140 Cap.	200 Cap. drawer
1	4.49ea	6.49ea	New 11.95ea
2	4.39ea	6.39ea	11.75ea
4	4.19ea	6.19ea	11.50ea
6	3.99ea	5.99ea	10.95ea

RIBBONS - POST FREE

Full Mark Brand	2 off	4 off
Citizen 120D/124D Swift 24	PRICE EACH	2.55
Citizen Swift 24 Colour	2.75	11.95*
Panasonic KXP 1080/1123/1124	3.25	3.05
Panasonic KXP 2123	4.95	4.75
Panasonic KXP 2123 Colour		10.95*
Star LC10/LC20	2.60	2.40
Star LC10-4 Colour	5.50	5.25
Star LC24-10	2.95	2.75
Star LC24-10 Colour		9.95*
Star LC200	3.00	2.80
Star LC200 Colour		9.95*
Star LC24-200	2.95	2.75
Star LC24-200 Colour		9.95*
Minimum order - 2 ribbons, except those marked with an asterisk*		
HP Deskjet 500 Single Refill		7.99*
Canon BJ10E Double Refill		7.99*
Canon/HP Colour Refill		11.99*



SNAP COMPUTER SUPPLIES LTD. Fax: 01 703 457222
Unit 12, The Sidings, Hound Road, Netley Abbey, Southampton SO31 5QA



Next Month

in ACORN USER



Cover CD-ROM

As you would expect from *Acorn User*, we're going to be the first Acorn magazine to feature a cover-mounted CD-ROM disc, absolutely free. The *Acorn User* CD-ROM will be jam packed with all sorts of goodies, from the pick of the Public Domain and the entire Acorn ftp site to a complete issue of *Acorn User* in *Impression*.

We'll also be including loads of demos from commercial software houses, so you can try before you buy, and there will even be locked software that you can unlock by paying for it with a credit card over the phone, so you don't have to wait for delivery.

All this, in addition to a packed cover disc and the best selling Acorn magazine in the world. What more could anyone want?

Graphics galore

It's time for the graphics round-up of the year. How do the new 24-bit packages compare one year on, and how do they compare with *PhotoShop*? We look at the present state of graphics and predict what will happen in the Acorn scene over the next few years.

Absolute beginners

Our popular series for those new to computing returns after a year's absence, so if you're confused by mice, windows and icons, don't miss the first part.

To be sure of your copy, please fill in the coupon below and hand it to your newsagent. Or why not take out a subscription, which includes a gift pack. See the Subscriber's Page for details.

Dear Newsagent, please order my regular copy of *Acorn User*

Name

Address

.....
.....

Acorn User is published by IDG Media Ltd, Media House, Adlington Park, Macclesfield SK10 4NP
Distributed by COMAG, (01895) 444055

**NEXT
ISSUE**
**ON SALE
27 MARCH**
DON'T MISS
your issue of
Acorn User

Some more perceptive users of Acorn systems have escaped from the shackles and constraints of being just ordinary.

They have found a source of information, ideas and inspiration for publishing, design & multimedia beyond compare in the Acorn world.

Join them and find out just how much you have to gain.

It's simple

Acorn Publisher

the best kept secret of 1994 that everyone is talking about in 1995.

Have you seen a copy yet?

Be in the know – write or phone now

AKALAT Publishing

P.O. Box 231, Barton, Bedford MK45 4HQ.
Tel. 01582 881614 fax 01582 881614

Artwork by Walter Briggs from issue three of Acorn Publisher.

TableCalc The OLE spreadsheet

- Point and click expression editing
- Multiple user definable styles
- Comprehensive button bar
- Export as Draw and CSV files
- Full OLE links with Impression
- Math functions
- 24 bit colour
- Interactive help

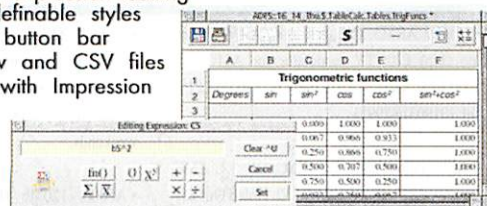

TableCalc £31.50 including carriage

XStitch The cross stitch designer

- Make cross stitch patterns from any sprite
- 64 colours per pattern
- Exports draw files
- Automatic grid
- Calculates number of stitches
- Supports 14, 18 & 22 hpi
- Calculates stitching time
- Colour and Mono patterns

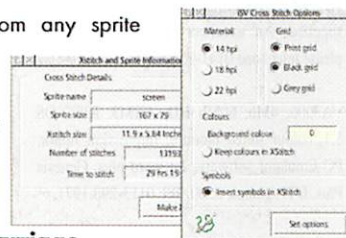

XStitch £21.50 including carriage

Also available

DrawWorks (extra features for Draw) £16.50 including carriage
Font Designers Toolkit £31.50 including carriage
Font Pack 277 £26.50 including carriage
Demo disk and catalogue £2.00

86 Turnberry, Home Farm
Bracknell Berks RG12 8ZH
Tel 01344 55769

iSV
Products

SENLAC Computing

PO Box 304
Brighton
BN1 1LE

Callers by appointment

Tel: (01273) 208074

Fax: (01273) 738258

e-mail: sales@senlac.demon.co.uk

CompuServe: 100113.603



Big news this month is our 32Mb SIMMs for just £799! That's a saving of over £300

on our previous price! We also hope to soon have larger SIMMs available - phone for details.

We can show only a tiny fraction of our range so if you don't see what you want please call.

Phone or fax any time of the day or night - even if we have to sleep our answering machine stays awake!

We can accept Access, Mastercard, Visa, Delta, cheques, cash, etc..

Pete Sykes

Acorn

Pocket Book II

Pocket Book II (256k)	255.00
Pocket Book II (512k)	315.00
A-Link	49.00
Mains Adapter	14.50

♦ ♦ Limited Special Offers ♦ ♦

Ask about our music bundles

USR Sportster 14,400 Modem+Cable ...	165.00
USR Courier v34 Modem + Cable	395.00

Games

Arcturus	22.50
Cannon Fodder.....	21.50
Crystal Maze.....	36.50
Diggers	27.95
Dune II	32.50
E-Type 2.....	29.25
Flashback.....	24.95
FTT (Formula 2000)	23.25
Lemmings for Risc PC.....	25.50
Lemmings 2 - Tribes	25.50
Sim City 2000 (Risc PC)	35.00
Simon the Sorcerer.....	35.95
Speedball 2	21.75
Star Fighter 3000.....	27.00
Sprobleoids.....	22.95
Wolfenstein 3D.....	27.00

Music/Sound

Lark A16 Card.....	225.00
Serenade	88.00
Sibelius 6	165.00
SSES 1600	call
Rhapsody 3.....	88.00

Other Goodies

ArcFax.....	165.00
Artworks.....	165.00
Eagle M2	360.00
Hearsay 2	165.00
ImageFS	34.95
Impression Pub.....	145.00
Impression Style	88.00
Personal Accs. v3.....	43.00
PhotoDesk	180.00
Squirrel 2	160.00

All prices include VAT and UK P&P - there is no more to pay.
PO Cash on Delivery add £8 (available for orders up to £500 only).
Errors and Omissions Excepted (E&OE).

Risc PC 600

ACB15 Risc PC 600 2Mb/HD210	1400.00
With 17" Monitor.....	1870.00
ACB25 Risc PC 600 5Mb/HD210	1560.00
With 17" Monitor.....	2030.00
ACB45 Risc PC 600 9Mb/HD210	1900.00
With 17" Monitor.....	2370.00

All Risc PCs include 1 year's free on-site maintenance.

Systems without monitors are available in some circumstances. Please call for details..

Schools/ Businesses

Lease a Risc PC from as little as £43.50 per month over 3 years. Call for details.

Paying by Cash, Cheque or Delta?

You may deduct an

extra £35 discount

from the VAT inclusive price of your Risc PC!!

A selection of Risc PC bits 'n' pieces...

210Mb 2nd IDE Drive Kit	199.00.
420Mb 2nd IDE Drive Kit	270.00.

16Mb SIMM.....495.00

32Mb SIMM....799.00

Stop Press!!

SENLAC are now also able to supply the complete range of orange™ digital mobile phones and accessories! We have some very special deals available...
...Please call!

orange™

Free Ads

- 25MHz ARM3, CJE, £70 ono, ARM3 board (no chip) £20, TV modulator for A310/400/3000 £25, ARM2 £15, RISC OS 2 ROMs £15, Tel: (01903) 879931.
- A310 colour monitor, RISC OS 3.1, 2Mb memory £250, Pipedream 3 £30, Holed Out £5, Fascia for 2nd floppy plus leads £15, Alphabase £10 + postage. Tel: (01508) 578189.
- A3010, 2Mb, 120Mb HD, software, games and dot matrix printer, all cables and manuals supplied. An excellent system! Price £500, please telephone 0141-954 8337.
- A3000, 4Mb, 60Mb HD, ARM3, RISC OS 3.1, colour stereo monitor, Impression Junior, PC Emulator software, 1st word plus, Genesis Plus, DTP, games, £500. Tel: 0113-293 1971.
- Clearout! Easy C £20, Premier Manager £10, Oak Recorder £20, Acorn magazines plus disc 50p, phone Barrie on (01934) 832355 evngs.
- Acorn A5000, 4Mb, IDE 240Mb + 40Mb HD, standard monitor, MIDI Podule, bundled software incl. PC Emulator with DR DOS, Windows 2.1, Star LC24-10 (24-pin), £1000. Tel: 0131-228 2052.
- Two joystics with Acorn printer port interface, excellent condition, £30. Tel: (01761) 462810 after 6pm.
- A5000, colourcard gold, 15 inch multisync monitor, 50Mb hard disc, 4Mb RAM, perfect condition, boxed with all manuals, £850 ono. Tel: (01389) 765560.
- Serial port interface, control pads, joysticks, and many great games such as: Elite, Chuck Rock, Technodream, Lemmings and SWIV at excellent prices. Tel: (01279) 504237.
- A4000, multiscan monitor, Cumana CD-ROM plus EMU and CDs, 250Mb HD, Joystick, 4Mb RAM, lots of software, £1000. Tel: (01884) 252413 evngs. ask for Stewart.
- BBC B 32K computer, DFS, tape and disc drives, Epson printer, AMX mouse, books, manuals and software: games, WP, database, spreadsheet, £200. Tel: (01763) 288266 weekends.
- A5000, 120Mb HD, RISC OS 3.1, 8Mb RAM, multisync.
- BBC B, OS 1.2, twin 40/80 discs & RAMdisc plus Wordwise+, Dumpout, Exmon & Toolkit-ROMs & manuals, Epson RX80F/T+ printer. All leads. Perfect. £170 ono. Tel: (01895) 444410.
- A440/1, ARM3, RISC OS 3.11, 47Mb HD, Pineapple colour digitiser, Acorn I/O card £600 ono. Tel: (01869) 340488 weekends.
- BBC B, dual 40/80 floppy, 6502 second processor, mono monitor, ADFS, books, software, £125 (may split). Tel: Rob (01344) 51006.
- Acorn A3000, 120Mb HD, 4Mb RAM, RISC OS 3, colour monitor, monitor stand, learning curve software, games, joysticks and interface, £499. Tel: Max 0121-351 1381 (Birmingham).
- A5000LC, 2Mb RAM, 40Mb HD, RISC OS 3.0, Acorn AKF18 multiscan monitor, £700 ono. Tel: 0171-701 6441.
- New Irlam 24i16 video/sound card (Feb 1995) - 1Mb VRAM full frame version - £370. Colour card Gold £160. Scanlight video 256 £150. Tel: Iain (01463) 751251.
- A5000 LC, RISC OS 3, 2Mb RAM, 40Mb HD, PC Emulator, AKF18 multiscan monitor, manuals, software, mint condition, little used, £850 ono. Tel: Manchester 0161-707 6019.
- A5000, 4Mb RAM, 120Mb HD, ARM3 (25MHz) RISC OS 3.1, multiscan monitor, hand scanner, lots of software including Publisher, ArtWorks, Fireworkz - £800. Tel: 0151-334 5115.
- BBC Master, colour monitor, disc drive, Hybrid 4000 synth, 4 octave music keyboard, all manuals £180 ono. Tel: (01242) 239000.
- Wanted urgently: Omar Sharif's bridge. Tel: (01722) 323718 (ans/fax).
- A 410/1, 4Mb RAM, 20Mb HD, ARM3, RISC OS 3.1, monitor, sound sample/MIDI card, joysticks, various manuals, software, podule development card £650. Tel: (01452) 417597.
- Risc PC 600, 4Mb DRAM, 1Mb VRAM, no monitor, 210 Mb HD, new unwanted gift, offers please. Will exchange for Commodore Vic 20. Tel Simon: (01223) 329121.
- A3000, immaculate condition, colour monitor, 2Mb upgrade, Learning Curve, Genesis, PC Emulator, word processor, Lemmings, Pacmania. All manuals including DOS v.g.c. Panasonic matrix printer £600. Tel: (01502) 565833.
- BBC B Issue 7, colour monitor, ROM/RAM, Challenger DD Drive/RAM disc, Intersheet, Publisher, Replay, Wordwise+, Beebug C, other ROMs, software, manuals, books, magazines, and more. £200. Tel: (01525) 371254.
- For sale: 'Four' joystick interface for Archimedes £15. Wanted - 'The Pawn' and 'Guild of Thieves' adventure games, also copies of 'Beebug' or other BBC magazines. Tel: (01670) 531545.
- For sale: Joysticks - 2 Quickshot Pythons and one 'Arcade Style' stick. Also Saloon Cars, Pandora's Box, Enter The Realm, Populous, Lemmings and Rotor. All £5 each. Tel Adam on (01278) 652 038.
- A410/1, RISC OS 3.1, 4Mb RAM, ARM3, VIDC, Oak SCSI board, 47 Mb internal HD, 105Mb external HD, Eizo 9060s monitor, boxed, manuals, £700. tel: (01325) 463873.
- A410/1, RISC OS 3.1, 35MHz ARM3, 228 Mb SCSI HD, state machine G16 graphics card, HCCS 16-bit SCSI card, monitor, MIDI, s/w, £650. Tel: 0161-655 0399.
- Dungeon £25, Black angel £15, Tel: (01232) 665063 evngs.
- Master 128, 40/80 Cumana disc drive, full view family ROMs, LISP, other software, books, Voltmace twin joystics £250 ono. Tel: (01932) 562281.
- Acorn A4000, 80Mb HD, 2Mb RAM, Multisync monitor, all manuals + leads + boxing; Excellent condition + Artisan 2 + loads of PD. Only £650. Tel: Adam on 0171-720 3591.
- A3020 and A3000 for sale: A3020 £700, A3000 £400 with lots of extras or £400. Will swap both for A540 or A5000 with extras. Call: (01908) 274478.
- Eureka 2, ProArtisan 2 and Revelation ImagePro, each £55 (approx half price). Tel: Iain (01463) 751251.
- A3000, 2Mb, colour monitor, 68Mb HD, second floppy drive plus card, Star LC10 colour printer, RISC OS 3.1, Learning Curve etc. £550 (01428) 723387.
- A5000 LC, 4Mb RAM, 40Mb HD, RISC OS 3.1, DTP, FW+, Genesis, PCEm 1.7, PD, manuals, vgc., £950 or offers. Tel: (01242) 238531 evngs/wends.
- A3000, 2Mb RAM, RISC OS 3.1, colour monitor, scanlight junior £350 ono. HP DeskJet £100 ono. Tel: (01235) 817139.
- A4, 4Mb/60Mb HD, excellent condition, £1000 ono. Atomwide SCSI interface £75. Tel: (01799) 530987 (evngs), 524224 (day).
- A310, colour monitor, LC10 printer, all leads, software, manuals and PC emulator £250. Tel: (01903) 690036.
- Psion 3a; 512k RAM; original packaging, manuals; A-Link and mains adaptor; £250. Tel: 0131-447 8624.
- A5000, 4Mb RAM, 124Mb IDE HD, RISC OS 3.11, Acorn multiscan monitor, lots of software, £900 ono. HP 550C colour inkjet printer £300 ono. Tel: (01703) 324980.
- Flashback £15, Lotus Turbo Challenge 2 £12, Zool £10, Tel: (01603) 754746 evngs.
- BBC master 80T Cumana disc drive, co-processor, W/E NLQ, ViewSpell, View Professional, Epson FX80 FT, Z88 portable computer, 2x128k RAM, carry case, £250. Tel: (01689) 873755 or 071-515 4242 (Iain).
- A440/1, monitor, ARM3, RISC OS 3.11, I/O podule, digitiser. £650 ono. Tel: (01869) 40488 weekends.

Acorn User Free Ads Service

Why not take advantage of our free reader ad service? Fill in your details on this coupon (25 words maximum, one word per box below) and send it to Free Ads, Acorn User, IDG Media Ltd, Media House, Adlington Park, Macclesfield SK10 4NP. Only one ad per reader, please. Although we try to publish every ad we receive, we can make no guarantees; publication is entirely dependent on space and time constraints. We may also publish free ads on the cover disc if magazine space is short. Please fill in your name and telephone number below: these will not be published, but they enable us to contact you in case of any queries.

Your name _____ Telephone no _____

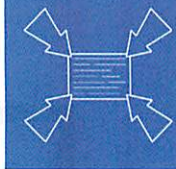

- Acorn Electron games. Over 100 originals including Predator, Jet Set Willy, Strykers Run, Thunderstruck etc. Sell or swap separately. Tel: (01733) 891312.
- A3000, 2Mb RAM, RISC OS 3, colour monitor, additional floppy drive, manuals. Lots of software including Learning Curve. £375 ono. Tel: (01905) 358509 evngs.
- Acorn A4 portable, 4Mb RAM, 60Mb HD, genie trackerball, original packaging, PCEm, manuals & carrying case £1100. Tel: (01309) 641386.
- A440, 4Mb, 20Mb HD, ARM3, RISC OS 3.1, Acorn 14in monitor, operating manuals, £450. Cumana 5.25in drive with w/f. AKA10 User Port backplane. Offers. Tel: 0181-398 6401.
- Acorn Advance, integrated package (Wordprocessor, spreadsheet, database, graph), RISC OS 3.1, retail £85 + VAT, price £50 + p.p. PC Emulator + DR DOS 6.0. £25 + p.p. brand new. Tel: (01925) 730530.
- Chuck Rock, Pandora's Box, Cyborg: £8. Lotus 2: £10. VT Joystick interface £10. Genesis £20. Tel: David on 0191-253 1883.
- Fax Pack £300, Colour Card Gold £250, Armadillo stereo sampler £50, Tel: 0181-994 7659 after 6pm, W London.
- A5000, 4Mb RAM, 120Mb HD, Multiscan monitor, games, over 80Mb PD software, excellent condition £850. Tel: (01904) 769526.
- Archimedes A305 upgraded to 2Mb RAM, 40Mb HD. Excellent condition, no monitor, hence only £250 ono. Tel: (01706) 813441.
- A5000, 4Mb RAM (expandable to 8Mb), 40Mb HD, twin floppies, sampler + MIDI interface, colour card gold, software, Taxan 775 multisync, boxed, as new, £1100. Tel: (01704) 563344.
- A305, 4Mb RAM, 40Mb HD, RISC OS 3.1, colour monitor, PC emulator, lots of magazines, £££ of software, including many games, £525 ono.
- A5000, 4Mb/40Mb, ARM3, AKF18, RISC OS 3.11, requires repair, £525. A440, 4Mb/40Mb, ARM3, AKF17, RISC OS 3.11, £475. A420, 2Mb/20Mb, AKF17, £475. A420, 2Mb/20Mb, AKF17, £400. Excl. delivery. Tel: Tamworth (01827) 330118, evngs, wends.
- Games: Microdrive 2, SR2000 tracks, Virtual Golf tracks, Saloon Cars @ £10 each. Iota TouchType, EasiWord, Impression Junior, A3010 2Mb @ £20 each, Twin World, Quest for Gold @ £5 each, Citizen Swift 24, £160. Tel: Garth on (01247) 458919.
- A410/1, 4Mb, RISC OS 3.1, 36MHz ARM3 (17 MIPS), Multisync monitor, IDE interface, software. Good condition, £600. Tel: Rugby (01788) 578201.
- A420/1, 4Mb RAM, 50Mb HD, RISC OS 3.1, VIDC enhancer, 5in drive interface, software, £550. BBC B Aires Sideways ROM/RAM, £125. 40/80 double Cumana disc drive, £100. Tel: (01272) 687297.
- Archimedes A310, 4Mb, ARM3, 163 internal SCSI HD, AFK50 multisync monitor, scanner, joystick, digitiser plus more. Worth over £2200, selling for £750 ono. Call Richard on 0121-454 0281.
- Colour Card Gold £175, Pineapple video digitiser £100, Bank Manager £5, Easiwriter £35, popular games from £2 to £10. Also bundled offers. Tel: (01949) 850380 (evngs).
- Citizen Swift 24 dot matrix 24-pin printer. £60 ono. Tel: 0181-898 0447.
- Acorn A3010 with 2Mb upgrade, HD, Acorn colour monitor, LC Star 100 colour printer, extra software ArtWorks and Impression Junior DTP. Manuals, as new, £650. Tel: Honour 0121-744 7437.
- Virtual Golf £17. Elite £21, Interdictor £5, SparkFS £14. All boxed with manuals. Tel: (01703) 260088 evngs.
- Archimedes A4000, 4Mb RAM, 80Mb HD, PC Emulator card, DOS 6.2, Windows, loads of DOS and Acorn software £900 ono. Tel: (01708) 475960.
- Archimedes hardware: 105Mb HD and 16-bit Morley SCSI interface £225. Armadeus audio sampler £50 - all machines. HCCS vision digitiser for A3000 £50. Tel: 0191-413 1522.
- Acorn Electron, boxed with manuals, cassette deck, a dozen software packs, mainly electronic, aged 7+, £30. Tel: (01494) 722513.
- A3000, 2Mb, RISC OS 2, Vision b/w digitiser, £220 ono, Tel: Shekar 081-360 2629 evenings only.
- Bargains! Top Archimedes titles from 30% of their original price: Break 147, Populous, Saloon Cars Dlx, Sim City, Genesis+, Home Accounts, Spanish, Chartwell. Tel Chris: (01474) 537434.
- A3000, 4Mb RAM, 80Mb HD, RISC OS 3, multisync monitor, software, AU discs, mags, the lot: £700. Tel: Peter, 081-578 3784 evenings.
- A3000, 2Mb RAM, £275. Advance, new, unregistered £70. 4Mb RAM for A3000, £80. Acorn DTP, £30. Compression £15. 1st Word + (release 2) £20. Tracerball £12. HCCS TV Modulator (for A3000) £20. Tel: (01942) 870584.
- A5000, 2Mb RAM, 2 x IDE HDs - 250Mb + 80Mb, Aleph One 486 card (4Mb RAM). Some software, sell for £2000. Tel Andrew after 5pm on 0181-348 6944.
- A3000, 2Mb RAM, VGC colour monitor, Learning Curve including Genesis, PC Emulator, word processor, Fun School 2-3-4 plus other games. All manuals, hardly used. £450 ono. Tel: (01443) 204801.
- A5000, 4Mb RAM, 40Mb HD, RISC OS 3.11, AKF18 multiscan monitor, Learning Curve software, good condition, superb value at just £700. Tel: (01849) 422861.
- A3000 colour monitor, 4Mb, RISC OS 3.1, massive 270Mb SCSI HD in PRES housing with second disc, £850. Photo CD-ROM, AKF50 multisync bundled with above, £1299. Free printer. Tel: (01332) 702779.
- Computer Concepts' TurboDriver for Hewlett-Packard 500 series printers, £25. ExpLAN Event desktop diary application (unregistered) £15. Tel: 0131-447 8624.
- A5000, OS 3.1, 240Mb HD, 4Mb RAM, AKF18, multisync monitor, PC emulator, immaculate condition, £850 ono. Tel: Oxford (01865) 326641.
- Archimedes 420/1, monitor, 4Mb RAM, 40Mb hard disc, RISC OS 3.1, ARM3 boxed with 20 games, £450 ono. Tel: 0181-567 3577, London, office hours.
- BBC Compact, colour monitor, keyboard plus Citizen 180E printer with original packaging. For sale, any reasonable offers. Evenings, weekends, Tel: Watford (01943) 864694.
- A3000 RISC OS 3.1, 4Mb RAM, 20Mb HD, Philips 14in monitor, Panasonic 24-pin printer, CC Scanlight, Impression Publisher, Graph-Box, all manuals, many more programs, £700. Tel: (01703) 340387.
- Wanted: Watford monochrome video image digitising boards for Acorn Archimedes, for use in body scanner used for detection and treatment of scoliosis. Reasonable offers considered. Tel Dr Groves: (01925) 571392 or (0836) 644145.
- The Dungeon - maps and puzzle solutions for all 14 levels available. Send £4 made payable to John Parker to 57 Firtree Grove, Sutton Coldfield B75 5UN.
- A410 2Mb RAM, 20 Mb HD with Acorn AKF11 RGB monitor, all boxed with manuals and original discs, £400. Tel: Oxfordshire (01235) 850360.
- Sound sampler, high quality board from Clares. Samples up to 48.0 KHz (CD/DAT) via line or mic input. Armadeus including editing software (effects, echo etc). Only £100. Tel: 081-491 6169.
- Help! Disgruntled BBC owner! PD software wanted and penpals from anywhere. Write to Neil Parry, 17 Coke Street, Bathside, Harwich, Essex CO12 3HP.
- A420/1, 4Mb RAM, 40Mb hard disc, OS 3.1, ARM3, PC emulator, various software, £500. Standard monitor, £50 extra. Tel: (01962) 712505.
- Vertical Twist joystick interface v2.4, unwanted gift, in original packaging, as new. £30 ono. Tel: (01623) 755455 after 7pm.
- ScanLight 256, complete £100; Acorn MIDI podule & EMR Studio 24plus version 2, £80; Oak SCSI podule & hard disc 45Mb cased + p/u, £80; Impression Publisher, £75. Tel: (01493) 740557.
- A410, 4Mb ARM3, RISC OS 3.1, 47Mb HD, colour monitor, Oak SCSI interface, 5.25in FD interface, cables, manuals, boxes, software, games, £750 ono. Tel: 081-778 9166.
- BBC Master Compact, 3.5in drive, some software, £120. Tel: (01428) 723387 (Hampshire).
- A3000, Learning Curve, 2Mb RAM, RISC OS 2, Philips CM8833 monitor, colour printer, software, boxed as new, £590 ono. Contact Bernard on 0171-477 8910.
- A3000, 2Mb, RISC OS 3.1, colour monitor, printer, Learning Curve, software and games, all boxed. Phone Phil on (01273) 205238 evenings, £450 ono.
- Games for sale: The Exotic Adventures of Silvia Layne, Xenon 2, £10 each. Twin World, £5. Tel: (01227) 368287.
- A3000, 80Mb HD, hand scanner and multisync monitor, with all manuals and with loads of software. £580 ono. Tel: (01257) 450401.
- 'A540 spec' Archimedes, 35MHz, ARM3, cached SCSI, 4Mb RAM, RISC OS 3.1, 170Mb HD, Philips monitor, PC Em, PC + Arch software, mint, boxed, £890 ono. Tel: (01635) 41738.
- A5000, RISC OS 3.1, 240Mb IDE HD, 4Mb RAM, FPA10 chip, NEC multisync 2A SVGA, HP DJ500 printer + games/manuals, call Grant: (01742) 679830.
- Risc PC 1Mb VRAM £95. ST506 HD controller podule for A300/400 machines £30. 4 slot backplane for A300/A400 £30. Acorn DTP £10. Tel: (01344) 53075 9:30am to 9:30pm.
- A410/1, 2Mb, RISC OS 3.1, 100Mb IDE hard disc, extensive publishing, imaging and audio applications, 9-pin Epson FX80+, hard disc contents, 60 discs, books. Whole package £849. Tel: (01684) 299345.
- Printer: Panasonic KX-P1180 multi-mode dot matrix printer, with printer ribbon. Very good condition £70 ono. Phone Richard (01392) 58500, evngs.

Back issues

Missed out on one of our previous issues? Now's your chance to bring your collection up to date, but hurry: stocks are limited.

Still available: May 1993 to December 1993 (numbers 130 to 137) for £2.80 each. Enquiries to the address on the order form.

Issue 138 – January 1994
OUT OF STOCK

Issue 139 – February 1994
● Programming special
● Sibelius ● C interpreter
● CD-ROM round-up

Issue 140 – March 1994
● Graphics ● Monitor round-up
● OCR packages ● Fireworkz
● PlanING review

Issue 141 – April 1994
● Spring Show ● Eagle M2
● Databases ● Colour scanners
● Using IT in history

Issue 142 – May 1994
OUT OF STOCK

Issue 143 – June 1994
● Public Domain ● Impression
Publisher ● Inside Acorn
● Almanac 3 review

Issue 144 – July 1994
OUT OF STOCK

Issue 145 – August 1994
● Acorn User Awards ● Control
● Bitmap graphics packages
● Elvis PC Card ● Adventure
games ● Prime Solver

Issue 146 – September 1994
OUT OF STOCK

Issue 147 – October 1994
OUT OF STOCK

Issue 148 – November 1994
● Acorn World ● Architech
● The Complete Animator
● CD-ROM round-up ● First Page



Issue 149 – December 1994
OUT OF STOCK



Issue 150 – Christmas 1994
● HomeWorks Spreadsheet
● Impression vs Quark/PageMaker
● MPEG ● ProArt 24 review



Issue 151 – January 1995
● Computing for the Family 2
● Eidos profile ● Installing networks
● Home accounting ● ProjectING

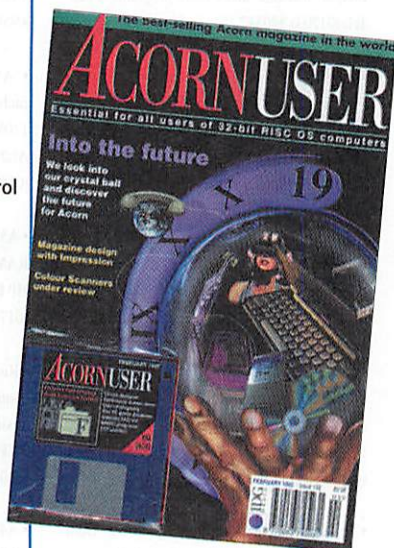

Issue 152 – February 1995

- Gazing into the future ● Magazine design
- Knitting and weaving ● Colour scanners
- Enterprise Accounts ● Pocket Book I vs II
- The ARM Club ● PD CD-ROM 2

Order form

- Issue 139, February 1994.....£3.95
- Issue 140, March 1994.....£3.95
- Issue 141, April 1994.....£3.95
- Issue 143, June 1994.....£3.95
- Issue 145, August 1994.....£3.95
- Issue 148, November 1994.....£3.95
- Issue 150, Christmas 1994.....£3.95
- Issue 151, January 1995.....£3.95
- Issue 152, February 1995.....£3.95

Name

Address

.....Tel No

Please allow 14 days for delivery. Send cheques payable to IDG Media to
Media House, Adlington Park, Macclesfield SK10 4NP
or phone Tracy on (0625) 878888 quoting your credit card number
Visa and Mastercard accepted

TT Turing Tools

149 Campbell Road, Cowley
Oxford, OX4 3NX, UK
Tel. (0865) 775059

SpoilSport

RISC OS 3.x System Defense Kit

"They rename the hard disc... scramble the configuration... turn off the auto-boot... reset the system clock... do factory resets..." The solution is SpoilSport. £30.00 inc.

IronMask 2.1

Multi-user File Security System

'Frozen' directories or application folders are made unchangeable except by the IronMask superuser. 'Shielded' files are made completely inaccessible except to their owners. User authentication. Failsafe encryption. The software solution for RISC OS security in school or office. £55.00 inc.

IronMask 2.1 + SpoilSport £65.00. 10% OFF all prices for prompt payment (14 days).

Prices quoted for 1 computer. British Isles postage included. Overseas add £3.00. Phone for educational and site prices, further information or factsheets. Allow 14 days delivery.

INKJET & BUBBLEJET REFILLS

"CARE THREE PACK" will refill HP Deskjet range 3 times. The Canon Bubblejet range 3 times. Three Pack available in Yellow, Magenta, Cyan, Red, Blue, Green, Brown, Purple, Black £14.98 each.

"TRI-COLOUR PACK" 3 refills of Yellow, Magenta and Cyan £17.95.

"CARE SIX PACK" will refill HP51608A Cartridge 6 times. The Canon BC01/02 etc. Cartridge 6 times.

6 PURE BLACK REFILLS ONLY £24.95

Please state type when ordering

"Print Head Recovery Fluid" for unblocking inkjet/bubblejet cartridges
18ml bottle £5.95

REFILLS AVAILABLE FOR MOST INKJET AND BUBBLEJET PRINTERS

Education orders welcome

COLOUR PRINTER RIBBONS

Reloads for:-
Star LC200 9 Pin 4 Colour (Normal Ink) 1 Reload - £5.95 5 Reloads - £23.50
Star 24 Pin 4 Colour (Normal Ink) 1 Reload - £6.99 5 Reloads - £29.95
Citizen Swift 4 Colour (Normal Ink) 1 Reload - £6.99 5 Reloads - £29.95
Panasonic KXP2180/2123 4 Colour (Normal Ink) 1 Reload - £6.99 5 Reloads - £29.95
Seikosha SL95 4 Colour (Normal Ink) 1 Reload - £6.99 5 Reloads - £29.95
Ink ribbons also available in Gold, Silver, Magenta, Orange, Purple, Brown, Green, Blue, Red for a wide range of printers.
Special re-ink for Panasonic printers, Star LC200 9-pin, Epson LQ100 black bottle will re-ink 100-ribbons £9.95
Don't throw away your plastic printer ribbon cases when the ribbon wears out. Just take the top off, take out the old ribbon and reload it with a new one. It's simple! Full instructions supplied.

T-SHIRT PRINTING

4 Colour Citizen Swift £29.95
4 Colour Citizen Swift (Reload) £14.95
4 Colour Star LC10 £14.95
4 Colour Star LC200 9 Pin £19.95
4 Colour Star LC200 9 Pin (Reload) £12.95
4 Colour Star LC200 24 Pin £29.95
4 Colour Star 24 Pin (Reload) £14.95
4 Colour Seikosha SL95 £29.95
4 Colour Seikosha SL95 (Reload) £14.95
1 Colour Citizen 120D/Swift £11.95
1 Colour Star LC10 £11.95
1 Colour Star LC200 9 Pin £11.95
1 Colour all Star 24 Pin £11.95
1 Colour Epson FX80/LQ400/MX80 £11.95
1 Colour Epson LX80 £11.95
1 Colour Epson FX100 £11.95
1 Colour Panasonic KXP 1080 £11.95
1 Colour Taxan/Canon 1080A £11.95
available for a wide range of printers

All Prices include VAT and Carriage
How to order: Enclose cheques/PO made payable to CARE ELECTRONICS or use Access/Visa.

CARE ELECTRONICS

Dept ACU, 15 Holland Gardens, Garston,
Watford, Herts, WD2 6JN.
Tel: 0923 894064 Fax: 0923 672102



RISC PC

	1MB SIMM	104	4MB SIMM	175
	8MB SIMM	351	16MB SIMM	586
	1MB VRAM	150	2MB VRAM	175
	486 2nd processor			199
	with RISC PC			116
	Additional case slice			116
	CD ROM Drive			233
	Ethernet interface card			116
RISC PC 2Mb 210Mb HD 14" Monitor	1467			
RISC PC 2Mb 210Mb HD 17" Monitor	1937			
RISC PC 5Mb 210Mb HD 14" Monitor	1643			
RISC PC 5Mb 210Mb HD 17" Monitor	2113			
RISC PC 9Mb 420Mb HD 14" Monitor	1996			
RISC PC 9Mb 420Mb HD 17" Monitor	2466			

HARD DISCS

A3000/3010		Scanlight Junior 256	230
60 Mb IDE	223	Scanlight Video 256 digitiser/scanner	250
120 Mb IDE	323		
A5000/500/400/300		486 25MHz	629
200 Mb IDE	317	439 with 4Mb	
330 Mb IDE	422	439 with 4Mb	719
540 Mb IDE	646		

PRINTERS

Citizen ABC 24	197	ABC 24 Colour	199
Swift 90	151	Swift 90 Colour	164
Swift 200	183	Swift 200 Colour	199
Swift 240	210	Swift 240 Colour	233
		Black Ribbon	5
		Colour Ribbon	13
Laser Direct 4	1168	Laser Direct 8	1734
Acorn JP150	245	Black Cartridge	23
Canon BJ10sx	205	Black cartridge	23
		Double refill	14
Canon BJ200	246	Canon BJC600	466
Epson Stylus 300	250	Epson Stylus 800	381
HP Deskjet 520	272	HP Deskjet 500C	305
HP Deskjet 560C	466	Double Cartridge	24
		Double refill	17
		Colour Cartridge	32

MULTIMEDIA

Eagle Mk II Multimedia Card	399	Multipodules - A3000/3010/3020/4000	44
Greyhawk greyscale digitiser	116	3 slot + HD space	114
Hawk V9 A3000	320	3 slot + user port + IDE 7 1/4 HD space	292
Scanlight Professional	690	3 slot + user port + 40meg HD	45
		Multipodules - A5000/300/400/RISC PC	45
		2 slots	351
		Starter Packs - A3000/10/20/4000	186
		Double speed CD ROM	151
		2 slots	128
		SCSI+CDFS 2.20	339
		Midi interface	433
		ScanLight 256	468
		ScanLight 256+Video 24	
		ScanLight 256+Video 24 508 line	
		Starter Packs - A5000/300/400	
		As above but slightly lower prices.	

ARCHIMEDES

A3010 Action Pk	299	with Monitor	499	RISCOS 3.1 upgrade	95
A3010 LC	399	with Monitor	599	ARM 3 with floating point coprocessor	250
A3010 Early years	399	with Monitor	599	A3000 2 Mb	60
A4000 210MB	1192	with JP150	1491	A3010 2 Mb	50
Acorn Pocket Book II 256k			269	A3010 4 Mb	155
Acorn Pocket Book II 512k			329	A3020/4000 2-4 Mb	99
				A5000 2-4 Mb	99
				A400 memory per Mb	50
				A300 4 Mb includes MEMC 1a	191

SOFTWARE

Impression Publisher	145	Dune 2	31
Impression Style	98	E-Type 2	30
Advance	116	Elite Gold Edition	38
Artworks	145	Flashback	27
Pro Artisan 2	128	FTT(Formula 2000)	23
Revelation 2	116	Guile	27
Fireworks (Wordz+Resultz)	173	Haunted House	23
Home/Club Accounts	32	Heimdall	27
Prophet	170	Hero Quest	27
Personal Accounts Version 3	46	Holed Out Compendium	23
Pipedream 4	113	Lemmings/More Lemmings for RISC-PC	26
Genesis Professional	140	Lemmings 2	28
Maggie	60	Lotus Turbo Challenge	23
Almanac 3	77	James Pond	9
Schema 2	130	James Pond 2	24
Eureka 2	116	Magic pockets	23
S-Base Personal 128	226	Magnetics	23
CC Turbo Drivers (all Types)	50	Man United	9
Compression	33	Man United Europe	9
Aggressor	13	Populus	27
Around the World in 80 days (Educ)	47	Repton 3	18
Badger Trails (Educ)	47	Premier Manager	21
Battle Chess	27	Saloon Cars	31
Black Angel	31	Sensible Soccer	22
Chocks Away Compendium	33	SpeedBall 2	24
Chopper Force	25	Splobaloids	23
Carnage Inc	24	Sim City	31
Chaos Engine	24	Sim City 2000 RISC-PC	36
Cannon Fodder	22	Simon the Sorcerer	36
Crystal Rainforest (Educ)	22	Scrapple	25
Diggers	25	Star Fighter 3000	28
		The Crystal Maze	37
		The Dungeon	33
		The Time Machine	33
		Wolfenstein 3D	27

GAMES

A function that cannot communicate with the rest of the program is of limited use. You might conceivably have a function `mode45()` which changed screen mode to mode 45, or `blob()` which generated a dingbats character, but in general you will want to pass information to and from a function.

Last issue we saw one way of getting information from a function, by using the return statement. We also saw how information is passed to the function in function arguments, which are listed with their types in the definition of the function.

How arguments are passed

I will now look in more detail at how arguments are passed to functions. In a program:

```
int square(int x)
{ x = x * x;
  return x;
}

int main()
{ int number;
  ...
  number = square(number);
}
```

the function `square()` takes an integer parameter, `x`. When it is called from `main()` the integer variable `number` is used as an argument.

Incidentally, it is conventional to use *parameter* when referring to a variable in the list in brackets in a function declaration, and *argument* for the variable in brackets when the function is called. Functions are passed arguments when they are called; they take parameters. This convention is observed above, and will be from now on.

When `number` is passed to the function, a copy of it is used, and its value assigned to the parameter `x`. `x` is therefore not the same as `number`, in fact it is a completely different variable which happens to have the same value. An implicit:

```
x = number;
```

instruction is issued by the compiler, even to the extent that if `number` is a different type of variable to `x` it will be cast to the correct type as it is passed. (The compiler may warn about this, and will generate an error if the cast cannot be done legally.)

Because an argument is copied to the parameter of a function when it is called, changing the value of the parameter will not change the original argument's value. When the value of `x` is squared within the function the value of `number` is unaffected. This is why the explicit return statement is needed.

Local variables

Another point to note is that function parameters are local to the function in which they are declared. Therefore `x` is inaccessible outside the function `square()` – in fact, it does not necessarily exist. Were we to set up a pointer to `x`, that pointer would become invalid as soon as the function was returned from. This applies whatever the scope of the pointer; if it is pointing to a variable which is local to a function, its value is invalid outside the function. The

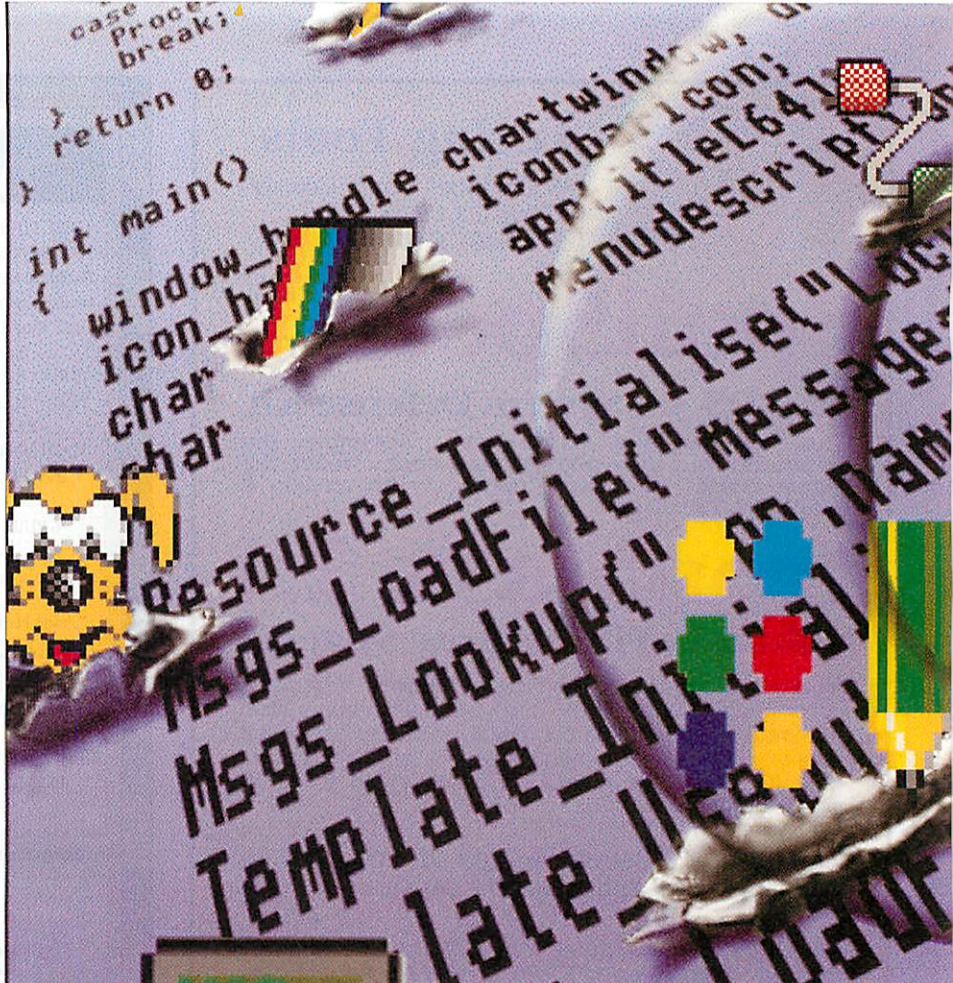

C for yo

memory to which it points may be re-allocated by the C compiler at any time outside the function.

On the whole, though, this is a good thing, as it means that the function can do exactly as it pleases with the value of `x` without having to worry about changing the value of either the original argument or any other variable called `x` that there may happen to be in the program.

Passing pointers

The fact that arguments are only copied to a function may seem a little limiting. Sometimes we might *want* the function to change the value of an argument. If there is only one value which needs changing, then it can be passed back in a return statement, as was done with the `square()` function. However, sometimes it is useful to be able to affect more than one variable.

The classic example of this is the `swap()` function, to swap the values of two variables. What we would *like* to be able to do is this:

```
swap(x,y);
```

but we can't, because whatever the function does

In the second part of the tutorial explaining how to use functions in C, David Matthewman explains how to pass arguments to and from a function.

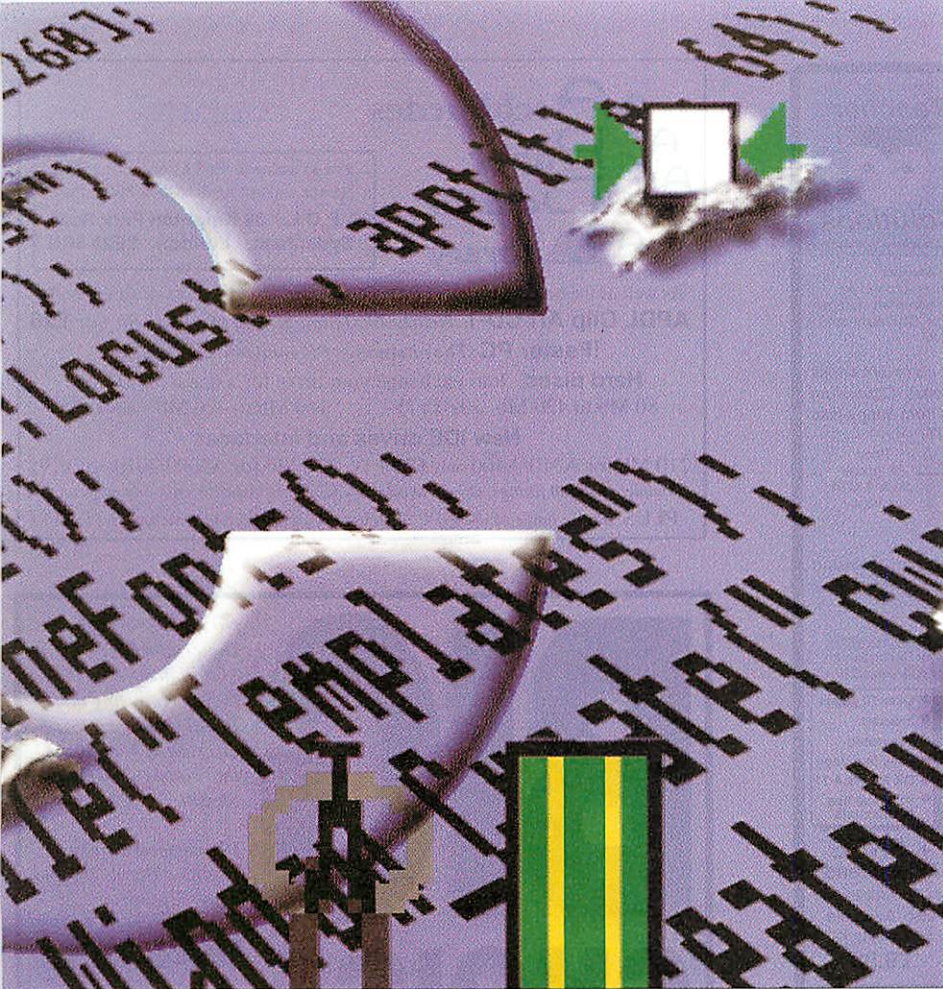

yourself

to the values of the arguments passed to it won't affect the arguments in the main program.

However, if we pass *pointers* to the variables to the functions, then we will be able to change their values. In taking a copy of the pointer, the function now knows the address of the original variable and modify it freely. The use of the * and & operators in C makes this very easy indeed:

```
void swap(int *first, int *second)
{ int temp;
  temp = *first;
  *first = *second;
  *second = temp;
}

int main()
{ int x,y;
  ...
  swap(&x, &y);
}
```

Here, the parameters of swap() have type 'pointer to int', and indeed when it is called, it is passed pointers to x and y. By using *first and *second as though they were int variables – they are *identical* to x and y in the main program in all but name – the values of x and y are swapped within the function. The function was never aware of the variables x and y by name, but it knew their addresses and therefore could change their values.

Arrays are never used as arguments to functions in C, but are always passed by using the name of the array, which is of course a pointer to the array's first element. Therefore changing the contents of an array in a function will change the array's contents in the main program; this is demonstrated by *Kate4* on the disc. Individual elements of the array can be used as arguments. Actually, arrays *can* be passed to functions as parts of structures, but that is a story for a **AU** much later issue.

Acorn C++ compiler launched

Although this column is concerned with the C programming language, it is an appropriate place to mention C's daughter language C++. This is basically an extension of C, with many features to make the programmer's life easier. Originally C++ code was converted into C code and then compiled – these days there exist many stand-alone C++ compilers.

C++ is an excellent language for programming a windows environment. For this reason, it has been an eagerly-awaited addition to the programming languages on the Archimedes.

Actually, there has been a C++ interpreter available for over a year. GCC, the C++ compiler from the Free Software Foundation, also has the advantage of not costing anything. Unfortunately it gobbles memory – in the days before the Risc PC it was impractical to run it without *Virtual*, a virtual memory program – and is not the easiest of programming suites to set up.

Around the start of the year, Beebug released *EasyC++*, which compiles C++ code directly into ARM code. *EasyC++* has been well-received and, at £99 + VAT, represents a reasonably-priced introduction to C++ on the Archimedes.

Now Acorn has entered the fray, with a £212.72 + VAT C/C++ compiler, replacing its *Desktop C* compiler. Surprisingly, given the existence of *Easy C++*, Acorn has decided on a front-end interpreter for C++ which turns the code into C before compiling it. This is based on Cfront version 3.0, and has support for templates but not – unlike *EasyC++* – exceptions. The C

compiler has full support for ARM600 and ARM700 processors, with options to write full 32-bit code, and an ARM assembler is also provided.

Perhaps the most significant part of the release is the provision of a resource editor and *Toolbox*. Templates for applications will now be stored in a 'resource' file – the relationship of this to an &FEC templates file is unclear – which contains windows, menus, the icon bar icon and so on. Objects created from this file can be manipulated by *Toolbox*, which is in Acorn's words 'a set of relocatable modules which provide an abstraction on top of the RISC OS window manager for writing Desktop applications.' *Toolbox* will be available for use from other programming environments, and is designed to replace and improve upon *RISC_OSlib*. As Acorn says: '*Toolbox* does not provide a flex memory management system, *SWI veneers*, or *TxtEdit*. However, none of these are critical omissions since memory can be managed efficiently within applications using malloc, the need for *SWI veneers* is largely obviated by the toolbox, and no major applications to date have used *TxtEdit*.'

It is clear from this that Acorn's C/C++ compiler will stand or fall on the quality of the *Toolbox*. If the claims made for it are borne out, it should be a welcome development tool for anyone designing a RISC OS Desktop application. However, anyone who has tried to use the bugged and badly-designed *RISC_OSlib* supplied with *Desktop C* will want to see *Toolbox* in action before committing themselves.

There will be a 10 per cent discount for clan members.

REPORTER+ £44.99

With Reporter+ you can:

- *Deal with 40 pupils
- *Use provided comment banks
- *Write own comment banks
- *Use Copy facility
- *Cut time spent on reports
- *Sort & produce class lists
- *Spread reports through year
- *Work out pupils' ages

To use Reporter+ you need Any word processor/DTP program that accepts Edit files, (practically all of them).

More complex report and certificate formats can be created using Draw with any Impression application.

Teacher



Solutions

For teachers by teachers

Site licences
Primary schools free.
One Secondary dept free
Whole Secondary school
£89.99

Price of goods back if at all unhappy

A non-Desktop Arc utility for pupil reports, class lists etc. Up to 22 comment banks of 143 statements & 22 user defined fields possible. National Curriculum statements available as comment banks at a minimal cost. Runs from floppy disc & suitable for all ARC type machines. Easy to use even by the "IT challenged".

DRAW TASKS £44.99

Single copies (without copying rights) for home use cost £16.99
Suitable for Junior or Secondary pupil use & staff training

A step by step guide to Draw & the Desktop basics written by a teacher. Unlimited printing within purchasing institution. 72 A4 photocopyable masters+original files for ease+flexibility. Examples can be lifted off disc for extra activities.

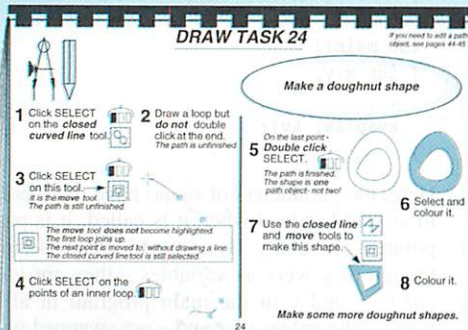

Versions available for Riscos 2 or 3 dual order=£65

- * Over 70 pages
- * Indexed
- * Illustrated
- * Easy language
- * OK for yrs 4-11
- * Practical tips for teachers

+ FREE Draw Ideas
21 worksheets on disc. Available separately for £9.99

Teacher Solutions (Tel 0457 85 5774)
8 HADFIELD STREET, GLOSSOP,
DERBYSHIRE SK13 8JL

Cheques payable to Teacher Solutions for full amounts shown +£2.00 P & P per UK order. (Overseas at cost, max order weight=700g)

Archimedes Public Domain Library

Incorporating
VINTAGE M

For a catalogue send £1 or four 1st class stamps and ask for 1.6Mb or 800K discs.
A.P.D.L., 39 Knighton Park Road,
Sydenham, London SE26 5RN

As well as the best collection of P.D., Shareware, and low cost software we offer
APDL Clip Art CD-1 Nearly 7000 files, 500Mb of clip art for just **£28**
!Faster PC The alternative PC emulator - only **£20**
Hard discs - Part exchange your drive for a massive 420 Mb
80 Mb to 420 Mb only £175 :-: 160 Mb to 420 Mb only £155
New IDE drives and interfaces
210 Mb for A310/A400 only £220 :-: 120 Mb for A3000/3010 only £195
(Complete with all fittings. Others available. All prices inclusive - nothing more to pay)
PLUS a huge range of cheap PC Shareware for use with a PC emulator or PC card.

BIG CHOICE

No PD Library offers a choice of PD as wide as Skyfall does. So don't bother collecting other PD libraries catalogue discs. Send for the one that counts. And choose Skyfall.

Please send £1 for the Preprinted Catalogue and demo disc to:

SKYFALL PD

PO Box 2220
Birmingham
B43 5RZ



Programs available for all ages and abilities:

- For school and home use •
 - PC and Acorn formats •
- Send for our free catalogue.

4Mation
Publishers of
quality educational
software since
1983.

4Mation Educational Resources
14 Castle Park Road
Barnstaple
Devon
EX32 8PA
EX32 8PA
(01271) 25353

SOFT SECTOR Tel: 0962 863225

UNBRANDED DISKS: SONY, VERBATIM, KAO, DYSAN etc.
(Subject to availability). 100% Certified Guaranteed Error Free
Packs of 10 supplied with FREE Library case

3.5" DSDD	£4.90	5.25" DSDD	£3.75
3.5" DSHD	£6.60	5.25" DSHD	£5.80

Labels included Envelopes & labels included
Enquiries welcome for bulk orders

LOCKABLE DISK BOXES

50 Cap 5.25"	£5.95 each
100 Cap 5.25"	£7.25 each
40 Cap 3.5"	£5.25 each
100 Cap 3.5"	£6.75 each
200 Cap 3.5", File Drawer	£11.99 each

ACCESSORIES

Library Cases 5.25"	£1.15 each
Library Cases 3.5"	99p
Mouse Mats Red, Blue, Grey	£2.30 each
Disk Labels 3.5"	£1.20 per 100
Disk Labels 5.25"	£1.60 per 100
Disk Envelopes 5.25"	£3.40 per 100
Disk Drive Locks 3.5"/5.25"	£11.50

Printer Ribbons Toner cartridges - Original and Compatible - Ring for Prices
ALL PRICES INCLUDE VAT - NO EXTRA CHARGE FOR POSTAGE & PACKING
GOVERNMENT AND EDUCATIONAL ENQUIRIES WELCOME

SOFT SECTOR 58 Andover Road, Winchester, Hants SO22 6AG

CARLTON SOFTWARE

Acorn & Epson Appr. Dealer

New Year Give Away !!!!

Pocket Book II - £214	A Link - £39.99	P.C. Link - £55.
Pkt.Bk OPL Programming Manual - £10	Ask for Pkt.Bk. Software	
Animator - £49	Photodesk - £149	EasyFont 3 - £24.99

Fire Workz + Free Home Accounts - £79

Computers : ask for a competitive quote

Our Risc PC includes 1Yr. onsite maintenance

£90 off any other order or 0% finance & free software apprx. value £90

Special upgrades. LOW LOW prices Excellent Service Phone us.



*Credit Cards -
COD/ind UK



Open M-F 4.30pm - 9.30pm Sat 9-5

Carlton Software, Felmersham Rd,
Carlton Bedford. MK43 7NA
Add VAT, Add Carr. £8h/w, £4 S/w

Tel/Fax 01234 721448

Items subject to avail. E&OE



TOP QUALITY P.D. WITH LOW PRICES
AND A FAST AND FRIENDLY SERVICE
WHAT MORE COULD YOU ASK FOR?

Our *NEW* demo disc/catalogue for just £1

EXCELLENT PACK OFFERS

At only £3.50, each pack has three discs with the best fully archived selected software.

- Games Pack 1 • Games Pack 2 • *NEW* Games Pack 3
- Draw Clipart Pack 1 • *NEW* Draw Clipart Pack 2
- Sound Sample Pack 1 • *NEW* Sound Sample Pack 2
- Utils Pack 1 • *NEW* Utils Pack 2 • Educational Pack

Buy any two packs and get our demo disc free.
Buy any four packs and get a free mystery disc.

Exclusive to Five Star as budgetware the FULL version of the game DINOSAW at only £3.75



Five Star Marketing, 4 Shepherds Walk
Bushey, Herts. WD2 1LZ.



Questions & answers

Touch-typing programs, problems with SLIPdial, memory upgrade limits and trouble at t'A-link.

Q I am teaching myself to touch-type. At the moment, I am using a standard book of typing exercises and typing the text into *Edit*.

Do you know of any programs available for the Archimedes which would automate this process? What I want is a program which will take me through the standard typing exercises and give me an idea of my speed and accuracy of typing.

David Winterton
Carlisle

A There are a number of such programs around. Many are public domain and will be stocked by PD libraries; they may also be downloaded from Hensa. Examples of these are *Typist* and *TypeTute*. A commercial program which I would recommend – it runs in the desktop and provides statistics on all the basic exercises – is *TypeTutor* from the ARM Club (0171-624 9918). This costs £10 and is complete with diagrams explaining which keys your fingers should be on during touch-typing.

Q I have recently got hold of a copy of the *Internet Starter Kit* which contains a number of programs to help me connect to Demon. Sadly, one of them is giving me problems; *SLIPdial*. I can make this program dial up my nearest POP, but when it has connected, it seems to load up *TCPIP* for all of two seconds before quitting it again and loading *TTFN*, the newsreader

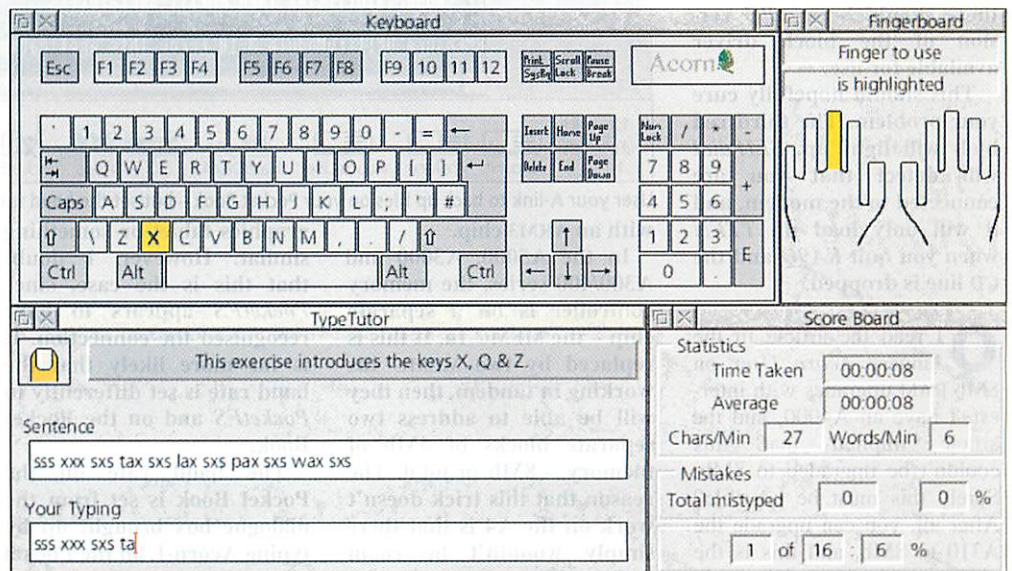

Typing Tutor by the ARM Club – learn to touch-type in the Desktop.

that comes with it.

I don't think that it is meant to do this. As you have answered queries on the Internet before, I wonder if you could help me. I have an A5000 with RISC OS 3.1 and 4Mb of memory, which is connected to a US Robotics Sportster 14400 modem.

Geoffrey Banks
Irlam

A It is 99 per cent certain that the problem is caused because *SLIPdial* is not registering the CD (Carrier Detect) signal from the modem.

There are three little red blobs which should light up in the bottom right hand corner of the status window of *SLIPdial*. If only two (or less) of these are lit, then *SLIPdial* does not realise that a successful connection has been

made and acts as you have described.

Since you have an A5000, it is more than likely that you will have been sold a PC-standard serial cable with your modem. Although such a cable will give you no problems, as it would on earlier machines, it is wired differently from a cable designed exclusively for an Archimedes.

Now, *SLIPdial* and *KA9Q* both communicate with the serial port on the Archimedes via the *Serial block drivers*. These are written by Hugo Fiennes and can be found within the *!Serial* directory in the starter kit. They are designed to allow communications software to access a variety of different serial interfaces – including The Serial Port's own dual serial card – using a standard set of

commands. Normally their operation is automatic, and they can be ignored.

However, the standard driver for which *KA9Q* is by default configured is the *Internal* driver. This driver is the wrong one to use for a modem with a PC cable; the *InternalPC* driver should be used instead. *KA9Q* will work happily with the wrong driver, since the differences between the two have no bearing upon its operation. However, *SLIPdial* also uses the block drivers, and in this case the wrong block driver causes it not to notice the CD signal from the modem.

SLIPdial asks which block driver to use when it is first run – one solution is to delete the *!SLIPdial.Scripts.demon-config* file, thus causing *SLIPdial* to run its configuration sequence again.

Problems solved

However, it is in practice just as easy to edit the above file to replace Internal with InternalPC in the first line.

For completeness, you should also change a line in the *!TCPUser.Config* file which also refers to the block drivers. The line is about 16 lines into the file, and will read something like:

```
attach asy Internal 0 slip
ax0 2048 576 0
```

The Internal in this line should be changed to InternalPC.

Note that even if you are using one of the other block drivers to drive the modem through an expansion port, there should be a ...PC version of the block driver available for use.

This should hopefully cure your problem. The third red blob will light up, *SLIPdial* will detect that you are connected to the modem, and it will only load up *TTFN* when you quit *KA9Q* and the CD line is dropped.

Q I read the article in the January *Acorn User* on 8Mb RAM upgrades with interest. I have an A4000, and the article implied that this couldn't be upgraded to 8Mb. Surely this must be possible? After all, you can upgrade the A310 to 8Mb, and this is the oldest Archimedes of them all. You can even upgrade an A3000, which is a low end machine. What is so different about my machine?

Colin Smith
Basingstoke

A The A4000 – and the A3010 and A3020 – is based around the ARM250 chip. This is a radical new design of ARM chip with the processor, memory controller and video controller all on one chip. While this produces a very compact design of chip, it does mean that none of these can be upgraded, as the entire chip would need to be replaced.

Sadly, the memory limit of the memory controller is 4Mb, so even though you could in theory fit more memory in an A4000 the processor would be unable to address it. Similarly, an A4000 cannot be upgraded

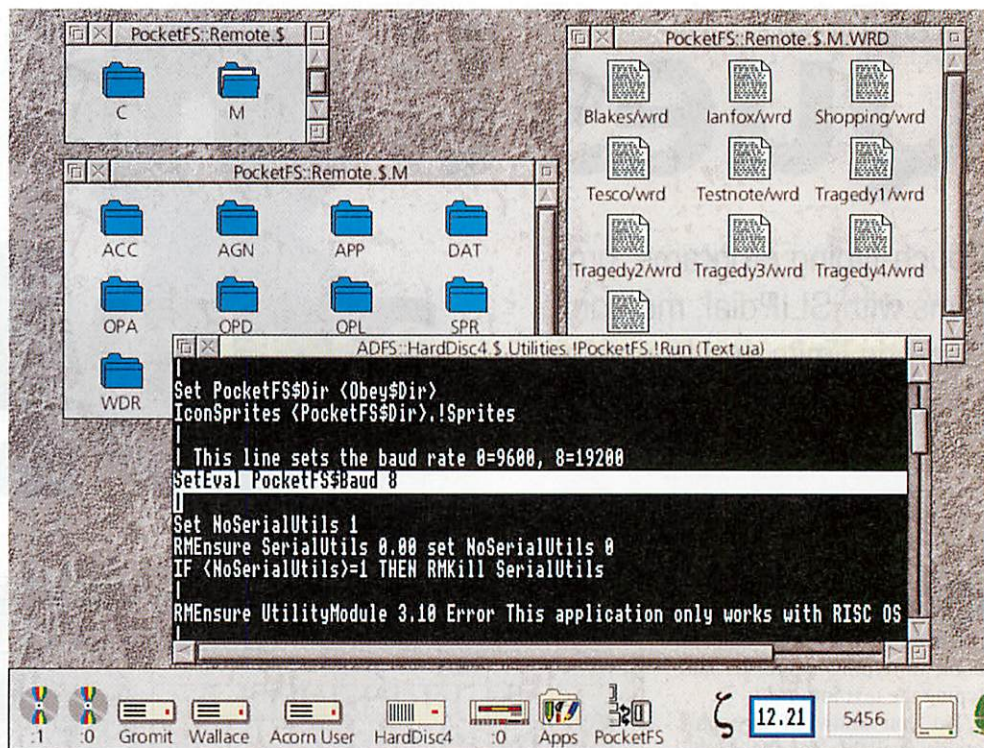

User your A-link to back up files on your Pocket Book – but set the baud rate correctly first.

with an ARM3 chip.

In the A5000, A3000 and A300/400 series, the memory controller is on a separate chip – the MEMC 1a. If this is replaced by two MEMC 1as working in tandem, then they will be able to address two separate blocks of 4Mb of memory – 8Mb in total. The reason that this trick doesn't work on the A4 is that there simply wouldn't be room inside the case to fit the upgrade.

Q Please can you help me with a problem that I am having with my portable computer. I am trying to use my A-link with *PocketFS 2* to transfer files between my Pocket Book II and my Archimedes. Although the connection appears to have been made correctly – the *PocketFS* icon changes from red to brown – I can't open a directory showing the contents on the Pocket Book on my Desktop. It keeps telling me that it is getting no response.

Can you tell me what I am doing wrong?

Jimmy Montrose
Newport

A The first thing to check is that nothing is interfering with the operation of the serial port – comms software, serial port mouse,

graphics tablet or something similar. However, I doubt that this is the case, since *PocketFS* appears to have recognised the connection. It is far more likely that the baud rate is set differently in *PocketFS* and on the Pocket Book.

The baud rate on the Pocket Book is set from the dialogue box brought up by typing Acorn-L on the Pocket Book desktop, and can either be 9600 or 19200 baud. If you are connecting to an older machine than an A5000 it is probably advisable to use 9600, as its serial port can be unreliable above this speed. The baud rate in *PocketFS* is written into the *!Run* file and cannot be changed from the icon bar. Load the *!Run* file into *Edit* and change the baud rate either to 0 (for 9600) or to 8 (for 19200). Either way it must be the same as for the Pocket Book.

Tip of the month: back your Pocket Book up onto a DOS-formatted floppy disc (or several). Do this by opening a directory-view window by clicking on the *PocketFS* icon with Adjust rather than select. This will show the files on the Pocket Book by their proper names using DOS-style three letter extensions. These can be copied to a

DOS-format disc and will have their full names preserved, even those with twelve characters which would otherwise be truncated by RISC OS. Alternatively, get the excellent *LongFiles* PD program by Jason Tribbeck which allows filenames of up to 55 characters in RISC OS.

Help for beginners

Starting next month will be our Absolute Beginners series for new Archimedes owners just starting to learn their way around their machine. It will cover areas more basic than are usually addressed in *Acorn User*, and will therefore be very welcome to those who are constantly baffled by the more technical sections of the magazine.

Although we have a clear idea about what the first few articles will cover, we welcome suggestions from readers about topics that you would like us to explain.

Absolute Beginners will in no way replace Questions and Answers, which will continue to answer technical queries, give general advice and sort out any irritating problems you may have, so keep the questions flooding in for these pages as AU well.

ACORN USER guide to local dealers

WEST YORKSHIRE

Davyn Computer Services

For the best service in Yorkshire (we think) CALL US!
For A3000, A4000, Risc PC, A4 Portable & Acorn Pocket Book. Visit our showroom
Open 9.30 to 5.30 Mon, Tues, Weds, Sat
9.30 to 7.30 Thurs & Fri

Tel (0924) 254800

Printer & Ribbon Sales
Expert Advice & After Sales Service
Service & Repairs to All Equipment
Full Range of Acorn Hardware & Software
(We operate the Acorn Finance Schemes)

Full Range of Educational Software in stock & on DEMO

The 'Workshop', off Princess St, Sandal, Wakefield, West Yorks, WF1 5NY

Acorn Cannon CITIZEN Calligraphy



BIRMINGHAM

DACO SYSTEMS

459-463 Warwick Road, Tyseley,
Birmingham B11 2JP

DACO'S
COMMITMENT:
Competitive without
compromise

**The Midlands
Largest Local
Dealer**

- Special Needs • Business •
- Education • Home Use •
- Repairs • Networking •

Tel: 021-706 8933



DERBYSHIRE

Acorn's full range at bargain prices
Risc PC's call us for details of our SPECIAL offers

Sound Practical Advice - Demonstrations Daytime, Evenings and Weekends

Memory Upgrades - Hard Disc Drives - Printers - Scanners - Software

Acorn Assist Scheme for Academic's - Teacher's - Student's - Mail Order Available

0% and Low Cost Finance Terms Available (Subject to Status)

Telephone Hot Line Technical Support - Spares and Repairs - Home Tuition

High Definition Colour Scanning and Printing Service Available



Telephone and FAX
01 332 690691

8 Old Gate Avenue - Weston on Trent - Derby - DE72 2BZ

CUMBRIA

CSS Computer Centre
Acorn Education Centre
Acorn Unix Centre



Showroom open 9-5.30

Six days a week

Training. Free fitting add ons

Repairs and maintenance



NEW RISC PC 600 IN STOCK

CUMBRIA SOFTWARE SYSTEMS LTD
Unit 3A, Townfoot Ind. Est., BRAMPTON
CUMBRIA CA9 1SW

☎ 06977 3779

WALES

UNIQUEway Acorn
Replay



**SOUTH WALES' ONLY
DEDICATED ACORN DEALER**



Multimedia is our speciality.

Risc PC and CD-ROM systems always on display.

Full range of games, business and home software
to try before you buy.



Technical Support - Home Demonstrations - Repairs - Hire

Low cost finance available on all systems

42 Crwys Road, Cardiff, CF2 4NN

Tel: 01222-644611 Fax: 01222-644622

PLEASE NOTE NEW PHONE NUMBER FROM 1st AUGUST 1994

ESSEX



AT LAST!

A File Server which INTEGRATES your computers

The DATATHORN SUPER SERVER

- Integrates Ethernets of Acorn, Apple and PCs
- Enhances fast RISC based computers (eg RiscPC)
- is EASY to manage and INDUSTRY-STANDARD
- can run DIFFERENT NOS (eg NT, Novell)
- can support upwards of 75 CLIENTS
- is the most COST-EFFECTIVE server for 20 users
- is the first PowerPC/PCI based server offered to education
- has built-in CD-ROM
- is guaranteed by MOTOROLA for FIVE YEARS

Datathorn is an i3 preferred dealer and Acorn
Education Dealer.

Contact John Hart or Vince Hagedorn now
on (0181) 502 4221

DATATHORN
Systems Ltd

The Seedbed Centre, Langston Rd, Loughton ESSEX. IG10 3TQ
Fax (0181) 502 6660 Email: sales@dlhorn.demon.co.uk

SOFTWARE SHOWCASE

DTP

TableMate 2



TableMate 1 & 1.1:

- Praised in reviews
- Bundled with Impression Style

TableMate 2:

- Many new features
- Available NOW.

New features include:

- Colour handling
- Word wrapping within columns
- Draw files inside cells
- Full price £32-50 inc. P&P (No Vat)
- Upgrade prices for Impression Style/Publisher & TableMate users
- Phone or send an SAAE for details
Dalriada, 145 Albion St, Kenilworth Warks. CV8 2FY. ☎ (0926) 53901

EDUCATION

Software for Serious Science & Technology

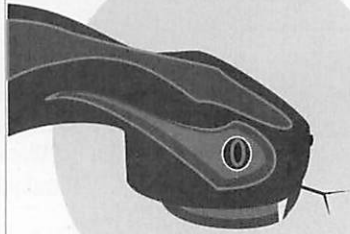

WRITE NOW FOR OUR FREE DEMONSTRATION DISC FOR SCHOOLS

SSERC SOFT

SSERC (AU), 24 Bernard Terrace, Edinburg EH8 9NX
Tel. 0131 668 4421 or Fax. 0131 667 9344

UTILITIES

BLINDS

"At last a truly professional Pinboard!"
Blinds is a new, easy to use and sophisticated 'Pinboard' type application which will make your life a whole lot more effortlessly when using your computer.

- Have blinds which snap open and close at the click of a mouse, therefore taking up **no** valuable desktop space.
- Give your icons long meaningful names at last!
- Change the icon displayed by choosing from over one thousand sprites we have provided.
- Set windows to open automatically whenever your favourite application is loaded. You'll never have to look for that elusive file again!
- Make a blind which will attach itself to the side of your application, it will then follow your favourite application's window around the desktop just like it was made for it!

RISC USER review - "It went straight onto my icon bar!"
Blinds costs only £19.95 fully inclusive of postage, etc. No V.A.T. Blinds requires RISC OS 3.10 or better. A demonstration disc is available free of charge on receipt of a A5 size SAAE. You'll find Blinds is available from all good Acorn software dealers or direct from:
Quantum Software at 35 Pinewood Park, Livingston, EH54 8NN, Scotland. Tel/Fax : 01506 - 411162

LET ME ASK YOU A QUESTION....

Is there a software company advertising in this magazine that will sell you no less than FIVE games and a program to help you write adventure games for only £19.99?

YES: SOFT ROCK SOFTWARE WILL

For only £19.99 including postage you can have: Switch, Floopy, Escape from Exeria, Guardians of the Labyrinth, Drop Rock AND Trellis (the Adventure Interpreter).

AND IT'S A FREEPOST ADDRESS, TOO!

SOFT ROCK SOFTWARE, FREEPOST (BS 7978)
WESTBURY-ON-TRYM, BRISTOL, BS10 7BR
(please state where you saw this advert)

Risc PC owners please write for details of software for your machine.

SPECIAL NEEDS

J Computing

Your Southwestern Acorn Dealer

Repairs
Special Needs
Educational Dealer

NOW OPEN IN STROUD

57 Westbury Hill
Westbury-on-Trym
Bristol BS9 3AD
Tel: (0272) 624553
Fax: (0272) 490901

Latest Hardware and Software

MUSIC

PROGRAMS FOR MUSIC PUPILS

THEORY OF MUSIC Questions and Exercises £16
(Covers all elements of Theory from Grade 2 to Grade 5+)

LEVEL 1 THEORY OF MUSIC - tutorial £16
(Usable by a beginner in music - full preparation for Grade 1 Theory, with further help and exercises up to Grade 3)

PLAY WHAT I PLAY (Aural training game) £13.50
(The above programs are still available for BBC B and Master; please inquire)

ESSENTIAL THEORY OF MUSIC for PC £23
(Beginner to Grade 5 - rolling practice in elements of Theory, with full Help system. Recommended if you have a PC card)

from **TED KIRK (AU) 0744 818761**
33 Humber Crescent, ST. HELENS WA9 4HD

SOFTWARE/HARDWARE

The speedy solution

FLYPRINT

Adverts / Raffles / Memos & Tickets
with serial numbers, in any quantity.

Any 32 bit Acorn Any Epson Compatible printer
Only £39.97 inc

KEYBOARD EMULATOR

On Screen Keyboard
Full features including entry into filer & menu icons
£12.00 NEW
Ideal for Special Needs

Textile Transfer Paper

Print it - Iron it - Wear it
Full COLOUR
Dot matrix-ink Jet-Laser-Thermal-Copiers
4 Sheets **£4** 30 Sheets **£44**

Dead Cert,

Certificate and Award Maker
Exotic Borders - Auto Resizing
Import Clip Art - Full Colour



Dixon & Dixon

35 Rokeby Drive, Kenton
Newcastle -U-Tyne, NE3 4JY

0191 2853042 North. East Acorn Dealer

Prices inc VAT and postage UK mainland

VIRUS? ...not with SMARTKILL

SmartKill is the only general purpose virus killer on the Acorn market capable of removing both known and unknown viruses, and therefore the only package to provide true protection of your computer system through unique prevention and removal routines.



Single user copy, **only £15**
(Introductory offer)

Site Licence, **just £45**
Cheques or Postal Orders only, please

Telephone: 01252 621004
42327@6DemonCoUK

MG RESEARCH

46 Corringway, Church Crookham, Fleet, Hants, GU13 0AW

STATISTICS

Statistics with Graphics

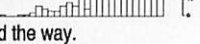

1st, 1st Jr, and 1st L lead the way.
Our ESTABLISHED products cover levels from school (GCSE) to advanced research. Upgrade paths, Site licences and Loan copies are all available

1st Serious Statistical Software, Lynwood, Benty Heath Lane, Willaston, South Wirral L64 1SD Tel 051 327 4268

MULTIMEDIA

The Acorn RISC-OS CD-ROM User Group

CHOOSE FROM OVER 500 CD-ROM's

Including PDCD1 (Issue 2)
Special Price to Members
Annual Membership £12.50
SAVE ££££££££££££'s

For Trial News/Catalogue Disk - Send 2 First Class Stamps
CD Circle PO Box 332 Bristol B99 7XL

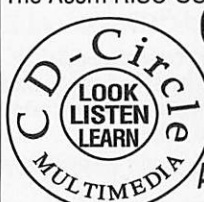

Acorn

Customer hotline

Essential information for all Acorn users, compiled by Dave Walker of Acorn Customer Services exclusively for Acorn User.

Questions and Answers

Q Where's my nearest Acorn dealer?

A As the list of Acorn dealers is constantly changing, there is no fully comprehensive up-to-date copy on paper, although paper copy detailing the majority of dealers is available. Customer Services maintains an on-line database of dealers and their addresses, from which we can generate a comma-separated variable (CSV) list suitable for loading into most other databases. This list is available via anonymous ftp as [ftp.acorn.co.uk:/pub/documents/dealers/uk](ftp://ftp.acorn.co.uk/pub/documents/dealers/uk), and by download from the 'Acorn support' areas of Arcade (tel: +44 181 654 2212) and Digital Databank (tel: +44 1707 329306) BBSs. In addition, a plain text list of overseas dealers and distributors is available as [ftp.acorn.co.uk:/pub/documents/international](ftp://ftp.acorn.co.uk/pub/documents/international). If you don't have a modem, you can always ask us!

MODE in BASIC: The next generation

The way in which modes are specified on the Risc PC has been changed in order to allow the new extended range of modes to be accessed; modes now have associated strings, instead of just numbers.

A typical BASIC command to change mode would now be:

```
MODE "X800 Y600 C32K EX1 EY1 F50"
```

which can be broken down into:

X800: 800 pixels horizontally
Y600: 600 pixels vertically

This is a fairly common resolution; alternative choices are determined by the Monitor Definition File (MDF).

C32K: 32016 colours. Other common options, depending on the resolution of the mode and VIDC bandwidth, are:
C256: 256 colours
G256: 256 grey levels
C16M: 16392192 colours

This last level is actually better than the average human eye can resolve (the eye has been shown to be able to chromatically resolve roughly 15.4 million hues).

EX1 EY1: Horizontal and vertical 'eigenvalues' of 1. These eigenvalues relate to the method of mapping of OS units onto pixels. If EX1 is increased, the most obvious effect is that the size of windows, text and icons decreases in the X direction; this effect can be used to produce a Desktop with an apparently larger work area. However, if the eigenvalue is set to a high value, parts of the display may 'go missing' owing to the mapping producing pixel overlap.

F50: 50Hz frame rate.

This string representation of screen modes can be accessed from the 'Mode' entry on the icon bar menu belonging to the standard screen control icon.

Many 'old' style screen mode numbers can still be used; modes 0, 1, 8, 9, 11, 12, 13, 14, 15, 25, 26, 27, 28, 41, 42, 43, 44, 45, 46, 47, 48 and 49 are explicitly defined, and modes close to the resolution of other 'old' modes may be defined in MDFs.

Somewhere in time

The first 32-bit Acorn machine to use a rechargeable battery to power the real-time clock and CMOS RAM was the A3000. The batteries used are considered to have a lifetime of five years; this means that the batteries on many A3000s are reaching the end of their life span. If your machine appears to re-configure itself on power-up, or the real-time clock shows a decidedly unreal time, you need to contact your dealer for a battery replacement.

The CMOS uses two bits to determine the relationship between the current year and the next leap year, so you may also find your reset clock defaulting to 1991 by virtue of a leap year having occurred since RISC OS 3.1 was released; a reset to

1995 using *Alarm* will fix matters, and your clock will still roll over properly to 1996 at the end of this year.

World Wide What?

Probably the most talked-about method of accessing Internet-based resources over the last couple of years is World Wide Web, particularly when connected with a new generation of graphical hypertext-based client programs such as *xmosaic*. Web documents are served using the HyperText Transfer Protocol (http), and addresses of Web documents are specified using Uniform Resource Locators (URLs). A URL has the syntax:

```
<protocol>://<site>/{|<filename.html> }
```

Currently there are two Freeware browsers available for RISC OS, and several companies are working on commercial packages which will also include browsers.

During November Acorn opened www.acorn.co.uk, our own server containing a range of product and technical information, so we could determine if users would find such a service valuable. 17638 accesses and plenty of constructive e-mail convinced us we were doing the right thing!

Currently www.acorn is being developed in readiness for a full opening and will be open later in the year. Some concern has been expressed over the www.acorn alias having been removed from our DNS; this was done because attempted logins to the blocked service were not generating timeouts correctly, resulting in hung processes at the client end. **AU**

Acorn Customer Services
Acorn Computers Ltd
Acorn House, Vision Park,
Histon, Cambridge CB4 4AE
E-mail: customer.services@acorn.co.uk

Watford Electronics

Jessa Group of Companies – Established 1972

Mail Order & Showroom: Jessa House, 1 Finway, Dallow Road, Luton LU1 1TR
Tel: 01582 487777 Fax: 01582 488588

Showroom Only: Jessa House, 250 Lower High Street, Watford WD1 2AN
Tel: 01923 237774 Fax: 01923 233642



RiscPC 600 Computer Systems

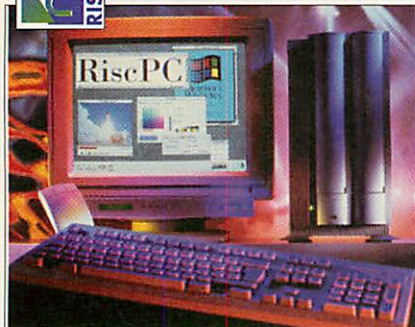

The RiscPC from Acorn offers all the traditional strengths of RISC processing, and a great deal more, at a remarkably affordable price. Based on a 30MHz ARM610 processor, the RiscPC simply leaves the competition standing.

It is the world's most cost-effective 32-bit RISC computer. The graphics on the RiscPC are astounding - 24-bit colour (2Mb VRAM required) at resolutions up to 1600 x 1200 pixels. The memory capacity starts at 2Mb and can be expanded to a massive 256Mb. A special slot for a 2nd processor is provided, allowing you to add an additional ARM processor or any other processor, so allowing easy low cost access to DOS and Windows based applications.

The standard sound system offers 8 channel stereo sound, which can be upgraded with the optional 16-bit sound card. Networking options include Econet and industry standard Ethemet. There is also a choice of either 14" or 17" monitors.

Specification:-

- ARM610CPU running at 30MHz
- 2Mb, 4Mb or 8Mb RAM expandable to 256Mb
- 210Mb or 420Mb IDE Hard Disc Drive
- up to 2Mb VRAM for high resolution graphics
- 8 channel stereo sound
- 24-bit colour graphics
- 2nd processor slot
- RISC OS 3.5 operating system in ROM
- 2 or 4 32-bit expansion slots (expandable to 8 slots)
- 3.5" 1.6Mb high density floppy disc drive
- 5.25" drive bay for floppy drive or CD ROM drive
- 14" EPA compliant SVGA monitor (AKF60)
- 12 months On-site warranty

RiscPC Upgrade Options

Memory Upgrade Options

ARA0340/U	upgrade from 2Mb to 4Mb RAM	£59.00
ARA0350/U	upgrade from 4Mb to 8Mb RAM	£109.00
ARA0360/U	upgrade from 8Mb to 16Mb RAM	£249.00
ARA0410/U	upgrade from 1Mb to 2Mb VRAM	£79.00

Hard Disk Upgrade Options

ADA1520/U	upgrade from 210Mb to 420Mb IDE hard drive	£119.00
ADA1530/U	upgrade from 210Mb to 540Mb IDE hard drive	£179.00
ADA2320/U	upgrade from 210Mb to 1.0Gb SCSI hard drive	£499.00

Monitor Options

MKA1640/U	upgrade from 14" to 15" Aries 6000 monitor	£99.00
MKA1620/U	upgrade from 14" to 17" Aries 7560 monitor	£299.00
MKA1670/U	upgrade from 14" to 17" Acorn AKF85 monitor	£379.00

Miscellaneous Options

AEA1650/U	upgrade to 486SX 33MHz PC Card	£99.00
AEA1890/U	upgrade to 16-bit Sound Card	£55.00
APA0250/U	upgrade to Dual speed CD ROM drive	£179.00

RiscPC 2M HD210

- 2Mb RAM expandable to 256Mb
- 210Mb IDE Hard Disk Drive
- 2 expansion slots
- 14" EPA compliant SVGA monitor
- 1Mb VRAM for enhanced graphics

£1219

RiscPC 5M HD210

- 4Mb RAM expandable to 256Mb
- 210Mb IDE Hard Disk Drive
- 2Mb VRAM for enhanced graphics
- 2 expansion slots
- 14" EPA compliant SVGA monitor

£1379

RiscPC 9M HD420

- 8Mb RAM expandable to 256Mb
- 420Mb IDE Hard Disk Drive
- 2Mb VRAM for enhanced graphics
- 4 expansion slots
- 14" EPA compliant SVGA monitor

£1659

Free VRAM upgrades with the above systems

Learn & Play System

- RiscPC 600 2M HD210 Computer
- 14" SVGA monitor
- Software Bundle – worth £250

Includes: 10/10 English, French, Spelling, 10/10 Junior Essentials & Maths - Number, Virtual Golf, Haunted House, Break 147, E-Type 2 and The Dungeon.

Special Offer Price **£1189**

Acorn Pocket Book



The truly personal computer. With built-in word processor, spreadsheet, database, spell checker and scientific calculator, it provides all the basic tools for recording ideas, notes and data.

Pocket Book 256K Computer	£165
Pocket Book II 256K Computer	£219
Pocket Book II 512K Computer	£269

Pocket Book Accessories

● A-Link	£40.00	● Plotter Class Pk	£250.00
● Parallel Link	£25.00	● 128K RAM Disc	£49.00
● PC Link	£59.00	● 256K Flash Disc	£59.00
● Mac Link	£65.00	● 512K Flash Disc	£85.00
● Schedule	£16.00	● OPL Editor	£59.00
● Schedule Class Pk	£160.00	● Mains Adaptor	£12.00
● Plotter	£25.00		

0% Finance

available on all basic RiscPC systems, A4000 systems and A4 Notebooks. Call 01582 745555 for more details.

Multimedia Systems

Enter the world of multimedia with the RiscPC CDI system. Gain access to the massive amounts of data on CD ROM, study the masses of text, pictures and sound all interacting with each other. The ideal tool for educational use.

CDI System Specification:

- Dual speed CD ROM drive
- Aries Stereo Speakers
- 14" Multiscan monitor
- Hutchinson Encyclopedia CD
- Sherlock Holmes CD
- Really Useful v2 CD
- Acorn Video Clip CD

CDIA System Specification:

- Dual speed CD ROM drive
- Audio Mixer
- Aries Stereo Speakers
- Hutchinson Encyclopedia CD
- Sherlock Holmes CD
- Really Useful v2 CD
- Acorn Video Clip CD
- Pro Artisan v2 CD

● 5M CDI System	£1579	● 5M CDIA System	£1629
● 9M CDI System	£1849	● 9M CDIA System	£1899

Publishing Systems

One of the main uses of the Acorn RiscPC is Desktop Publishing. Utilising its immense processing power and high quality graphics, you will be able to produce professional quality documents without having to spend a lot of money. The system comes supplied with the highly acclaimed Artworks graphics package and the powerful Impression Publisher DTP software.

Specification:

- 4Mb or 8Mb RAM expandable to 256Mb
- 1Mb VRAM for enhanced graphics
- Full support for 24-bit graphics – 16.7 million colours
- 14" Multiscan monitor as standard
- Impression Publisher DTP software
- Artworks graphics package

● 5M Publishing System	£1469	● 9M Publishing System	£1759
------------------------	-------	------------------------	-------

Acorn 32-bit RISC Computer Systems

A3010 Special Offers

A3010 Action Pack

includes computer with 1Mb RAM, expandable to 4Mb, Startwrite word processor, Zool game and demo versions of Lemmings, Fervour, Chuck Rock and Superpool.

only **£249**

A3010 Early Years

includes computer with 2Mb RAM, expandable to 4Mb, Talking Startwrite word processor, Gemini, Doris the Dotty Dog, Amazing Maths, Flossy the Frog, Mouse in Holland and Paint Pot.

only **£319**

A3010 Learning Curve

includes computer with 2Mb RAM, expandable to 4Mb, Acorn Advance integrated software suite, PC Emulator with DR DOS 6 and 8 demonstration versions of popular programs and games.

only **£329**

FREE Shoulder Bag with every A3010



Computer Systems

● A3020 2M FD System + AKF52 Monitor	£699
● A3020 2M HD System + AKF52 Monitor	£839
● A4000 2M HD105 + AKF52 Monitor	£839
● A4000 2M HD210 + AKF52 Monitor	£869
● A4 4M HD60 Notebook	£1599

Upgrade Options

● Upgrade to AKF50 Monitor	£120
● Learning Curve Software Pack	£39
● Home Office Software Pack	£85
● Early Years Software Pack	£39

TO ORDER CALL OUR SALES HOTLINE
or FAX YOUR ORDER on 01582 488588

01582 745555



CD-ROM, Multimedia, Scanners & Monitors

CD-ROM Software

Some titles require additional software to run under RISC OS. These are marked as follows:
EB—Electronic Books; **PaperOut** software required
PD—PDSView software required

- PDSView £99
- PaperOut — Electronic Book player £49

Art, Graphics & Design

- **Artworks v1.5** £122
- Artworks Clipart CD v1 £19
- Artworks Clipart CD v2 £19
- Art in the National Curriculum £75
- Pro Atrisan v2 £136

English & Literature

- Goldilocks £39
- Granny's Garden £30
- Illustrated Works of Shakespeare £23
- Karaoke Macbeth £49
- Karaoke Midsummer Night's Dream £49
- Living Poetry £49
- Listen & Read (EB) £39
- Oxford Reading Tree Talking Stories £39
- Sherlock Holmes £23
- Sherston Naughty Stories £79

Geography, Nature & Environment

- British Birds £150
- Creepy Crawlies £49
- Counties of Great Britain £39
- Countries of the World £39
- Dictionary of the Living World £49
- Earth Guide (EB) £39
- Environment: Land & Air £97
- Environment: Water £97
- Environment: Climate Change £34
- Environment: Dwindling Resources £34
- Environment: Conservation £34
- Garden Wildlife £39
- Langdale Primary £99
- Map Skills £49
- Seashore Life £39
- The Physical World £97
- Usborne Exploring Nature £125
- The World's Weather £47

History

- Castles £39
- Changing Times £125
- Frontier 2000 £109
- Industrial Revolution £105
- Medieval Realms £145
- Photobase: Victorians £49
- Picturebase: Victorian Britain £99
- World War II: Global Conflict £97
- World War II: Sources & Analysis £97
- World of the Vikings £39

Languages

- Directions 2000: French £137
- En Marcha: Spanish £137

Mathematics

- Cars — Maths in Motion £49
- Number Games £79
- Perspectives £79
- Picture Gallery £79
- Who Stole the Decimal Point? £79

Science & Technology

- Chemistry Set £149
- Science & Technology Library (EB) £39
- Collins Electronic Food File (EB) £29
- Science Series: Elements £97
- Science Series: Materials £97
- Inventors & Inventions £147
- Photobase: Science £49
- Understanding the Body £39
- Understanding Energy £47

Space & Astronomy

- Space Encyclopaedia £34
- Space Science Sampler (PD) £40
- Voyager Spacecraft (PD) £200

Educational Resources

- Acorn Video Collection Disc 1 £10
- Acorn Video Collection Disc 2 £10
- Bitfolio 6 - clipart images £49
- Horizon Report £19
- Photobase: 1920's £49
- Photobase: 1930's £49
- Photobase: 1940's £49
- Photobase: 1950's £49
- Photobase: 1960's £49
- Photobase: Landscapes £49
- Sermec Treasure Chest £69
- SEREC Graphics Collection £99

Dictionaries & Encyclopaedia

- 19th Century Biographies £25
- CIA World Fact Book (EB) £29
- Oxford English Dictionary (EB) £29
- Hutchinson Gallup Info (EB) £29
- Hutchinson Guide to the World (EB) £29
- Hutchinson Encyclopaedia £45
- Kingfisher Children's Micropedia £85
- Times & Sunday Times £178
- Times & Sunday Times Sampler £50
- Tekkie CD - Acorn PRM's on CD £99

CD-ROM Drives



Cumana Oscar CD-ROM Drive

- Dual speed drive with motorised drawer
- Kodak PhotoCD compatible
- 320ms access time
- Connects to parallel printer port

Oscar CD-ROM drive £199

Cumana Bravo CD-ROM Drive

- Dual speed drive with motorised drawer
- Kodak PhotoCD compatible
- 320ms access time
- Parallel port or SLCD versions

Bravo CD-ROM drive—Parallel port £249

Bravo CD-ROM drive—A3000 SLCD £249

Bravo CD-ROM drive—A5000 SLCD £249

Bravo CD-ROM drive—EMU SLCD £249

Optional CD Bundles

Bundle packs are only available at these prices when purchased with a CD drive.

Starter Pack

- Acorn VideoClip Collection CD
- Artworks Clipart CD
- Horizon Report
- Clares Pro Artisan v2 CD

£99

Primary Pack 1

- Creepy Crawlies CD
- Cumana Photo Album v1 CD
- Dictionary of the Living World CD
- Goldilocks CD
- Granny's Garden CD
- Sermec Treasure Chest CD

£175

Primary Pack 2

- Artworks Clipart CD
- Cars: Maths in Motion CD
- Sherston Naughty Stories CD
- Space Encyclopaedia CD
- Clares Pro Artisan v2 CD
- Hutchinson Encyclopaedia CD

£250



All Cumana CD-ROM drives are supplied with all necessary connecting cables, driver software and interface cards.

Cumana Victor CD-ROM Drive

- Dual speed multi-session drive
- Kodak PhotoCD compatible
- 320ms (402A), 210ms (632A) access time
- SCSI interface (not included)

CXX402A CD-ROM drive £289

The 602 and 604 CD-ROM drives employ a 6 disc autochanger, making it ideal for use on a network. 604 model is Quad speed.

CXX602 Autochanger CD-ROM £449

CXX604 Autochanger CD-ROM £849

Cumana Indigo CD-ROM Drive

- Dual speed multi-session drive
- Kodak PhotoCD compatible
- 320ms access time
- Connects to IDE Interface
- Fits in 5.25" drive bay inside RiscPC

CAA300I CD-ROM drive £189

CAA300IA CD-ROM drive £199

A version of the Indigo is also available for connection to a standard SCSI interface.

CAA401 CD-ROM drive £189

Speakers & Accessories



- Aries Stereo Speakers £9
- Aries Hi-Fi Stereo Speakers £29
- Aries Hi-Fi Pro Stereo Speakers £35
- Aries Digital Stereo Speakers £49
- Aries Digital Plus Stereo Speakers £59
- Aries Screen Microphone £4.50
- Aries Stereo Headphones £4.50

Aries Monitors



- EnergyPro 14" SuperVGA Monitor**
- 14" high res 0.28mm dot pitch tube
 - Low radiation MPRII standard
 - EPA Energy Star compliant
 - 800 x 600 non-interlaced resolution
 - Horizontal frequency: 29KHz - 38KHz
- £165

- Alphascan Pro LR 14" Monitor**
- 14" high res 0.28mm dot pitch tube
 - Low radiation MPRII standard
 - 1024 x 768 @ 72Hz (non-interlaced)
 - 1280 x 1024 @ 60Hz (non-interlaced)
 - Horizontal frequency: 29KHz - 70KHz
- £199

- EnergyPro 6000I 15" Monitor**
- 15" high res 0.28mm dot pitch tube
 - Low radiation MPRII standard
 - EPA Energy Star compliant
 - 1280 x 1024 @ 60Hz (non-interlaced)
 - Microprocessor control
 - Horizontal frequency: 29KHz - 70KHz
- £259

- EnergyPro 7560I 17" Monitor**
- 17" high res 0.28mm dot pitch tube
 - Low radiation MPRII standard
 - EPA Energy Star compliant
 - 1280 x 1024 @ 60Hz (non-interlaced)
 - Microprocessor control
 - Horizontal frequency: 29KHz - 80KHz
- £479

To use the above monitors with an A300, A400 or A3000 machine, you will need a SuperVGA VIDC Enhancer and adaptor.

- SuperVGA VIDC Enhancer £29
- Multiscan VIDC Enhancer £15
- Arc to VGA Monitor Adaptor £9

Acorn Monitors

- AKF30 — 14" Med Res RGB £179
- AKF40 — 14" Med Res RGB £179
- AKF52 — 14" Med Res Multiscan £249
- AKF50 — 14" High Res Multiscan £299
- AKF60 — 14" High Res SVGA £319
- AKF85 — 17" High Res Multiscan £969

Flatbed & Hand Scanners

Canon IX-4015 Colour Scanner

The IX-4015 is a compact A4 flatbed scanner offering full 24-bit colour scanning up to a max resolution of 400 x 800 dpi. The scanner will also scan 256 grey scale images with a max resolution of 400 x 1200 dpi.

- 400 x 800 dpi resolution in colour
- 400 x 1200 dpi resolution in monochrome
- Connection via SCSI interface
- Spacotech Photodesk software
- TWAIN driver & Sleuth OCR software

£699

Aries ArcScan 3420 Scanner

The ArcScan 3420 is an A4 flatbed scanner for those who just want to use 256 grey scale images. With a resolution of 300 x 600 dpi it will provide high quality images for a fraction of the cost of other similar models.

- 300 x 600 dpi resolution
- 256 grey scale or monochrome operation
- 216 X 356mm overall scanning area
- Connection via SCSI-2 interface
- ImageMaster software & TWAIN driver

£399

- Upgrade to Photodesk software £129
- SCSI-2 Interface for above £159

HP ScanJet Ilcx Colour Scanner

The ScanJet Ilcx is an A4 flatbed scanner capable of producing full 24-bit colour scans at a resolution of up to 1600 dpi.

- 400 x 800 optical resolution
- Single pass scanning process
- 24-bit colour and grey scale modes
- A4 scanning area (216 x 297mm)
- Connection via SCSI interface
- Spacotech Photodesk software
- TWAIN driver

£849

Accessories

- Document Feeders**
- Auto Document Feeder — IX-4015 £249
 - Auto Document Feeder — ArcScan £259
 - Auto Document Feeder — ScanJet Ilcx £365
 - Transparency Adaptor — ScanJet Ilcx £499

SCSI Interfaces

- 16-bit SCSI Interface (A300/A400) £79
- 32-bit SCSI-2 Interface (A300/A400) £159
- SCSI-2 Interface Cable £20

- Software**
- Spacotech Photodesk software £149
 - Sleuth OCR software £40

Scan256 Hand Scanner

Scan256 is a hand-held scanner giving you up to 256 grey scales at a maximum resolution of 400 dpi, and is supported by state-of-the-art software.

- 400mm scanning width
- 256 grey scales at up to 400 dpi resolution
- Highly advanced image processing tools
- Convoluting digital filters — over 100 choices
- True brightness & contrast control
- Save image in industry standard formats
- Selectable 256 grey/monochrome modes
- Ability to shear and/or rotate images

- Scan256 handscanner — A300/A400 £115
- Scan256 handscanner — A3000 ext. £125

Archimedes A4 Scanner

The Archi A4 scanner is a low cost 64 grey scale scanner with a scan width of up to A4 size. With a maximum resolution of 400 dpi. It is the ideal solution for scanning larger line art drawings. The scanner can be used as either a hand-held device or with an optional sheet feeder.

- Archi A4 Scanner — A300/A400 £175
- Archi A4 Scanner — A3000 external £195
- Sheet Feeder for A4 Scanner £59

TO ORDER CALL OUR SALES HOTLINE
 or FAX YOUR ORDER on 01582 488588

01582 745555



Hard Drives, Memory, Networking & Add-Ons

Hard Drive Upgrades

IDE Hard Drive Upgrades for A300/A400
Complete with drive, interface, mounting brackets, cables and software.

• ADA0580	365Mb	13ms	£179
• ADA2030	420Mb	12ms	£199
• ADA2210	540Mb	11ms	£219

IDE Hard Drive Upgrades for A5000
For use as a replacement of existing drive.

• ADA0880	365Mb	13ms	£119
• ADA2060	420Mb	12ms	£149
• ADA2220	540Mb	11ms	£159
• A5000 2nd Drive Kit			£10

A3000/A3010 Internal IDE Hard Drives

• ADA0730	120Mb	19ms	£179
• ADA2360	170Mb	13ms	£199
• ADA2080	340Mb	11ms	£249
• ADA2200	510Mb	10ms	£399

A300/A400 IDE Hard Cards

Hard drive mounted on interface, complete with formatting software.

• ADA2380	170Mb	13ms	£209
• ADA2090	340Mb	11ms	£259
• ADA2230	510Mb	10ms	£409

SCSI Hard Drive Upgrade for A300/A400
Complete with 16-bit interface, drive, cables and mounting brackets.

• ADA2310	540Mb	11ms	£299
• ADA2320	1.0Gb	9ms	£499
• ADA2330	2.0Gb	10ms	£849

Interfaces & Accessories

• 16-bit IDE Interface - A300/A400	£39
• 8-bit IDE Interface - A3000/A3010	£49
• SCSI Interface - A300/A400	£79
• SCSI-2 Interface - A300/A400	£179
• 25way-50way SCSI round cable	£15
• 50way-50way SCSI round cable	£15
• 50way-50way SCSI-2 round cable	£20
• 50way-50way SCSI ribbon cable	£8

Memory Upgrades

Model	2Mb	4Mb	8Mb
• A3000	£49	£119	£269
• A3010	£59	£139	-
• A3020/A4000	-	£79	-
• A5000	-	£79	£269
• A540/R260	-	£249	-

All 8Mb upgrades require 4Mb to be fitted already

RiscPC Additional RAM Modules

• 2Mb	£79	• 4Mb	£119
• 8Mb	£259	• 16Mb	£399
• 32Mb	£poa	• 64Mb	£poa
• 1Mb VRAM	£99	• 2Mb VRAM	£159

RISC OS Upgrades

• RISC OS 3.1 Single User Upgrade	£73
• RISC OS 3.1 Hardware Kit	£21
• RISC OS 3.1 Bulk Software Pack	£319

Fax/Modems

• Aries XLink XL144e Fax Modem	£119
Complete with cable & ArcFax software	
• US Robotics Sportster 14.4	£159
Complete with cable & ArcFax software	

Graphic/Sound Cards

• Colour Card Gold	£239
• Chroma 500 Genlock Card	£419
• Chroma 150 PAL Encoder	£169
• Chroma Genlock Card	£209
• Hawk V9 MKII Digitiser	£189
• Eagle M2 Multimedia Card	£319
• Vision24 254-line Colour Digitiser	£99
• Vision24 508-line Colour Digitiser	£139
• CC TV Tuner Card	£89
• CC TV Tuner Card & Teletext	£159
• CC Movie Magic MPEG Card	£249
• Scanlight Video 256	£199
• Multiscan VIDC Enhancer	£15
• SuperVGA VIDC Enhancer	£29
• RiscPC 16-Bit Sound Card	£59

25MHz ARM3 Turbo Card



Buy ARM3 Turbo Card and RISC OS 3.1 Upgrade for only **£169**

Using the latest surface mount technology on a high quality 4 layer PCB, the ARM3 Turbo Card will increase the speed of your A300, A400 or A3000 computer by up to 6 times.

The upgrade can be fitted by the user in A300 and A400 machines, but for owners of the A3000 we can collect, fit and deliver your computer back for an additional £35.

Owners of A300 and old A440 models will require a MEMC1A upgrade to use the ARM3.

Special Offer Price **£129**

Ultimate Expansion

Need an internal hard disk drive and a user port on your A3000 or A3010, then look no further. The Ultimate Expansion System from HCCS is an internal podule with a user port as standard. Space is provided for a 2.5" IDE hard disk drive and three micro-podule slots are also provided for future expansion.

• Ultimate Expansion Interface	£39
• Ultimate Expansion Interface & IDE	£99
• Ultimate Expansion with 170Mb drive	£259
• Ultimate Expansion with 340Mb drive	£299

Micro-Podule for Ultimate Expansion

• SCSI Interface	£69
• Vision Colour Digitiser	£69
• ScanLight 256	£229
• MIDI Interface	£49
• Analogue Interface	£29

I/O Expansion Cards

• A3000 User Port/Analogue Card	£29
• A3000 User Port/MIDI Card	£44
• I/O Podule - User/Analogue/1MHz	£79
• A300/A400 User/Analogue Card	£35

Miscellaneous Add-ons

• 4way Backplane - A300 series	£22
• Archimedes Fan	£8
• A3000 Serial Port Upgrade (AKA18)	£19
• Arc to BBC Serial Link	£15
• MEMC1A Upgrade	£25
• Floating Point Accelerator - A5000	£99
• ArcLaser A4 1200dpi Laser Printer	£985
• ScanLight 256 - A3000 Internal	£199

2010 Concept Keyboard

• A4 Universal 2010 Concept Keyboard	£99
• A3 Universal 2010 Concept Keyboard	£109
• 2010 BBC User Port Cable	£12
• 2010 Archimedes Serial Port Cable	£12
• Concept Keyboard Designer software	£20

Accessories

Dustcovers & Carry Cases	
• A3000 Keyboard cover	£5
• A3000 Keyboard & Monitor cover	£9
• A300/A400 Micro & Monitor cover	£9
• A5000 Micro & Monitor cover	£9
• 14" Monitor cover	£6
• A3000/A3010 Carry Case	£10
• A4 Notebook Carry Case	£35

Mice & Joysticks	
• Archimedes Mk4 Mouse	£24
• Acorn Logitech Mouse	£29
• Voltmace Delta Cat Joystick	£25
• Quest Tracerball	£20
• Power Pad Single Joypad	£25
• Power Pad Dual Joypad	£34

Miscellaneous Accessories	
• A4 Notebook Battery Pack	£49
• A3000 Monitor Stand (WE)	£15
• A3000 Monitor Stand (Acorn)	£25
• A3000 External Podule Case	£10
• Archimedes Keyboard Extension Cable	£5
• Archimedes Mouse Port Splitter	£5

Educational Discounts
are available on most products to Schools, Colleges & Universities. Call for details.

Networking Products

Acorn Econet Products

• Econet Interface - A300/A400/A5000	£42
• Econet Interface - A3020/A4000	£49
• Econet Interface - RiscPC	£49
• Econet Interface - A4 Notebook	£49
• Econet Starter Kit	£135
• Econet Bridge	£239
• Econet Socket Kit (5pk)	£25
• 100m Econet Cable	£99
• Econet Station Lead (1.2m)	£4

Acorn Ethernet Products

• Ethernet Interface III - A5000	£149
• Ethernet Interface - RiscPC	£99

Acorn Access Peer to Peer Networking

• Acorn Access - A3000	£145
• Acorn Access - A3020/A4000	£145
• Acorn Access - A5000	£145
• Acorn Access - RiscPC	£119

I-Cubed Ethernet Products

• EtherLan 102 - A3000/A3010	£129
• EtherLan 202 - A3020/A4000	£136
• EtherLan 502 - A300/A400/A5000	£129
• EtherLan 602 - RiscPC 600	£109

I-Cubed AccessFlash Network

• AccessFlash 100 - A3000/A3010	£149
• AccessFlash 200 - A3020/A4000	£159
• AccessFlash 500 - A300/A400/A5000	£149
• AccessFlash 600 - RiscPC 600	£139

Ethernet Hubs

• Aries EH-8 8 port Ethernet Hub	£179
• Aries EH-12 12 port Ethernet Hub	£259
• Aries EH-16 16 port Ethernet Hub	£329

Ethernet Cabling

Cable length	Thinnet	UTP
• 3m	£5	£3
• 5m	£6	£5
• 10m	£9	£8
• 15m	£12	£10
• 20m	£17	£14

Ethernet Accessories

• BNC Terminators	£1.25
• BNC In-line coupler	£1.55
• BNC T-connector	£2.00

Networking Software/Documentation

• AUN/Level 4 Fileserver Rel.3	£359
• TCP/IP Protocol Suite - single user	£99
• TCP/IP Protocol Suite - site licence	£399
• Level 4 Manager's Guide	£19
• AUN Manager's Guide	£19

PC Cards

Transform your Archimedes so you can run standard PC DOS or Windows based software with the Aleph One range of PC cards. Two models are available - 486SLC25 for general purpose applications or a 486SLC2-50 for greater performance.

Both versions come with interface connectors for a local IDE hard disk, a parallel printer port, serial port and there is also a socket provided for an optional maths co-processor. A single SIMM socket is provided and will accept RAM up to a maximum of 16Mb.

• 486 SLC25 PC Card - no RAM	£349
• 486 SLC25 PC Card - 4Mb RAM	£469
• 486 SLC2-50 PC Card - no RAM	£429
• 486 SLC2-50 PC Card - 4Mb RAM	£549
• 8Mb SIMM RAM for above	£259
• 16Mb SIMM RAM for above	£399
• 486SX33 PC Card - RiscPC 600	£199
• MS-DOS 6.2 & Windows 3.1	£89

Archimedes Spares

• A300/A400/A5000 Cased Keyboard	£99
• A3000/A3010/A3020 Keyboard	£29
• A4000 Cased Keyboard	£79
• Arc Mk2 Keyboard Controller PCB	£49
• A300/A400 Power Supply	£59
• A3000 Power Supply	£35
• A4000 Power Supply	£59
• A5000 Power Supply	£69
• 3.5" Floppy Drive - A3000/A400	£29
• 3.5" Floppy Drive - A4000/A5000	£35
• VIDC (VL86C310)	£39
• MEMC1A (VL86C110)	£29
• ARM2 8MHz CPU (VL86C010)	£20
• IOC (VL86C410)	£39
• 256K x 4 120ns ZIP DRAM	£6
• Replacement Keyboard Cable	£17
• Replacement Mouse Cable	£12
• Replacement Mouse Ball	£7
• 1.2v NiCad Battery - A3000/A5000	£4
• AA Batteries - A300/A400	£2
• Fan Filter & Clamp	£6
• Loudspeaker	£3
• A3010/A3020 FDD Eject Button	£2

BBC Products

• AMX Super Art (ROM/Disc)	£10
• AMX Stop Press (ROM/Disc)	£10
• AMX Page Fonts for Stop Press	£5
• AMX Mouse & FREE mouse mat	£15
• Quest Paint software (ROM/Disc)	£15
• ConQuest ROM	£12
• Quest Fonts Disc	£5
• Quest Integrex 132 printer driver	£5
• Quest Tracerball - BBC B/M128	£20
• Quest Mouse Mat	£3
• InterWord ROM	£36
• InterSheet ROM	£36
• InterChart ROM	£25
• Logotron Logo ROM	£40
• Mega3 ROM - Word/Sheet/Chart	£69
• Numerator ROM	£39
• Pendown ROM	£32
• SpellMaster ROM	£40
• Wapping Editor	£29
• Wapping Art Disc	£10
• Wapping Font Disc 1	£10
• Wapping Font Disc 2	£10
• View Printer Driver ROM	£15
• View 3.0 ROM	£45
• ViewSheet ROM	£36
• ViewStore ROM	£36
• ViewSpell ROM	£28
• View Printer Driver Generator Disk	£10
• Solderless ROM Board	£25
• 32K ROM/RAM Card - BBC B	£29
• 64K ROM/RAM Card - BBC B	£39
• 128K ROM/RAM Card - BBC B	£59
• 32K Shadow RAM Card - BBC B	£29
• 16K Static RAM for ROM/RAM Card	£8
• 16K DRAM upgrade for ROM/RAM	£7
• Battery backup for ROM/RAM Card	£3
• Sideways RAM Utilities Disc	£5
• Twin ROM Cartridge for Master 128	£6
• Quad ROM Cartridge for Master 128	£12
• Data Duck	£10
• Power Duck	£5
• Acorn 1772 DFS Kit - BBC B	£47
• Acorn ADFS ROM Upgrade	£25
• Acorn DNFS 1.20 ROM	£10
• Watford 1772 DDFS Kit - BBC B	£29
• BBC BASIC 2 ROM	£15
• Watford DFS 1.44 ROM	£10
• Watford Diagnostic Disc - BBC B	£10

BBC Spares

BBC B Spares	
• BBC B Power Supply	£49
• BBC Keyboard	£35
• Keyswitches	£1
• Function Keystrip Holder	£3
• Serial/Video ULAs	£10
• 6502A CPU	£5
• 6522A VIA	£5
• 6845 CRTC	£10
• 6850 ACIA	£8
Master 128 Spares	
• Master 128 Keyboard	£62
• Master 128 Battery Pack	£4
• Master 128 Power Supply	£69
• Master ULAs	£15
• 1772 Disc Controller	£10
• 6818 Real Time Clock	£12
• Loudspeaker	£3
• 655C12 CPU	£12

Please note that due to the lack of brand new spare parts for the BBC some of the above items may be reconditioned

TO ORDER CALL OUR SALES HOTLINE
or FAX YOUR ORDER on 01582 488588

01582 745555



Printers & Accessories

Laser Printers

All Laser printers (excluding Hewlett Packard Oki & Panasonic 4400/4401/5400) include 12 Months On-Site maintenance

• Brother HL630	6ppm	£326
• Brother HL660		£473
• Brother HL1260		£910
• Canon LBP 4i	4ppm	£395
• Canon LBP-8 IV	8ppm	£905
• Canon LBP-8 IIIIR	8ppm	£1559
• Epson EPL-3000	4ppm	£389
• Epson EPL-5200	6ppm	£462
• Epson EPL-5600	6ppm	£594
• Fujitsu VM600	6ppm	£499
• HP LaserJet 4L	4ppm	£386
• HP LaserJet 4 ML	4ppm	£734
• HP LaserJet 4MV	16ppm	£1989
• HP LaserJet 4V	16ppm	£1372
• HP LaserJet 4+	12ppm	£938
• HP LaserJet 4M+	12ppm	£1258
• HP LaserJet 4Si	16ppm	£2085
• HP LaserJet 4Si MX	16ppm	£2967
• NEC SuperScript 610+	6ppm	£289
• NEC SuperScript 660	6ppm	£416
• NEC SuperScript 660i	6ppm	£569
• NEC SuperScript Colour 3000	6ppm	£677
• OKI OL-400ex	4ppm	£289
• OKI OL-410ex	4ppm	£399
• OKI OL-850 PS	8ppm	£1199
• Panasonic KX-P4400	4ppm	£270
• Panasonic KX-P4401	4ppm	£330
• Panasonic KX-P4410*	5ppm	£318
• Panasonic KX-P4430*	5ppm	£479
• Panasonic KX-P4440*	10ppm	£679
• Panasonic KX-P5400	4ppm	£540
• Star WinType 4000	4ppm	£288

*2 years on-site warranty

Laser RAM Upgrades

Type	1M	2M	4M	8M
• Canon LBP-4+	£139	-	-	-
• Canon LBP-4i	£109	-	£279	-
• Canon LBP-8 IV	£119	-	£299	-
• EPL-4100/4300	£70	£110	£205	-
• EPL-5200/5800	£58	£115	£215	-
• Fujitsu VM600/VM4	£57	£85	£149	£299
• Fujitsu VM800	£115	-	-	-
• HP III/III/IIID	£75	£115	£135	-
• HP II/IIID	£75	£115	£135	-
• HP III/II	£57	£85	£158	£299
• HP 4/4M/4P/4MP	£85	£85	£149	£299
• HP 4L/4ML	£75	-	-	-
• KX-P4410/4430	£129	£199	-	-
• KX-P4420/4450i	£75	£115	£135	-
• KX-P4400/5400	£89	£139	£229	-
• OKI OL400e	£99	£118	-	-
• Star LP-8	£138	£225	-	-
• Star LS-5	£75	-	-	-

Laser Consumables

Type	Toner	Drum	Dev
• Brother HL630	£20	£99	-
• Canon/Star 4s	£46	-	-
• Canon LBP-8 IV	£70	-	-
• Canon LBP-8 III	£52	-	-
• EPL-4100/4300	£64	£89	-
• EPL-5200	£85	-	-
• EPL-7100/7500/8100	£117	-	-
• Fujitsu VM600	£85	-	-
• Fujitsu VM800	£115	-	-
• Fujitsu VM4	£29	£149	£89
• HP III/III/IIID	£47	-	-
• HP III/IIIP	£46	-	-
• HP III/II/4Si/MX	£77	-	-
• HP 4/4M	£67	-	-
• HP 4L/4ML/4P/4MP	£44	-	-
• HP 4V/MV	£115	-	-
• NEC 610	£79	-	-
• NEC S60/60P/62P/90/95	£105	-	-
• OKI OL-400/800	£19	£189	-
• OKI OL-400e	£17	£129	-
• KX-P4410/30	£28	£80	£90
• KX-P4440	£32	£108	£115
• KX-P4420	£24	£57	£55
• KX-P4450/50i/51/55	£18	£75	£60
• KX-P4400/5400	£11.50	£69	-
• Qume Crystalprint	£99	£189	-
• Star LS-5	£83	-	-

Laser Accessories

• JetPage Postscript Cartridge - IIP/IIIP	£169
• Postscript Upgrade for LaserJet 4	£270
• LaserJet 4 Lower Paper Cassette	£205
• LaserJet 4 JetDirect Ethernet Card	£339
• LaserJet IIP Lower Paper Cassette	£115
• Ozone filter for KX-P4420	£9
• Ozone filter for KX-P4450/4455	£20
• LaserJet 4Si Duplex Unit	£475
• Envelope Feeder for LaserJet 4	£199
• LaserJet Font Cartridges	from £45
• LaserJet III FX/IBM Emulation Cart.	£79
• Lower Paper Tray for Canon LBP-4	£98
• A5 Paper Feeder for LaserJet 4P	£85
• Postscript Upgrade for LaserJet 4P	£225

9pin Matrix Printers

• Citizen Swift 90	80col	£114
• Citizen Swift 90C	80col	£121
• Citizen 1200+ Parallel	80col	£90
• Citizen 120D+ Serial	80col	£105
• Epson LX100	80col	£108
• Epson LX300	80col	£88
• Epson LX400	80col	£89
• Epson LX1050	132col	£172
• Epson FX870	80col	£221
• Epson FX1170	132col	£280
• Epson DFX5000+	132col	£1099
• Panasonic KX-P1150	80col	£89
• Panasonic KX-P3696	80col	£259
• Star LC15	132col	£177
• Star LC100C	80col	£89
• Star LC90	80col	£89
• Star ZA200	80col	£255
• Star ZA250	132col	£315

24pin Matrix Printers

• Citizen ABC Mono	80col	£103
• Citizen ABC Colour	80col	£125
• Citizen Swift 200 Mono	80col	£138
• Citizen Swift 200 Colour	80col	£146
• Citizen Swift 240 Mono	80col	£160
• Citizen Swift 240 Colour	80col	£178
• Citizen Swift 24X	132col	£187
• Epson LQ100	80col	£97
• Epson LQ150 Mono	80col	£112
• Epson LQ150 Colour	80col	£158
• Epson LQ300	80col	£140
• Epson LQ570+	80col	£185
• Epson LQ870	80col	£350
• Epson LQ1070+	132col	£282
• Epson LQ1170	132col	£400
• Epson DLQ3000		£672
• Epson LQ3000	132col	£680
• NEC P2Q	80col	£98
• NEC P3Q	132col	£236
• NEC P62	80col	£315
• NEC P72	132col	£375
• NEC P90	132col	£549
• Panasonic KX-P2023	80col	£108
• Panasonic KX-P2124	80col	£198
• Panasonic KX-P1624	132col	£210
• Panasonic KX-P2135	80col	£124
• Panasonic KX-P3626	132col	£259
• Star LC24-20 II	80col	£113
• Star LC24-15 II	132col	£232
• Star LC24-300C	80col	£188
• Star LC240 Mono	80col	£92
• Star LC240 Colour	80col	£103
• Star XB24-200C	80col	£315
• Star XB24-250C	132col	£385

Ribbons/Ink Cartridges

(Manufacturers Original Ribbons Only)

Type	Black	Colour
• Canon BJ10ex/BJ10sx	£14	-
• Canon BJ200/BJ230	£16	-
• Canon BJ300/BJ330	£11	-
• Canon BJC600	£6	£7
• Canon BJC800	£16	£22
• Canon BJC4000	£7	£13
• Citizen 120D+	£4	-
• Citizen Swift 200/240	£4	£13
• Citizen Swift 24X	£8	£18
• Epson LX400/LX850/FX870	£4	-
• Epson LX100	£4	-
• Epson LX1050/FX1170	£5	-
• Epson LQ100	£4	-
• Epson LQ150	£4	£12
• Epson LQ570/870	£5	-
• Epson LQ1070/1170	£8	-
• Epson LQ2550	£8	£16
• Epson SQ870/SQ1170	£21	-
• Epson Stylus Colour	£-	£29
• Epson Stylus 300	£12	-
• Epson Stylus 800/1000	£10	-
• Fujitsu DL1150/DL1250	£5	£7
• Fujitsu DL3600	£6	£12
• Fujitsu B100/B200	£18	-
• HP DeskJet Std Capacity	£-	£21
• HP DeskJet High Capacity	£20	-
• HP DeskJet 310	£15	£21
• HP DeskJet 1200	£20	£21
• HP PaintJet	£16	£18
• HP PaintJet XL300	£16	£18
• Kaga/Taxan KP810/815	£5	-
• NEC P88Q/P32Q	£8	-
• NEC P82/72/90	£8	£14
• Panasonic 1150/1170/1180	£7	-
• Panasonic 2180/23/24/35	£7	£14
• Panasonic 1824/2824	£8	-
• Panasonic KXP3626	£11	-
• Star LC10/LC20/LC100	£5	£9
• Star LC100/200	£5	£11
• Star LC24-20/24-100/24-200	£5	£12
• Star LC24-30	£8	£12
• Star XB24/ZA200/ZA250	£5	£12
• Star SJ48	£15	-
• Star SJ144 Thermal	£18	£18

Inkjet Printers

• Canon BJ10sx	80col	£145
• Canon BJ200	80col	£186
• Canon BJ230	132col	£247
• Canon BJ300	80col	£361
• Canon BJ330	132col	£404
• Canon BJC600	80col	£344
• Canon BJC800	132col	£1065
• Canon BJC200 (Mac)	132col	£1228
• Canon BJC4000 Colour		£270
• Citizen ProjJet IIC		£219
• Epson Stylus 300	80col	£138
• Epson Stylus 400	80col	£130
• Epson Stylus 800+	80col	£168
• Epson Stylus 1000	132col	£311
• Epson Stylus Colour	80col	£327
• Epson SQ870	80col	£415
• Epson SQ1170	132col	£580
• Fujitsu B100	80col	£145
• HP DeskJet 320		£165
• HP DeskJet 320 & CSF		£180
• HP DeskJet 540	80col	£POA
• HP DeskJet 560C	80col	£326
• HP DeskJet 1200C	80col	£630
• HP DeskJet 1200C PS	80col	£992
• HP PaintJet XL300+ A4	132col	£1599
• HP PaintJet XL300+ A3		£1769
• HP PaintJet XL300 PS A4	132col	£2568
• HP PaintJet XL300 PS A3		£2719
• HP DeskWriter 520 (Mac)	80col	£199
• HP DeskWriter 500C (Mac)	80col	£260
• HP DeskWriter 560C (Mac)	80col	£387
• Star SJ48	80col	£182
• Star SJ144	80col	£285
• Star Wintype 800C Thermal Colour		£592

Sheet Feeders

• Canon BJ10ex/BJ10sx	£40
• Canon BJ300	£88
• Canon BJ330	£92
• Citizen Swift 24/200/240	£75
• Epson LX400	£69
• Epson LQ570/LQ870	£47
• Epson LQ1070/LQ1170	£89
• HP DeskJet 310	£48
• NEC P20/P220	£59
• NEC P30/P32Q	£85
• Panasonic 1170/1180/1123	£59
• Panasonic 1124/124i/2124	£79
• Panasonic 1824/2824	£128
• Panasonic KX-P2135	£30
• Star LC100	£69
• Star LC24-20	£69
• Star LC200/LC24-200	£69

INKJET REFILL PACKS FOR:

• Canon BJ10ex/BJ10sx - 2 pack	£12
• Canon BJ10ex/BJ10sx - 5 pack	£24
• Canon BJ10ex Cart & 3 Refills	£29
• Canon BJ200 Cart & 3 Refills	£34
• HP DeskJet Std Capacity - 2 pack	£8
• HP DeskJet Hi-Capacity - 2 pack	£24
• HP DeskJet Std Capacity - 5 pack	£14
• HP DeskJet Hi-Capacity - 5 pack	£35
• HP DeskJet Colour - Cart & 4 Refills	£49

Accessories

• Citizen Swift 200/240/ABC Colour Kit	£32
• Citizen ProjJet II Cartridge	£3
• Canon BJ10sx Battery Pack	£32
• Epson OK Serial Interface	£29
• Epson 8K Serial Interface	£75
• Epson 32K Serial Interface	£95
• Epson LQ100 Tractor Unit	£29
• HP DeskJet FX Emulation Cartridge	£49
• HP DeskJet IBM Emulation Cartridge	£57
• HP DeskJet 256K RAM Cartridge	£45
• HP DeskJet 310 Black Cartridge	£14
• HP DeskJet 310 Battery Pack	£33
• HP DeskJet Carry Case	£49
• HP DeskJet 310 Colour Kit	£28
• HP DeskJet 1200 Postscript Upgrade	£499
• HP DeskJet Prestige Elite Fonts	£55
• HP DeskJet Letter Gothic Fonts	£56
• HP DeskJet 310 Parallel Cable	£12
• Panasonic Serial Interface	£49
• Panasonic 32K Buffer	£16
• Panasonic 2180/2123 Colour Kit	£30
• Star 8K Serial Interface - LC range	£52
• Star 8K Serial Interface - XB range	£39
• Star 32K Buffer - LC24/XB24	£52
• Dustcovers for 80col printers	£6
• Dustcovers for 132col printers	£9
• 51636G - 50 x DJ500 Transparencies	£35
• 51838J - 50 x DJ500 Glossy A4 Paper	£35
• 51630Z - 50 x DJ500 A4 Paper	£15
• Appletalk Printer Cable - 2m	£12
• Appletalk Interface for DeskJet 1200	£129
• Appletalk Interface for LaserJet III	£189

HP On-site Warranty 3yrs

• Mono DeskJets & Deskwriters	£40
• Colour DeskJets & Deskwriters	£85
• 4ppm LaserJets & DeskJet 1200C	£100
• 8ppm LaserJets	£185

LUTON SHOWROOM

Finway, Dallow Road, Luton, Beds.

Tel: 01582 74 55 55

WATFORD SHOWROOM

250 Lower High Street, Watford, Herts.

Tel: 01923 23 77 74

Manual Printer Sharers

Standard Low Cost Sharers		
Connects	Serial	Parallel
• 2 to 1	£8	£9
• 3 to 1	£11	£12
• 4 to 1	£15	£16
• 5 to 1	£27	£28

Professional Sharers		
Connects	Serial	Parallel
• 2 to 1	£12	£13
• 3 to 1	£15	£17
• 4 to 1	£24	£26
• 5 to 1	-	£38

Crossover Sharers

Connects	Serial	Parallel
• 2 in/2 out	£28	£29
• 4 in/2 out	-	£49

Auto Printer Sharers

Uni-Directional		
Connects	Serial	Parallel
• 2 to 1	£27	£29
• 4 to 1	£44	£45
• 8 to 1	£62	£75

Bi-Directional		
Connects	Serial	Parallel

Software, Books & Diskettes

Software for Acorn RISC Computer Systems

As one of the largest dealer in Acorn software in the UK, we doubt that you will find any of the titles listed here cheaper elsewhere.

Also if there is something you don't see listed, give us a call and we will attempt to source it for you and give you the best price.

All software requires at least 1Mb RAM and RISC OS operating system.

Special notes
 † - not suitable for RiscPC
 †† - requires 2Mb RAM
 ‡ - hard disk required

Games

4th Dimension	
Adventures of Sylvia Lane	£16
Birds of War †	£22
Black Angel	£22
Break 147 & Superpool	£22
Carnage Inc.	£16
Chocks Away Compendium †	£15
Chopper Force	£18
Cyber Chess	£18
Demon's Lair	£18
Dungeon ††	£18
Enter the Realm †	£18
E-Type II	£22
E-Type Compendium	£15
Galactic Dan	£15
Greivous Bodily ARM	£15
Haunted House	£18
Holed Out Compendium	£18
Pandora's Box	£15
Real McCoy 2	£20
Real McCoy 3	£20
Real McCoy 4	£20
Saloon Cars Deluxe	£20
Stunt Racer 2000 †	£18
Stunt Racer 2000 Extra Tracks †	£18
Time Machine	£14
Virtual Golf †	£18
Virtual Golf Augusta †	£12
Watford Learn & Play Pack	£40

Krisalis Software	
Battle Chess	£17
Cannon Fodder	£17
Champions	£20
Chuck Rock	£8
Gods †	£8
Hero Quest	£18
Heimdall ††	£18
James Pond †	£8
Krisalis Collection	£20
Lemmings	£14
Lemmings 2 - The Tribes	£18
Lemmings Double Pack - RiscPC	£21
Lotus Turbo Challenge II †	£18
Mad Professor Mariati	£8
Manchester United †	£8
Manchester United Europe †	£8
Nabulus	£14
Oh No! More Lemmings	£12
Populous	£18
Quest for Gold (HD)	£10
Revelations	£8
Sim City	£18
Sim City 2000	£25
Sim City 2000 - RiscPC	£25
Speedball 2	£17
SWIV	£8

Gamesware	
Aries	£21
Cycloids	£14
FRED	£14
Games Wizard	£18
Ixon	£14
James Pond 2 - Robocod	£18
Playdays	£18
Simon the Sorcerer	£29
Xenon 2	£18
Renegade	
Chaos Engine	£18
Magic Pockets	£17
Sensible Soccer	£18

Superior Software	
Air Supremacy	£14
Ego: Repton 4	£17
Play It Again Sam 1	£14
Play It Again Sam 2	£14
Play It Again Sam 3	£14
Repton 3	£14
Superior Golf	£14
Technodream	£14

US Gold	
Flashback	£18
Flashback HD	£18

Gremlin Graphics	
Premier Manager	£18

Oregon Software	
Arcturus	£21
Magnetoids	£21
Sally & Wally	£21

Other Software Suppliers	
Chess 3D	£18
Crystal Maze	£24
Diggers	£18
Dune II ††	£29
Elite	£29
PTT	£21
Scrabble	£18
Starfighter 3000	£22
Tower of Babel	£10
Wolfenstein 3D	£22

Educational Software

Primary - ages 4 to 7 years

An Eye for Spelling	£32
Bookstore Primary	£33
Connections	£23
Desktop Folio	£59
Exploring with Flossy the Frog	£34
Folio	£22
Fun School 3 - Under 5 years	£17
Fun School 3 - 5 to 7 years	£17
Fun School 4 - Under 5 years	£17
Fun School 4 - 5 to 7 years	£17
Happy Life	£17
Happy Numbers	£25
Happy Reading	£25
Happy Sea	£25
Happy Time	£25
Kid Pix	£34
Letters	£42
Maths Circus	£25
Numbertime	£24
Oxford Talking Stories - Stage 2	£32
Oxford More Talking Stories - Stage 2	£32
Oxford Talking Stories - Stage 3	£32
Playdays	£18
Picture Point	£26
Podd - English version	£23
Podd - Welsh & English version	£36
Primary Nature	£42
PIMS - Information Management	£375
Rainbow	£27
Rainbow Book Project - Fiction 1	£69
Rainbow Book Project - Language 1	£69
Rainbow Book Project - Non Fiction 1	£69
Rosie & Jim - Duck Loses His Quack	£10
Rosie & Jim - Jim Gets the Sneezes	£10
Seelinks - Ourselves	£34
Seelinks - Pondwatch	£34
Seelinks - Transport	£34
Sherston Naughty Stories - vol.1	£39
Sherston Naughty Stories - vol.2	£39
Sherston Naughty Stories CD	£64
Talking Animated Alphabet	£27
Talking Topics - The Body	£10
Talking Topics - Dinosaurs	£10
Talking Topics - Homes	£10
Talking Topics - Land Transport	£10
Talking Topics - Pets	£10
Talking Topics - The Seaside	£10
Talking Topics - all six above titles	£49
Zig Zag - Anglo Saxon	£27
Zig Zag - Romans	£29

E-Type II

Rainbow	£27
Rainbow Book Project - Fiction 1	£69
Rainbow Book Project - Language 1	£69
Rainbow Book Project - Non Fiction 1	£69
Rosie & Jim - Duck Loses His Quack	£10
Rosie & Jim - Jim Gets the Sneezes	£10
Seelinks - Ourselves	£34
Seelinks - Pondwatch	£34
Seelinks - Transport	£34
Sherston Naughty Stories - vol.1	£39
Sherston Naughty Stories - vol.2	£39
Sherston Naughty Stories CD	£64
Talking Animated Alphabet	£27
Talking Topics - The Body	£10
Talking Topics - Dinosaurs	£10
Talking Topics - Homes	£10
Talking Topics - Land Transport	£10
Talking Topics - Pets	£10
Talking Topics - The Seaside	£10
Talking Topics - all six above titles	£49
Zig Zag - Anglo Saxon	£27
Zig Zag - Romans	£29

Junior - ages 7 to 11

A Mouse in Holland	£22
Ancient Egypt	£42
Arcture 1 - Romans	£24
Arcture 2 - Egyptians	£24
Arcture 3 - Vikings	£24
Around the World in 80 Days	£31
Aztec	£31
Badger Trails	£31
Battle of the Somme	£42
Bodywise	£31
Castle Life	£42
Crystal Rain Forest	£31
Fun School 3 - Over 7 years	£17
Fun School 4 - Over 7 years	£17
Graph IT	£16
Investigating Maths	£32
Junior Insight	£40
Landmarks - Aztecs	£21
Landmarks - Civil War	£21
Landmarks - Columbus	£21
Landmarks - Elizabeth I	£21
Landmarks - Project Egypt	£21
Landmarks - Rain Forest	£21
Landmarks - Victorians	£21
Landmarks - World War II	£21
Landmarks Databases - various titles	£13
Langdale River Project	£45
Langdale Stickle Tam Project	£45
Linkword - French	£35
Linkword - German	£35
Linkword - Spanish	£35
Look & Read - Earthwar	£24
Look & Read - Goodye Racer	£24
Look & Read - LRTV	£24
Look & Read - Skyhunter	£24
Look & Read - Through Dragon's Eye	£24
Magpie 2	£49
Maths Card	£45
Microworlds - Victorians	£24
Microworlds - War Years	£24
Numerator	£32
Numerator - RiscPC only	£32
Numerator Chaos Pack	£32
Recall	£31
Report Writer	£45
Saxon Life	£42
Sea Rescue - Fractions	£42
Selladore Tales	£19
Space City - Angles	£34
Splash	£16
Slig of the Dump	£19
Time Detectives - Victorians	£31
Topographer	£59
VersaTile	£42
Viewpoints	£31
Viking Invaders	£42
Voyage of Discovery	£25
World Map Study	£55
Time Traveller - Britain Since 1930's	£29
Time Traveller - Making of the UK	£29
Time Traveller - Medieval Realms	£29
Time Traveller - Tudors & Stuarts	£29
Time Traveller - Trade and Industry	£29
Time Traveller - Victorians	£29

Secondary - ages 11 to 16 years

Bookstore Secondary	£52
Cistercian Abbeys	£42
Investigating Local Industry	£85
Insight	£62
Night Sky	£59

Educational cont'd...

10 Out of 10 Educational Software

Dinosaurs	£15
Driving Test	£15
Early Essentials	£15
English	£15
Essential Maths	£15
Essential Science	£15
French	£15
German	£15
Italian	£15
Junior Essentials	£15
Maths - Algebra	£25
Maths - Geometry	£15
Maths - Number	£15
Maths - Statistics	£15
Spanish	£15
Spelling & Punctuation	£15
Structured Spelling	£15

Desktop Publishing

Impression Style	£73
Impression Publisher	£122
Impression Publisher Plus	£219
Impression Borders Disk	£12
Ovation DTP	£68
First Page DTP	£41

DTP Utilities

Desktop Thesaurus	£16
Formulix	£65
Graphics Loaders	£35
Slueth OCR v1.5	£43
Slueth OCR v2.0	£95
Spellmaster	£25
Type Studio	£38

Word Processors

DeskEdit 4	£21
Easiword Plus	£36
Easiwriter 3	£115
Pendown	£45
Pendown Etoiles	£45
Pendown Plus	£66
Primeword	£42
Talking Pendown	£53
Techwriter	£164
Wordz	£54
Wordworks	£35

Integrated Packages

Acorn Advance	£87
Desktop Office	£48
Fireworkz	£89
Fireworkz Pro	£145
Pipedream 3	£69
Pipedream 4	£85

Spreadsheets

Advantage ††	£42
Eureka 3	£91
ProSheet v1.4	£33
Resultz	£74
Schema 2	£94

Databases

Flexifile	£19
Insight	£58
Genesis Project	£47
Genesis Professional	£111
Knowledge Organiser 2	£60
Masterfile 3	£39
Pinpoint 2	£78
Pinpoint Junior	£25
Recordz	£96
S-Base 2 Personal	£103
S-Base 2 Developer	£188
S-Base 2 Developer Plus	£339

Graphics & Design

Artworks v1.5	£122
Card Shop	£19
Clipart - Christmas Allsorts	£15
Clipart - Food for Thought	£15
Clipart - Split an Image	£15
Complete Animator	£94
Composition - RiscPC only	£184
Euclid 2	£82
FILMAKER v5.1	£39
Glimpse - clipart viewer	£8
Image Animator	£45
Image Outliner	£45
Image Master	£25
Illusionist	£37
Kid Pix	£34
Photodesk	£149
Prime Art	£46
Pro Artisan 2	£99
Pro Artisan 24 - RiscPC only	£122
Render Bender 2	£37
Rephorm	£44
Revelation Image Pro 24-bit	£49
SolidRENDER v5.1	£63
SolidTOOLS v5.1	£169
Tiltler	£72

Educational Customers

Most of the software packages on this page are available at reduced prices to educational establishments. Also, for those who need more than one user at any one time, Site Licences are available on most packages. Call 01582 745555 for latest prices.

Graphics Presentation

Chartwell	£22
Graphbox	£35
Graphbox Professional	£84
Plot	£61
Presenter GTI 16v	£69

Computer Aided Design

ArcPCB v1.9	£80
ArcPCB Professional v3.3	£162
ArcPCB Schematics v5.2	£223
CADet	£95
ExcellonDRILL v2.1	£36
GerberPLOT v2.1	£36
LOGIX v1.1	£80
Oak Logic	£65
Oak PCB II	£69
Oak Apollonius PDT	£135
Oak Design Processor 3	£1150
PowerROUTER v1.6	£49
SolidCAD v5.1	£65
WorraCAD	£65

Programming Tools

Acorn Desktop Assembler	£119
Acorn Desktop C	£151
Acorn PC Emulator v1.8	£89
ABC Basic Compiler v3	£65
Cambridge Pascal	£65
Control LOGO	£21
Easy C Compiler	£43
Easy C++ Compiler	£95
First LOGO	£20
Logotron LOGO	£55
RiscBASIC Compiler v3.15	£65
RiscFORTH Compiler v1.2	£65
RoboLOGO v1.1	£35
WimpGEN v1.1	£65

Music & Speech

Articulate	£15
Audioworks	£35
Notate	£51
Rhapsody 3	£72
Rhythm Bed	£35
Serenade	£44
Sibelius 6	£72
Sibelius 7	£149
Speech!	£785
Vox Box	£18

Communications

ArcComm 2	£52
ArcFAX	£30
ArcTerm v7	£59
Hearsay v2	£59

Business/Accounts

Home Accounts	£24
Payroll Manager v3	£59
Personal Accounts	£39
PLANING	£289
ProjectING	£289
Prophet Accounts ††	£144
Shareholder v2	£69
Shareholder Professional v3	£110

Miscellaneous

Ancestry	£42
Compression	£31
Concept Keyboard Designer	£21
File Handling for All Disc	£4
Hard Disc Companion 2	£39
Investigator 3	£41
MacFS Light - read/write floppies	£45
MacFS	£89
PaperOut - Electronic Book player	£49
PDSView	£99
Risc OS Application Disks	£5
ROM Upgrade for Acorn I/O Module	£10
Show Page	£139
Touch Type	£39
TWAIN - HP, Canon or Epson	£16
WIMP Programming for All Disc	£4

Printer Drivers

Citizen/Star Colour Printer Driver	£10
Expression PS	£18
HP DeskJet Colour Printer Driver	£10
IPrinters v1.22 Upgrade Disk	£5
Canon BJ Turbdriver v4 †	£38
Epson Stylus Turbdriver v4 †	£38
HP DeskJet Turbdriver v4 †	£45
Repro	£45

Books & Diskettes

Acorn 32-bit Books

A3000 Technical Manual	£29
A3010/A3020 Tech Manual	£29
A5000 Technical Manual	£59
A4 Notebook Tech Manual	£59
Archimedes Assembly Lang	£15
Acorn to PC	£2
Artworks Made Easy	£14
ARM Technical Data Manual	£10
BBC BASIC Reference Guide C	£19
C: Dabhand Guide 3e	£15
Control on the Archimedes	£10
Ethernet Design/Installation Guide	£19
First Impressions	£15
File Handling for All	£8
Good Impressions	£12
Impression II: Dabhand Guide	£12
RISC OS 3 PRM - Vol.1 to 4	£95
RISC OS 3 PRM - Vol.5 (RiscPC	

*info

Dave Lawrence and Dave Acton present more programs, tips and techie trivia from beyond the PRM.

Fearful symmetry

Author: James Harvey

James Harvey of Harrogate has sent us another one of our popular chaotic pattern generators. This program draws chaotic symmetric icons and fractals. Given a series of values for various constants, it draws repeated iterations of a point.

'For the icons, the screen represents an Argand diagram of the complex plane,' says James. 'The iterations are as follows:

$$z' = (a + b.z.\bar{z} + c.Re(z^n)).z + d.z^{n-1} + e.zi$$

The fractals show the screen as an x-y plane. The iterations are repeated transformations:

$$\begin{pmatrix} x' \\ y' \end{pmatrix} = \begin{pmatrix} x \\ y \end{pmatrix} \begin{pmatrix} a_{11} & a_{22} \\ a_{21} & a_{22} \end{pmatrix} + \begin{pmatrix} b_1 \\ b_2 \end{pmatrix}$$

of a symmetry group either $D(n)$ or $Z(n)$.

'To start with, you can load some of the example patterns from the directory *Symmetries*. Drag any of the *FracDef* files to the main window and click the "Plot the fractal" button. For reasons of speed, the program will temporarily exit the desktop while the fractal is generated. Once the fractal has progressed sufficiently on screen you can press Space and the screen will revert back to the desktop.

'You can now bring up a menu to display the image in a window or save it as a sprite with a standard RISC OS save box. There is also a sub-menu off the display sprite entry which controls the size of the sprite displayed.

'Once you are happy with the operation of the program, you can start experimenting with the parameters. Press "View the variables" to bring up another

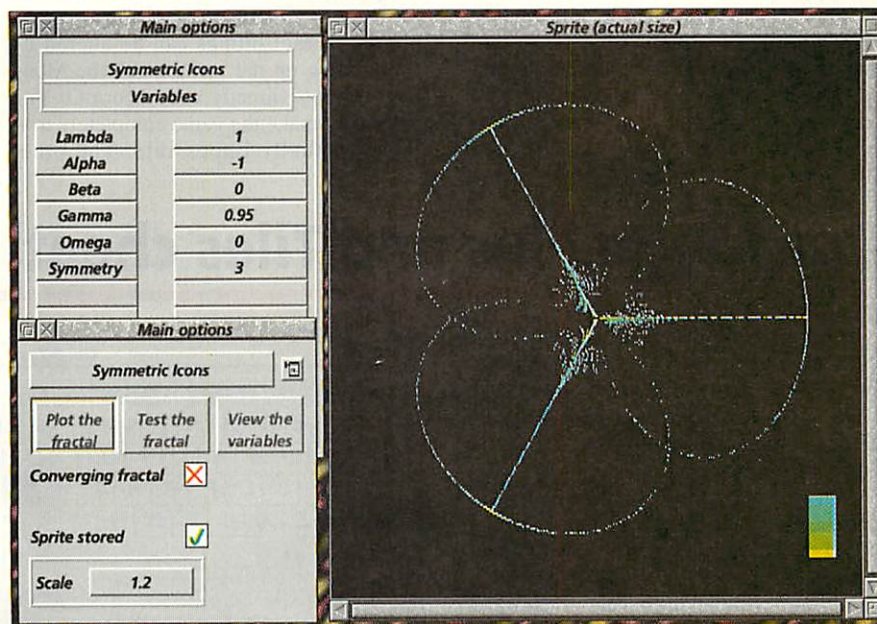

window which shows the parameters for the current fractal. You can alter any of these by inputting new variables into the writable icons. When you want to redisplay the fractal, press "Test the fractal." This will iterate the fractal a few times, check that it remains convergent, and auto-scale it – if you want your own scale, input a new value into the main window. You can then calculate the fractal. The sets of parameters can be saved as *FracDef* files from the main menu.

'The program was inspired by the book "Symmetry and Chaos" by Field and Golubitsky, which is very interesting if you are into that kind of thing. The

default files, as well as the equations themselves and the *I/FearN* files, also come from this book.'

3D problems

We've heard from a number of readers who have had problems with our *3DRamFree* utility from the Christmas issue and extend our apologies to all those concerned. We are awaiting advice from the author on what the problem was and hope to carry a new version soon. Sorry once again.

Pocket piece

Author: Dave Lawrence

Since the Acorn Pocket Book II has now 'arrived' we thought we might as well bring you some programs for it. We kick off this occasional series with a little game I originally wrote for the Psion 3a, but as it was based on a classic BBC game we thought it worthy of inclusion in *Acorn User*.

The original game was *Purple People Eaters*, but despite my best efforts – and a copy of the original program – I cannot find out who wrote it and when. If the author would like to step forward... As the Pocket Book II has no colour screen, I re-christened the game *Grey People Eaters* – hence the GPE abbreviation.

You will need to first copy the game to your PB2 either by transference or, more simply, with an A-Link. Put it in a VAPP directory and you should be able to install it on to the Desktop screen in the usual way with Acorn-I (or Psion-I). The game can then be started by selecting its icon with Enter.

The idea of the game is simple; you are stuck in an arena full of blocks and the eponymous People Eaters. People Eaters eat people, as is their wont. Fortunately they are not very bright (or strong) and cannot eat (or push) the aforementioned blocks, although you can. Losing the game is easy – get eaten. Winning the game involves building traps with the

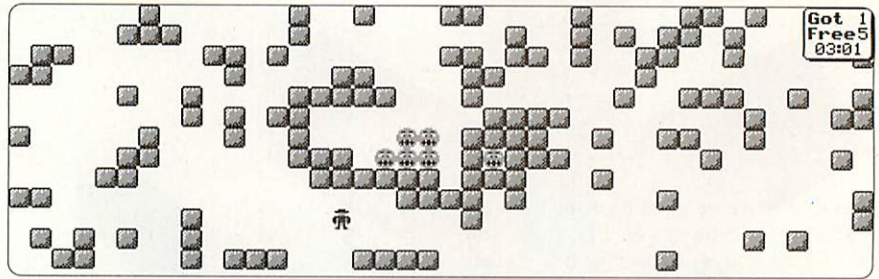

blocks and penning the People Eaters in so they can't move. When you have disabled them all, the game is over. Beware though, that it is surprisingly easy to unwittingly destroy one of your lures with a careless shove.

You move with the cursor keys and with Q, W, A & S if you're feeling adventurous and want to branch out into diagonal motion. The game will wait for you to make your first move before the People Eaters start chasing you, inexorably homing in on your delicious human flesh.

By default there are four slowish People Eaters chasing you and you are strong enough to push a line of three blocks. These settings can be altered by summoning up the menu (with the Menu key) or more directly with Acorn-O. You can easily make the game completely trivial or virtually impossible. The other

menu options should be self explanatory. A small status window is shown in the top right-hand corner of the screen which shows you how many People Eaters you have caught, how many are free and how long you have taken. Win or lose, Acorn-R will reset the arena for a new game.

Obviously we don't want to flood the pages of *INFO with PB2/P3 games, but if you have anything written you feel is even slightly Acorn do send it to us at the usual address. If, on the other hand, you're reading this thinking, but I *can't* write anything because the PB2 manual doesn't include anything about OPL (if you're *really* in the dark, this is the programming language built into the PB2), do not panic as we are currently planning a short series on OPL programming. In the meantime, has anyone got any requests for old BBC games to convert to PB2?

QuickType Plus and Tiles cheat

Author: Peter Bagnall

You may remember Peter Bagnall's *QuickType* module from the Christmas special. It allowed abbreviated typing à la Electron or Spectrum. Well, Mr Bagnall has now supplied a nice front-end to complement the module...

'Run *QuickType* and its icon will appear on the icon bar. If the module was already loaded then the current definitions are preserved, otherwise it loads the preset definitions. Now click Select on the icon and a window appears. This has a map of the keyboard on it. Double-click on a key and it is highlighted and the "Edit key" box shows that you are now editing that key. Type in the string you want to bind to that key, press Return (or click on the OK), and hey presto – it's done.

'If you want to define several keys with the same string, (heaven knows why you would), then click Select on the first and Adjust on all the others until they are all selected. Then click Menu, and choose "Edit Selection". If there is no selection then it will allow you to edit the key the pointer was over when you clicked Menu.

'The "Save Preset" option allows you to define what the preset key bindings are,

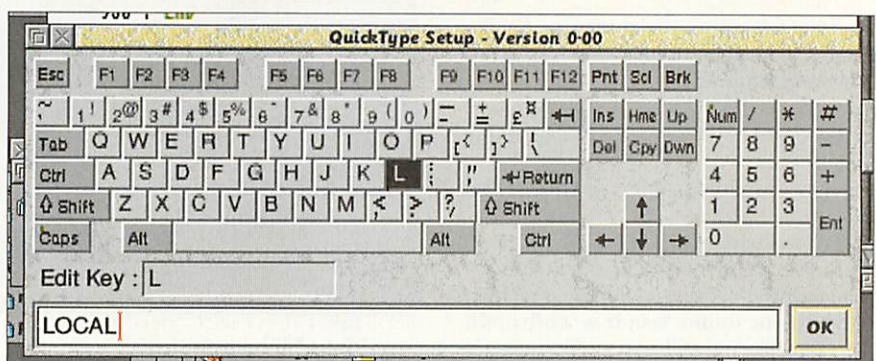

which means that all your favourite key bindings are available from one double-click. If, however, you use more than one set of key bindings, you'll need to be able to save other files than just the preset, which is what "Save" is for. This saves an Obey file, which can be run in its own right (as long as the module is loaded), to redefine a set of keys.'

Tiles cheat

Also hot out of Peter Bagnall's drive is this 'cheat' for Steve Gutteridge's *Tiles* game (AU May 1994). He wrote a short

program to generate saved two and three colour games with pieces carefully positioned so that there is a place for each possible tile to fit.

'The theory is quite simple. With two colours, $2^4=16$, i.e. 16 combinations, but since you only need to match three sides, 8 "traps" will get all possible combinations – you can probably do it with less. With three colours, 3^4 is 81, which is much more difficult, but again works, just. With four colours, 4^4 is 256, which I think could be pushing it a bit. Maybe I'll do it later, or does anyone else want a go?'

Risc PC specials

Author: Jan Vibe

Since the launch of Acorn's spanking new machines, we've had surprisingly few graphical oddities submitted that make use of the greater colours and resolutions available on the Risc PC. By means of encouraging all you shy Risc PC owners to get coding, here are a few old Jan Vibe demos that we've enhanced for the new machines. We hope you like them and feel inspired to write your own even better demos (and send them in to us of course).

24-bit colour sounds like a really good thing at first. When it comes to demos, the 16 million available hues aren't terribly useful though. If you have a mere 1Mb of VRAM (as I do) then the highest resolution you can get with 24-bit colour is a mere 480 by 352. Also, because each pixel takes a whole word of memory to define, doing certain things can be quite slow. Compared to a 16-colour mode for example, with eight pixels per word, a sprite of equal size would theoretically take eight times as long to plot. It's true that stills look spectacular in all their 24-bit glory, but apart from looking at pretty static images, the true 256-colour modes are actually much more useful when it comes to little demos.

This trio of revamped Vibe masterpieces is testament to this fact. Two use a true 256-colour mode (that is, a mode where the full 256 colours can be set to whatever colours you choose rather than be altered 'subtly' in groups of 16, as was the case with dear old mode 13), many demos involve palette-switching of some sort, or nice gradations of unusual colours, and for these purposes having 256 changeable hues instead of 16 makes a world of difference.

Tent256 is an even more disgusting version of Jan's original. A pink 'fleshy' sphere is drawn and grabbed as a sprite. It is then used at decreasing scale to plot wiggly tentacles all over the screen. It's worth looking at some features of the program to see how the change to 256 true colours has been made.

First the mode is selected with `PROCselect_mode`. You can of course use something like:

```
MODE "G256 X800 Y600"
```

but this actually changes the desktop mode, which is really annoying when you come back to find all your windows crunched up! It's better to define your own *mode selector* block. This contains a minimum of five words, as shown in figure one: in practice you need only worry



about the resolutions and pixel depth. Set the frame rate to -1 so it will be as high as possible. Mode variables need only be specified if you want to alter things like the X and Y eigen values. Otherwise, sensible defaults will be used.

There is an exception to this, which *Tent256* illustrates. If you ask for a 256 colour mode you will actually be given an *old style* mode by default. If you want a true 256 colour palette you have to add the pair of words (3,255) to your mode selector block to say 'maximum logical colour is 255' - a little contrived.

The old problems of GCOL values being different to colour numbers doesn't go away. In *Tent256* we change colours 1 to 255 to a pink-to-white scale but GCOL still takes its bits in a funny order with TINT nabbing two of them, so we use a conversion table built with the `ColourTrans_ColourNumberToGCOL` call.

Pearls256 shows how palette switching can be very effective in 256 colours. Like the original, the program works by plotting a large shaded ball, grabbing it, and

then plotting a series of smaller spheres which are grabbed from parts of the large one. It's a clever cheat to get good shading effects. The demo functions as before, except the `SYS call ColourTrans_WritePalette` is used to set the whole palette in one go. This is quicker than lots of `COLOUR r,g,b` commands. Because there are more shades, cycling is slower, so a few other tweaks have been applied so that the effect is still good.

This highlights one of the problems in converting demos. Sometimes the methods used simply don't translate properly. One example is Jan's *Guts* demo. This worked by plotting a sort of snake, which wormed - well, no, snaked I suppose - its way around the screen building up an intestinal masterpiece. With 256 colours instead of 16, the trail was so long it frequently curved back on itself and got the plotting wrong! We have converted a similar demo - *Ooze32K* - which builds up a sort of psychedelic lower intestine. Unlike the other two conversions, this uses a 32,000 colour mode - useful when you don't need palette switching but when limited VRAM means a 16-million colour postage-stamp.

If you can do better, which we're sure you can, send all Risc PC demos to the usual address please.

Figure one - Risc PC mode selector block

Offset	Contents
0	Flags - only bit zero is used and should be one meaning 'this is a real mode, not a sprite'
4	x resolution (pixels)
8	y resolution (pixels)
12	pixel depth - 0=1bpp, 1=2bpp, 2=4bpp, 3=8bpp, 4=16bpp, 5=32bpp
16	frame rate in Hz (-1 = highest available)
20+	pairs of mode variables (number, value), terminated with -1

Circumbendibus

Author: Andrew Bower

This is one of those little applications that often come in handy when you can't be bothered to stoke up *ArtWorks* or something similar to do the apparently trivial task of putting a string around a circle. Andrew Bower – aged 15 of Solihull – has written *CircleFit*. This is not a desktop program, but does everything you might need and is still easy to use. It works in any mode, so double-clicking from the desktop will run the program in your selected WIMP mode.

The output from the program can be saved as a *Draw* file or grabbed as a sprite. These files are saved in the currently selected directory, so make sure that this is set to a suitable place before running the program.

The body of the program is taken up with a series of options:

Font name: the name of the font to use.

Font size: the size of the text in points, remembering that one inch is approximately 72 points. You can change the aspect ratio of the text by entering two numbers separated by a colon: 'width:height'.

Text: the text you want wrapped.
Radius: the radius of the circle.
Start: the angle from which the text is drawn. Zero is east and angles go clockwise, so 90 is south and so on.

In all the above you can use the standard RISC OS editing keys – cursors, Delete, Copy, Ctrl-U and so on.

Once you have entered values for these the text is drawn and then the menu is displayed which allows you to adjust the parameters or save your work:

Draw: redraw the text.

Edit & Draw: re-edit the input parameters and then redraw the text.

Make Draw Path: Direct output to a *Draw* file. You *must* deselect this option before quitting.

Overlay: subsequent output will be merged with previous output.

Reverse writing: plot text on the other side of the circle.

Anti-clockwise: plot text backwards.

Move: move the base line of the text in relation to the radius of the circle entered.

Quit: leave the program.

To create a *Draw* file, fiddle with the various parameters until you are happy with the settings, select 'Make Draw Path', *Draw* to redraw the text then deselect 'Make Draw Path'.

Some additional notes:

Because the circles are exported with the text, the whole lot can be grouped and rotated without the circumcentre moving.

SWI "Font_SetPalette" is used in 16-colour modes to give a couple of anti-alias shades to every colour. SWI "Font_Switch OutputToBuffer" is used to divert Font calls then create *Draw* paths. The actual rotation work is done by calls to SWI "Font_Paint" with a transformation matrix.

Andrew says: 'The *Draw* module is used to draw the circles, but I do not know enough about Bezier curves to create a true circular circle, so I experimented and in the end made the control points a factor of 1.5625 of the radius away from the start/end points. I would be grateful if someone could enlighten me as to the correct method here.'

Fractal frolics

Author: Alistair Turnbull

This latest fractal demo comes courtesy of regular Alistair Turnbull. *FractalLand* is a real-time fractal landscape so if you've got a good bit of RAM free – you will need to set the 'Next' slot on the Task Manager to a couple of Mb – come fly with us...

'*FracLand* is a development version of one of my long-term projects' says Alistair. 'There are two modes, map and world, between which you toggle using Space. In map mode, the keys < and > alter the magnification, and the mouse scrolls the screen. In world mode, you fly an imaginary vehicle which goes through

mountains and handles like a helicopter that can hover but not roll or pitch past a gradient of about one in two. You use the right button to speed up and the middle button to slow down. If you press the left button you constrain the vehicle to move around in a circle, always looking at the point which was a few metres in front of you when you first pressed it. This is to let you examine bits more closely without a feat of co-ordination.

'The fractal landscape is generated every frame – with help from the last one – as it is needed. If this seems a waste of

time, that's because you don't know how big the island is. It is 16km in each direction, and is calculated to the nearest 25cm. With four bytes for colour and four bytes for height, this would take about 70 CD-ROMs to store.

'The algorithms are top-secret (but you've got the source code), and pretty obvious anyway. The trick is to get them nice and fast, and to generate a landscape that isn't just miles and miles of identical green lumps. Anyone who compares it to a game called *Comanche* (or something) on the PC which I haven't played will be politely informed that many people have done the same thing, and I suppose it's a compliment.'



*QUIT

All offerings gratefully received. Send them to:

*INFO, *Acorn User*, IDG Media,
Media House, Adlington Park,
Macclesfield SK10 4NP.

Name, address and program title on every disc please and include a text file containing same. An SAE will ensure your disc's return. Also, do please include whatever instructions, diagrams, examples and screenshots you can.

ACORN USER

ADVERTISERS INDEX

1st Computer Centre.....63	Longman Logotron.....33
4 Mation.....88	MG Research.....92
5 Star Marketing.....88	Micro Laser Design.....79
AJS Computers.....79	Oak Solutions.....26
Akalat Publishing.....81	Pineapple Software.....IBC
APDL.....88	Psycore.....58
Apricote Studios.....52	Quantum Software.....92
Armtech UK Ltd.....70	Risc User.....20
Atomwide.....OBC	Selective Computer Services.....91
Beebug.....10, 12	Senlac Computing.....81
Care Electronics.....85	Serial Port.....76
CJE Micros.....73	Serious Statistical Software.....92
Clares Micro Supplies.....18	Silicon Vision.....66
Computer Concepts.....IFC, 3, 45, 49	Skyfall.....22
CSS.....91	Skyfall Pd.....88
Cumana.....56-57	Snap Computer Supplies.....79
Daco Systems.....91	Soft Rock Software.....92
Dalriada Datatech.....92	Spacetech.....74
Datathorn Systems.....91	SSERC.....92
David Pilling.....70	Teacher Solutions.....88
Davyn Computer Services.....91	Technology Matrix.....41
Desktop Lamination.....92	Terrell Electronics.....79
Desktop Projects.....28	The Datafile.....30
Digital Psychosis.....58	The Datastore.....58
Digital Services.....15	TMJ Computer Systems.....85
Dixon & Dixon.....92	Turing Tools.....85
Fabis Computing.....103	Uniqueway.....91
I.C.S. Ltd.....6-7	Vantage One.....34-35
Irlam Instruments.....17	Watford Electronics.....94-98
ISV Products.....81	Zenta.....33

easy Font 3

The Font Management System.

With so many fonts now available for your Acorn system, why should managing them be so difficult?

The truth is, it isn't difficult at all. EasyFont does it all for you. Just drag your fonts into the EasyFont application and forget about the hassles you once had.

No more 'font not found' errors for a start!

So, if you use any application with a font menu like Impression, Artworks, Ovation 2 etc or you just fancy adding life to old fonts then call us now.

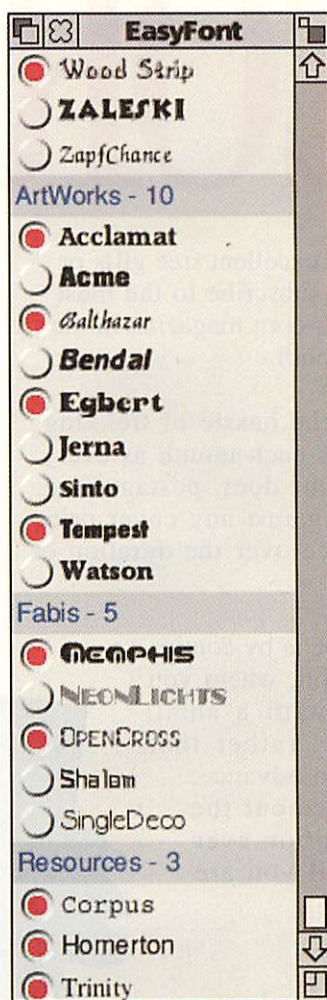

- Innovative real-time WYSIWYG font display.
- Font grouping for fast and easy reference.
- Switch your fonts on and off without restarting your applications.
- Scan files for fonts used.
- Create great new styles.
- Your font collection can take up to 40% less space on your hard disk.
- Unique font filing system
- Handles unlimited numbers of your fonts
- Easy installation.

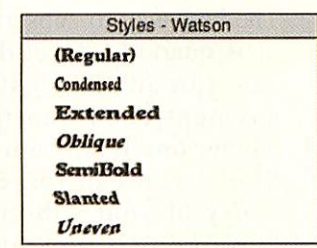

- Excellent value at just £35 (inc VAT and P&P)

CALL OUR ORDER HOTLINE NOW



01283 - 552761



EasyFont users can upgrade to version 3 by sending your original disc and £10

Fabis Computing
Sarford House
Swadlincote
Derbyshire
DE11 9SL



Email: info@fabis.demon.co.uk

Choose a FREE GIFT or exclusive special offer when you subscribe to

ACORN USER

Choose any one of these excellent free gifts or special offers when you subscribe to the most established, informative Acorn magazine in the world, each and every month.

Subscribing takes out the hassle of trekking down to the newsagents each month as every issue is delivered to your door, postage free. You're also protected against any cover price rises that may take place over the duration of your subscription.

The best way to subscribe is by continuous quarterly direct debit, where you can spread the cost with a small payment each quarter, rather than paying one lump sum in advance. Plus – you can forget about the worry of your subscription ever lapsing, as it runs until you are ready to cancel.



ONLY £5

PIPEDREAM 4

SAVE £80

Ideal for any Acorn machine with 2Mb RAM. Includes a flexible word processor, powerful spreadsheet package, charts and a fast and compact database.

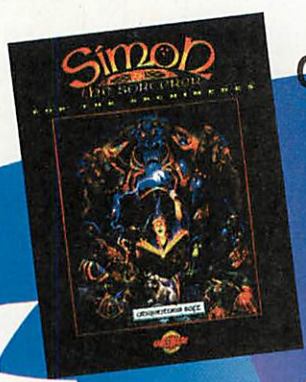

ONLY £25

SIMON THE SORCERER

SAVE £6



ONLY £5

CONJUEZ

SAVE £15

French verb conjugation software, for beginners up to GCSE standard, with over 800 verbs set in 7 levels.

FREE

CARNAGE INC *

SAVE £25





FREE

SENSIBLE SOCCER*

SAVE £20

ONLY £5

STUNT RACER 2000

SAVE £25



FREE

PANDORA'S BOX*

SAVE £25.95

FREE

ENTER THE REALM

SAVE £25.95

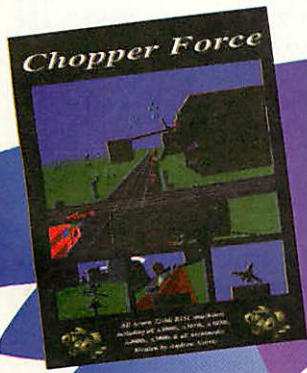

FREE

CHOPPER FORCE

SAVE £29.95

* Not suitable for the Risc PC

Subscriptions form for Acorn User

1a

Please enrol me as a subscriber to *Acorn User* for 13 issues. All subscriptions will commence with the next available issue. See section 2.

4170 UK £37.99 4171 EU £53.99 4172 World £68.99*

*Unfortunately World subscribers are not eligible to receive the free gift/special offer

I wish to pay by:

- Cheque/postal order made payable to IDG Media
 Credit card (Visa/Access/Barclaycard/Mastercard/Eurocard/Connect)

Expiry date /

Card No.

1b

Please enrol me as a subscriber to *Acorn User*.

4173 with payments of £9.49 by continuous quarterly direct debit See section 2.

Your subscription will continue until you cancel. Over a year you will receive 13 issues.

Name of Bank/Building Society

Address

Name of Account

Your Account No. Sort Code

Date Signature(s)

Your instructions to the bank/building society: I instruct you to pay direct debits from my account at the request of IDG Media. The amounts are variable and may be debited on various dates. No acknowledgement required.

any direct debit is paid which breaks the terms of the instruction, the bank/ building society will make a refund. Bank/building society may decline to accept instructions to pay direct debit from some types of accounts.

I understand that IDG Media may change the amounts and dates only after giving me prior notice. I will inform the bank/building society in writing if I wish to cancel this instruction. I understand that if

FOR OFFICE USE ONLY
 Originator's ID No. 851412
 Ref No.

2

The free gift/special offer I would like is (please tick one):

- | | | | | | |
|-------------------------------|--------------------|----------|-------------------------------|-----------------|------|
| 4162 <input type="checkbox"/> | Pipedream 4 | Only £5 | 4154 <input type="checkbox"/> | Sensible Soccer | FREE |
| 4163 <input type="checkbox"/> | Stunt Racer 2000 | Only £5 | 4156 <input type="checkbox"/> | Pandoras Box | FREE |
| 4164 <input type="checkbox"/> | Conjugez | Only £5 | 4166 <input type="checkbox"/> | Enter the Realm | FREE |
| 4165 <input type="checkbox"/> | Simon the Sorcerer | Only £25 | 4167 <input type="checkbox"/> | Chopper Force | FREE |
| | | | 4168 <input type="checkbox"/> | Carnage Inc | FREE |

♦ Please remember to either add the appropriate amount when you write your cheque or if paying by direct debit, send additional payment.

3

Name

Address

Postcode Tel.....

4

Now send your completed form and payment to Acorn User, Database Direct, FREEPOST, South Wirral L65 3EB. Tel: 0151-357 1275. Please state if credit card billing address is different from the delivery address. Photocopies or handwritten versions of the above information are acceptable.

IDG Media offers you the chance to receive information about other organisations' goods and services, please tick the box if you prefer not to take advantage of this.

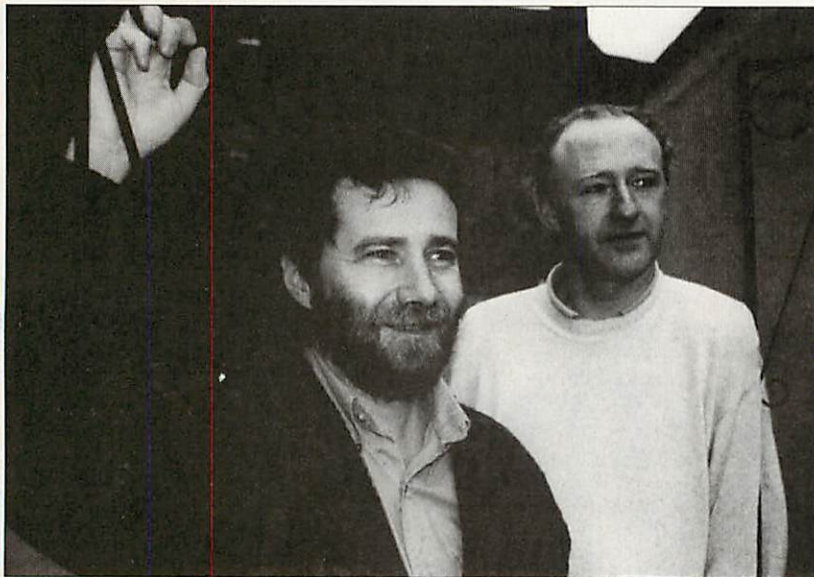

The Moxon Interview

**BILL BONHAM
AND DAVE ECCLES**

Unlike games software, our products don't get outdated: they sell constantly

There's something about living in the countryside that is totally different from living in a city, and Sherston in sunny Wiltshire is certainly in the country. As a confirmed city dweller, the thought of living somewhere where there's only one Post Office and three pubs fills me with dread, but there's something about Sherston that's special: the immense sense of community.

Nowhere is this more obvious than at Sherston Software. Walking to the pub with Bill Bonham (Managing Director) and Dave Eccles (Senior Manager) is an experience in friendly countryside manner: everyone says hello to them, smiling away. If a stranger says hello to you in London, you worry.

The reason? Sherston Software is an important part of the community. The new offices in the main street used to be a pub – The Angel House – and as anyone who watches *Emmerdale Farm* knows, pubs are the social centres of small villages. The company is also a big success story, putting Sherston on the map.

'It all started nearly 12 years ago, in the pub,' remembers Bill. The pub in question – called The Rattlebone – seems to figure highly in the history of Sherston. To start with, it's the place where Bill decided to start writing software, running Sherston Software in his spare time with two partners and his wife, Lou. Appropriately, Bill and Lou were both teachers before working for Sherston full time.

'It wasn't a hard decision to give up teaching to run the business,' says Bill. 'We've had a consistent growth, moving from premises to premises throughout Sherston. We now have 23 staff members, quite a far cry from the early days of working in the attic at home.'

One of the most important parts of the

consistent growth was the arrival of Dave Eccles in early 1991. A Geordie through and through – as is Bill, in fact – he used to be a director of the Durham Microtechnology Centre.

'Then Acorn offered me a job,' says Dave, 'and I rang Bill to see what he thought, because I'd got to know the main educational companies from the Durham job.'

'And I was having a crisis at work,' says Bill. 'We decided we needed to find a right-hand man for the business, but I was about to disappear to Australia for two months, so couldn't find one for a while.'

'I was chatting over a beer in The Rattlebone, and decided Dave would be perfect for the job. Then he rang, and mentioned he was moving: I asked him if he would be interested in working for me. After a three day interview, he got the job.'

'And it's a myth that Southerners aren't as friendly as Northerners,' says Dave. 'They're well friendly here.'

Absolutely. So now that Sherston is a well-established name in the educational field, and it's moved into beautiful new premises, what are the plans?

'We see the competition changing,' says Dave. 'Bigger players are coming into the education market, people like Microsoft. We do fine in primary schools, and our sales are increasing, but the real growth is in selling to the home market, and overseas: that's on the PC and Mac platforms.'

'Our gameplan is simple,' says Bill. 'At the moment and for the foreseeable future we develop first and mainly for the Acorn platform. As a publisher we have to look at the biggest market, so if there are products which will work and sell on other platforms, we'll convert them. It's common sense.'

'Primary schools want to stay with the Acorn platform, but there might come a stage when they move. What happens in secondary schools is normally a good indication of what will happen in primaries, and secondaries are moving over to PCs.'

'We've just got to make sure that we retain our quality and standards. As technology develops, it gets harder to create high quality products: in the last year, the size of our programming team has doubled.'

It's not surprising that the company is expanding. Over the last few years, Sherston has been producing some of the biggest-selling products in the Acorn marketplace.

'Our single biggest-selling product range has to be the *Animated Alphabet*,' says Bill. 'We've sold in excess of 22,000. Then there's *The Crystal Rain Forest* on the Archimedes, which has sold in excess of 10,000, and the Talking Software range, which has really hit a nerve.'

'*The Crystal Rain Forest* has been out for three years,' says Dave, 'and it still sells. Unlike games software, our products don't get outdated: they sell constantly.'

And it looks like Sherston titles will continue to sell constantly. Bill and Dave refer to Sherston luck: whenever they've needed something, something crops up. But it's not just down to luck, it's down to good planning and marketing, and the fact that Sherston Software is in touch with its community. Just ask anyone down The Rattlebone.

AU

The Formula 1 package for original painting and photo-retouching. Studio24 leaves the competition at the starting grid with its power and performance. The FREE updating service ensures that once you join the Pineapple team you will never have to pay for the latest model!



Studio24

This picture is original artwork produced using Studio24 by Walter Briggs of Kingfisher Graphics

A demo version of this package is available together with many example pictures and a complete copy of the manual. Price £5.00 +vat (Refundable against purchase of the full package)

Full Package Price
£125 +VAT

Graphics Tablets

The amazing pressure sensitive Wacom Tablet from EESOX. Available in A6 (Artpad), A5, A4, & A3 sizes. Cordless pen operation can completely replace all the mouse functions. Any of the above tablets can be supplied with our Studio24 painting package, which incorporates both opacity and line width control using stylus pressure, at a combined price £80.00 more than those shown below.

A6 £159.00 A5 £399.00 A4 £549.00 A3 £799.00

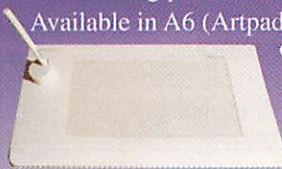

Pineapple Software Virus Protection Scheme

The Pineapple Software Virus Protection Scheme provides the most comprehensive protection available against computer viruses. !Killer together with VProtect will detect and remove all of the currently known 66 families of virus (over 100 viruses in total). Because new viruses are being discovered all the time our virus protection scheme will provide you with 3-4 updates of the software each year. We can also offer immediate advice by 'phone. !Killer can scan any filing system or device including floppies, harddiscs, networks, even CDRoms. All types of compressed file can also be scanned. All infected files are fully restored without having to reload from master discs or backups.



Don't wait until you discover you have a virus!
Use the software that Acorn themselves use to check for viruses.

A years subscription costs just £24.00 + vat
Low cost school and county licences available

Acorn Computers

We are fully authorised Acorn dealers and we can supply all Acorn computers and upgrades at very competitive prices, usually by return of post. All Acorn computers are supplied with free membership of the Virus Protection Scheme and a special offer on our Studio24 painting package of just £80.00 + vat. Please 'phone for more information and details of special computer package deals which may be available. If you are undecided as to what hardware you really need then we can provide professional advice and assistance to help you choose the right system for you.



A4 Colour Scanner

New from Pineapple the superb IX-4015 A4 flatbed Canon colour scanner. Supplied with Imaagemaster and Twain software this scanner makes the perfect companion for our Studio24 re-touching software. With a basic resolution of 400 x 800 dpi this scanner is unbeatable value.



IX4015 with Imaagemaster & Twain £599.00
As above + Studio24 £679.00
SCSI interface + cable 'phone

Colour Printers - Canon & Epson

Due to bulk purchase we can offer the BJC600 colour printer at the lowest ever prices. Also to be recommended is the Epson Stylus Colour. We also offer our Studio24 painting package when purchased at the same time as a printer at a reduced price of just £80.00 + vat.



Terms:- Please add 17.5%vat.
Carriage FREE to mainland U.K.
Phone for quote outside U.K.
Official orders, cheques and all major credit cards accepted. Money back guarantee on all products.

Pineapple Software
39, Brownlea Gardens
Seven Kings
Ilford, Essex
IG3 9NL

Telephone Hot Line service on all products
Tel 0181 599 1476 Fax 0181 598 2343

The Complete Solution

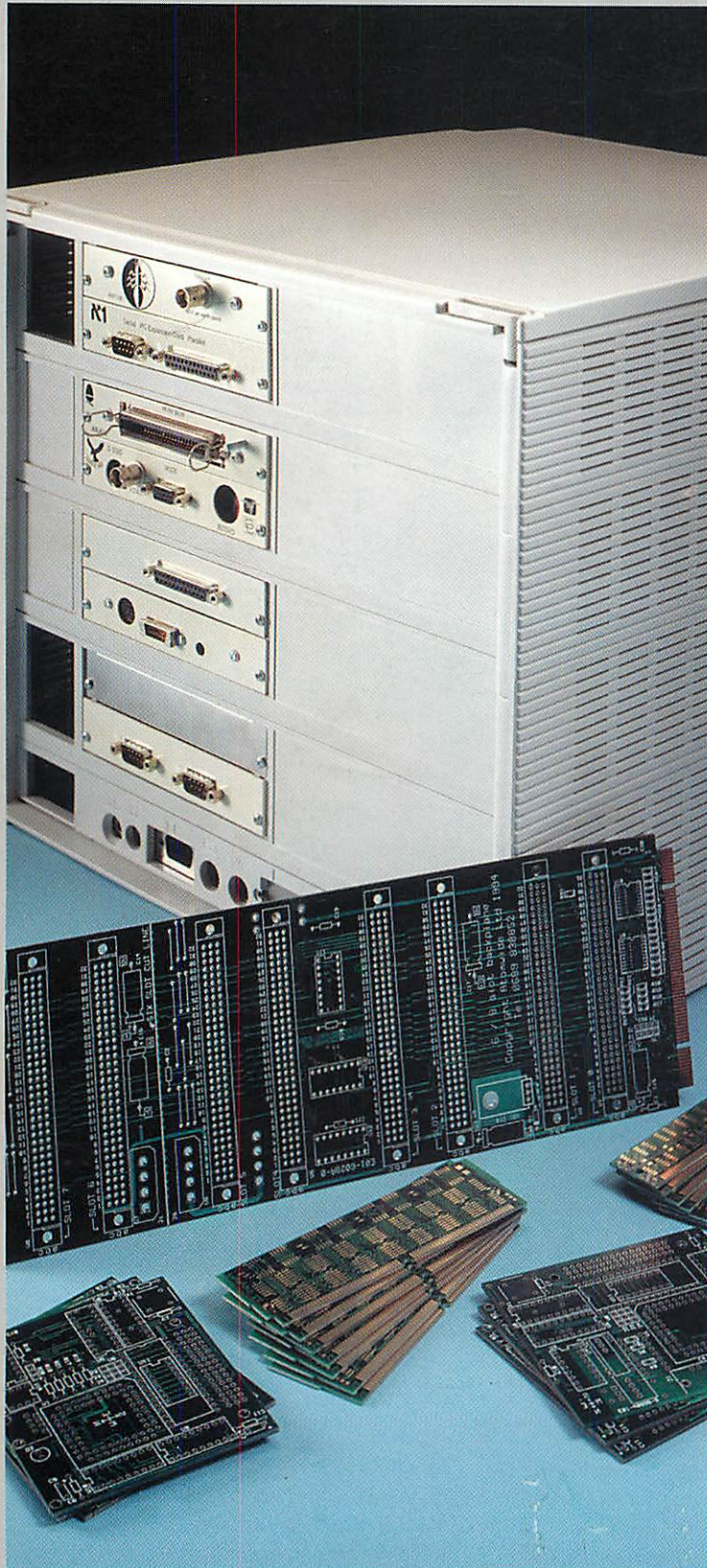

Acorn Risc PC600

If you are looking to improve the performance of your new PC600 machine or are considering replacing your existing Acorn file server with a new RiscPC machine, Atomwide can help you build a system that ideally suits your needs.

Networking

Atomwide can supply everything from one ANT Ethernet interface right up to a complete network installation. If you are planning a network installation then contact one of our staff for support and advice.

10base2	£110.00	(£129.25inc)
10baseT	£110.00	(£129.25inc)

ANT Ethernet cards are available for every type of Acorn machine, with a range of client ROMs (eg. Acorn Access).

Backplane upgrade kits

All kits come complete with a 2nd PSU, 8 slot backplane, cables, the relevant number of case slices and detailed fitting instructions.

2 slot to 8 slot	£299.00	(£351.33inc)
4 slot to 8 slot	£269.00	(£316.08inc)

Acorn Risc PC600 memory

All Atomwide memory upgrades comply with Acorn's recommended chip counts and specifications. Please phone for details of exchange prices on memory SIMMs.

SIMMs

4Mb	£120.00	(£141.00inc)
8Mb	£220.00	(£258.50inc)
16Mb	£399.00	(£468.83inc)
32Mb	£949.00	(£1115.08inc)

Larger SIMMs POA

VRAM

1Mb	£99.00	(£116.33inc)
2Mb	£160.00	(£188.00inc)
1-2Mb	£85.00	(£99.88inc)

Acorn Risc PC600 machines

Custom built and standard systems are available with and without the standard Acorn monitors. Please phone for a competitive price on your system.

All PC600s bought from Atomwide are supplied with an extra 1Mb of VRAM free.

ATOMWIDE

7, The Metro Centre, Bridge Road,
Orpington, Kent, BR5 2BE.
Tel 0689 838852 Fax 0689 896088
Email: sales@atomwide.co.uk

